



PRODUCT CATALOGUE 2018



People and technology
The evolution of air conditioning.

Galletti Group: a new approach to the market



A single partner offering diversified competences

The Galletti Group is the brainchild of a small pool of successful managers from the air conditioning industry. Today it is made up of seven different companies which have specific competences in their respective target sectors and operate in close synergism so that they can present themselves as a single partner.

Vision

To become a key partner in the various HRVAC sectors, proposing integrated package of products designed on the basis of the customers' specific requirements, maximizing efficiency and energy savings.

Mission

Design and manufacture, internally at our facilities, products with high quality standards and a high level of reliability, integrating them with high value-added pre-sales and after-sales services. Professionalism and passion are the qualities that have always distinguished our daily work.



Within the Group, it is the company which specializes in comfort applications.

It boasts over 100 years of history and today presents itself on the market as a leading manufacturer in the realm of hydronic indoor units, chillers and heat pumps for the residential and tertiary sectors.



A company that proposes solutions with a high technological content, present in the industrial and commercial air conditioning sector with a range of systems for data-processing centres and telecommunications and in the comfort sector with a range of highly customized units.



It has been operating for decades in the field of air handling and offers a wide array of AHUs and heat recuperators for civil and industrial air conditioning.



Service company specialized in energy audits. It is capable of offering complete, all-around packages in terms of services and products in the geothermal, photovoltaic and biomass sectors.



Thanks to its solid know-how in the dehumidification sector, the company is specialized in the production of dehumidifiers combinable with residential radiant systems, industrial dehumidifiers and dehumidifiers for swimming pools.



A company specialized in commercial and industrial refrigeration systems and which offers highly customized units for air conditioning and refrigeration in the transport sector.



Company providing maintenance and technical support services and after-sales support for the products of the various Group companies

Specific competences in every sector

AIR CONDITIONING

COMFORT



AUTONOMOUS RESIDENTIAL



CENTRALIZED RESIDENTIAL



SERVICE SECTOR



RAILWAY AND MARITIME

TECHNICAL



DATA CENTRE



TELECOMMUNICATION SHELTERS



CLEANROOMS

REFRIGERATION



COMMERCIAL FOR REFRIGERATED DISPLAY CASES BT
-18 | -22 °C



COMMERCIAL FOR REFRIGERATED DISPLAY CASES TN
0 | +6 °C

PROCESS



INDUSTRIAL PROCESSES COOLING



PROCESSES WITH SIMULTANEOUS OPPOSITE THERMAL LOADS



CONSULTING SERVICES:

- System integration with renewable energy sources
- Logic management for system components
- Choice of integrated solution
- Plant design assistance
- Energy audit

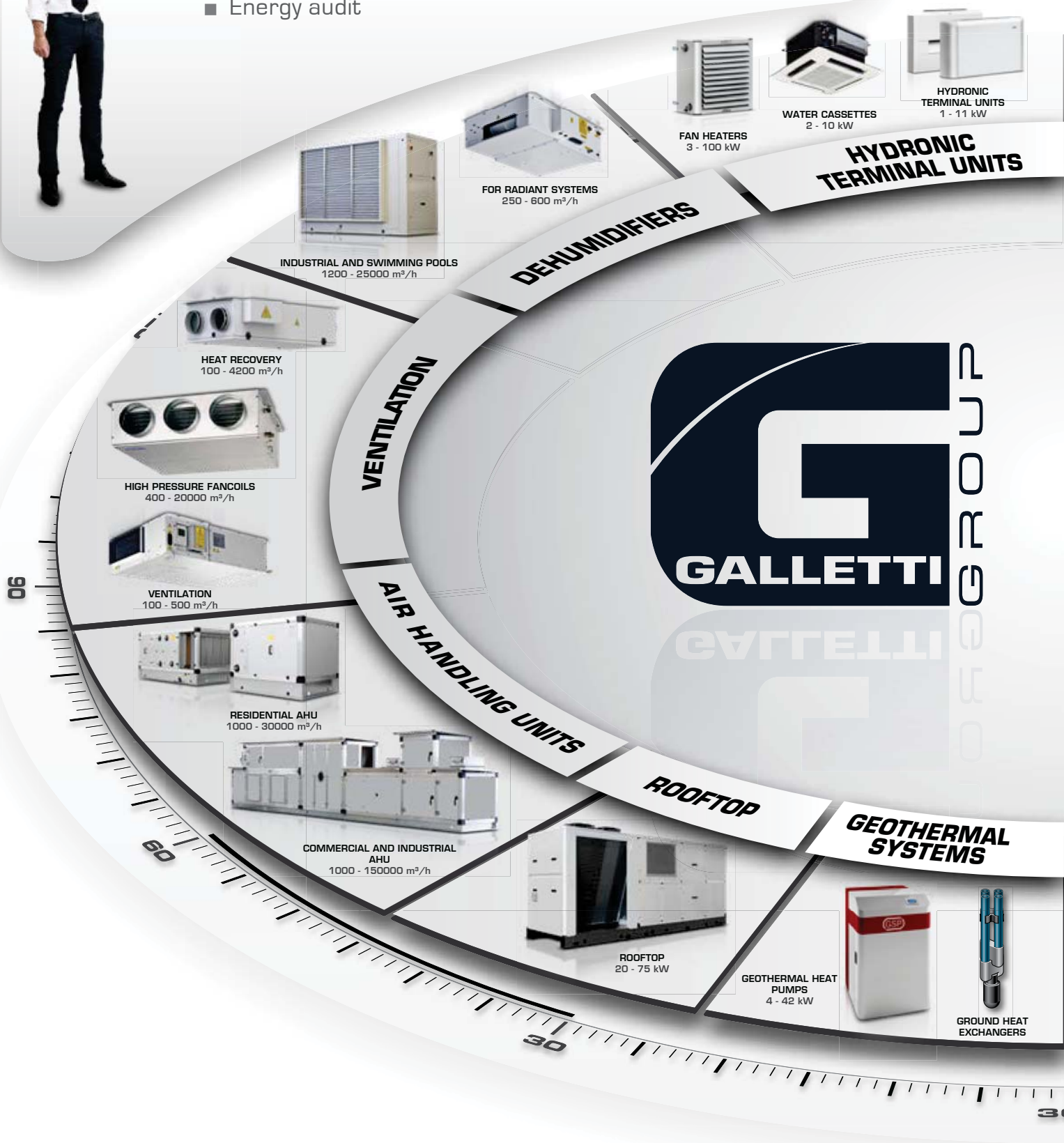

PRODUCT AND SERVICE 360°

AFTER-SALES SERVICES:

- Maintenance
- Spare part management and sales
- Remote control systems
- Plant start-up
- Diagnostics



DATA CENTER AND TELECOM AIR CONDITIONING



CRAC UNITS
3 - 240 kW



RACK COOLERS
3 - 52 kW



AIR CONDITIONERS FOR TELECOM
SHELTERS
4 - 38 kW

COMMERCIAL REFRIGERATION



MULTICOMPRESSOR PLANTS
3 - 300 kW



CONDENSING UNITS
1 - 85 kW

SOFTWARE & HARDWARE



SOFTWARE
AND HARDWARE



ELECTRONIC
CONTROLS

CHILLER AND HEAT PUMPS



AIR-WATER
4 - 1200 kW



CONDENSERLESS UNITS
40 - 480 kW



WATER-WATER
5 - 1400 kW

AIR-WATER AND WATER-WATER
MULTIPURPOSE UNITS
4 - 420 kW



FREE-COOLING
50 - 1200 kW

The evolution of air conditioning

1906

Establishment

Ugo Galletti opened a small iron works factory and workshop for repairing agricultural equipment in Castel Maggiore, a town located near Bologna.

1960

The boom years

Galletti ceased being a subcontractor and entered the heating market with its own brand.

1930

Growth

Galletti became an enterprise with more than 100 employees, working sheet metal as a subcontractor.

1970

Fresh air

A new range of products for air conditioning. After the heating sector, Galletti achieved great success in the air-conditioning market with its Polar Warm fan coil unit.



1990

Together

The Galletti Group was founded with the goal of employing specific expertise to cover all the sectors of HVACR (heating, ventilation, air conditioning and refrigeration).

2014

The Group

Today the group comprises of seven companies in the HVACR sector and eight production facilities, with a total of more than 450 employees.



2006

The centennial

The company celebrated its 100th year, and under the leadership of its CEO Luca Galletti, it confirmed its position as a leader in the market for hydronic indoor units and chillers.

Today

New goals.

For more than 30 years Galletti has been specialized in the manufacture of hydronic indoor units, chillers, and heat pumps, with specific expertise whose importance is recognized in the comfort air conditioning sector. The company's extensive experience, gained since the 1970s with more than 2,000,000 fan coil units sold, allows it to meet the new market demands while ensuring the highest level of quality and reliability. A network of qualified agencies, distributors and service centers guarantee support for the entire life of the product.

Three strategic processes

The great strength of Galletti, as well as of all the other Group companies, is that of continuing to maintain internally **the 3 strategic processes** which are the pillars of every new solution.

Research and development

The market requires products that are increasingly on the cutting edge for quality, performance, and energy efficiency. In order to satisfy this demand, Galletti has been relying for decades on a modern in-house R&D department. This department is a vital part of the company; it works in close cooperation with Production and Quality Control to guarantee a product that has been studied in the smallest detail.

The constant desire to improve the product is matched by the need to refine the research and development techniques.

The company possesses a calorimetric chamber for the hydronic indoor units and a climatic chamber for the chillers, and it is one of the few companies in Italy to possess a reverberation chamber for measuring true sound levels.



Design

That which is developed, conceived, and analyzed in the R&D Department then takes shape in the Engineering Department, which handles the mechanical and electrical design of the hydronic indoor units, chillers, and heat pumps.

The Engineering Department's dedicated team handles the development of software and hardware solutions; unlike their competitors, this activity allows the company to make proposals to the market that are open to its customers' requirements.





Vertical production

The automated sheet metal work centre is a cutting-edge production unit made up of a system which integrates an automatic magazine, a robot for bending small parts and punch and bending stations.

This latest generation system represents a clear example of what the concept of “verticalization” means for Galletti: galletti’s important expertise, together with its considerable production flexibility, are the result of not only experience, but also of the ability to internalize strategic processes such as working sheet metal.

To this must be added the management of two other important types of processing: the in-house production of heat exchangers and the in-house development of adjustment hardware and software.

The approach of developing, designing, and producing in-house semi-finished products, components, and finished products strengthens Galletti’s ability to be flexible regarding its customers’ requirements and gives Galletti a large competitive advantage over the other players in the market.

Galletti can boast a unique achievement:
a completely integrated work centre.





Software for calculating the seasonal performance of a heat pump

Recent developments in legislation promote energy efficiency and environmental sustainability in the design of equipment and installations, both in the civil and industrial realms.

In response to the new legislative constraints, Galletti, in collaboration with the University of Bologna, has developed an innovative software application called SENECA for analysing the seasonal energy performance of heat pump systems.

The average seasonal parameters (SCOP, SEER) are calculated by SENECA based on design specifications such as the local climate profile, thermo-physical performance of the building shell and whether an auxiliary generation system has been installed.

SENECA: output useful for design purposes

The SENECA calculator program simulates the operation of heat pump systems over the 12 months of the year based on project specifications. The main output calculated by SENECA are:

- » seasonal energy efficiency of the generation system, which also takes into account the possible presence of an auxiliary system (heating element, fossil fuel fired boiler)
- » seasonal consumption of the generation system, estimating the contribution deriving from a photovoltaic system serving the heat pump
- » percentage of renewable energy used by the heat pump
- » suggestion of the most efficient unit based on the design specifications
- » energy and cost comparison of heat pumps with traditional generation systems
- » determination of the optimal cut-off T for bivalent systems
- » seasonal CO₂ emissions ascribable to the generation system

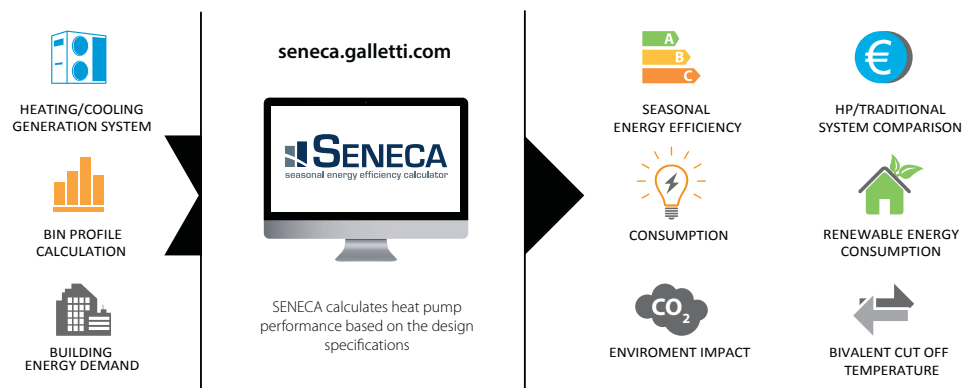



New on-line software for technical selection and configuration

Galletti has developed on its www.galletti.com web-area the new ON-LINE integrated platform for product selection, configuration and the making of the economic offer.

The software, whose use is easy and intuitive, allows the identification of the desired products by calculating their performances based on real working conditions and their configuration helping the user in choosing options and accessories. It also allows to obtain a detailed report which includes performances, dimensional drawings, tender specifications and the economic offer.



Product selection:

- » Filters to make the identification of the requested product easier
- » Performance calculation and saving of results
- » Performance comparison between products belonging to different series



Configuration and project history

- » Wizard configuration of accessories and options for chillers, heat pumps and hydronic units
- » Creation of a project which collects all products of interest
- » Complete management of the stored history projects



Report:

- » Generation of a detailed list report in pdf format
- » Choice of the sections to be included in the print:
 - Products performances
 - Dimensional drawings
 - Tender specifications



Galletti started out on the road to certification in 1994, the year in which the company entered the Eurovent program for fan coils, later followed by chillers and heat pumps.

The certification process continued up to 2000, when Galletti obtained certification of its quality system to standard UNI EN ISO 9002:1994; it subsequently obtained certification to UNI EN ISO 9001:2000.

A continuous improvement of company processes characterized the years to come, culminating in compliance with Directive 2014 / 68 / UE (PED), the upgrading of its occupational health and safety system according to OHSAS 18001:2007, and, finally in the updating to the new standard UNI EN ISO 9001:2008.

Since 2012 Galletti has been in compliance with European Regulation no. 303/2008 which makes F-GAS certification mandatory for companies that manufacture stationary refrigeration, air conditioning, and heat pump equipment containing fluorinated refrigerant gases. This certification ensures that operators are refrigeration technicians with specific expertise in protecting the environment, such as the reduction of refrigerant gases emissions into the atmosphere.





GH Service

ghservice.it

Galletti has always considered service to be of fundamental importance in order to provide an all-around range of offerings to its customers. For this reason it created GH Service as the Group's specialized service provider.

GH Service is at the customer's disposal from the design stage to the after-sales period; it operates through an extensive network of more than 200 service centres, which provide support to the numerous sales agents and distributors in Italy and around the world.

Galletti after-sales service is equipped and competent to service all types of air conditioning units, whether designed for the comfort or tertiary sectors, for processing machinery or technological environments, air handling units or highly customized units, its primary aim being customer satisfaction.

Continual interaction with all Galletti Group companies enables GH Service to be always up to date about equipment innovations, so it can guarantee its customers not only technologically advanced, high quality products but also a rapid, efficient and professional after-sales service.

The company's internal and outsourced staff are highly qualified, have long-time technical experience and are kept constantly up to date through specific refresher training courses. Its specialized technicians are in possession of all necessary certifications for operating on refrigeration cycle units and are equipped with cutting-edge tools.

GH Service is able to provide its customers various services and opportunities meeting a multitude of demands while providing highly customized services.

- » System startup
- » Trouble shooting
- » Management and sales of spare parts
- » Routine and special maintenance
- » Telephone customer support systems
- » Assembly of units at worksite
- » Disposal of obsolete units
- » Guaranteed sale of used units
- » All-inclusive rental

In a market where simply selling a product is no longer enough, Galletti, thanks to GH Service, presents itself as a single partner able to provide a comprehensive range of products and services.



Directive 2009/125/EC and 2010/30/CE

The first time horizon the European Union is setting its sights on in respect of climate and energy is 2020: it has identified new binding targets for Member States:

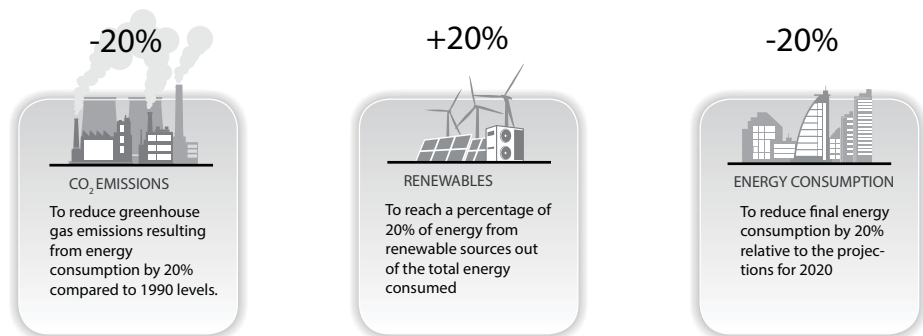

To achieve these goals, the EU has adopted the ErP directive 2009/125/CE (Energy-related Products), which regulates the eco-design requirements for all energy-using products and directive 2010/30 / EC on energy labeling. There are three main European regulations that lay down the rules for the application of Directives 2009/125/EC and 2010/30/EC:

- » 813/2013;
- » 811/2013;
- » 2281/2016.

The seasonal energy efficiency of heating space η_s is calculated as the seasonal efficiency coefficient SCOP divided by the conversion coefficient CC, corrected for the contributions in relation to the temperature controls (F1) and for the water/water heat pump units for the consumption of one or more groundwater pumps (F2).

The coefficient for conversion of electricity into primary energy was considered equal to $CC = 2.5$.

$$\eta_s = SCOP / CC - F(1) - F(2)$$

The calculation for the seasonal energy efficiency of cooling space $\eta_{s,c}$, which derives from SEER seasonal efficiency, is the same.

$$\eta_{s,c} = SEER / CC - F(1) - F(2)$$

Regulation 813/2013 applies to heat pumps with a rated capacity of less than 400 kW. For this range of capacities, minimum requirements for sound power level and seasonal energy efficiency are defined.



Directive 2009/125/EC and 2010/30/CE

The latter index must not be less than the following values:

SCOP ⁽¹⁾	Air-water	Water-water
Combined heat pumps and heat pumps	2,83	2,95
Low temperature heat pumps	3,20	3,33

Regulation 811/2013 applies to heat pumps with a heating capacity of less than 70 kW. Manufacturers are required to highlight the energy label on the unit and to specify the energy efficiency class on all technical and commercial materials.

Regulation 2281/2016 applies to chillers with cooling capacity up to 2000 kW and reversible heat pumps with cooling capacity between 400 and 2000 kW.

For this range of capacities, minimum requirements for seasonal energy efficiency are defined; in fact, since January 1, 2018, the manufacturer cannot place units on the market with SEER values less than the following values:

SEER ⁽¹⁾	Air-water	Water-water
Chiller with PC<400 kW	3,80	5,10
Chiller and reversible heat pumps with 400≤PC<1500 kW	4,10	5,88
Chiller and reversible heat pumps with 1500≤PC<2000 kW	4,10	6,33

Scope of Regulations 813/2013 and 2281/2016

	Applied regulation
Chiller with 0≤PC<2000 kW	2281/2016
Reversible heat pumps with PC<400 kW	813/2013
Reversible heat pumps with 400≤PC<2000 kW	2281/2016

The ErP directive involves and strongly influences the design of all our products Galletti, further stimulating the continuous pursuit of excellence, in terms of performance and reduction of the environmental impact.

Compliance with the regulation is not a classification of merit or an efficiency class, but rather an indispensable requirement for CE marking, without which the product cannot be placed on the EC market.

(1) Bin profile according to UNI EN 14825

TABLE OF CONTENTS

Hydronic indoor units



ESTRO
Fan coil units with centrifugal fan
1 - 11 kW **pag. 26**



ESTRO i
Fan coil units with centrifugal fan and BLDC motor
1 - 9 kW **pag. 40**



ESTRO GT
Fan coil units with BLDC GreenTech technology
1 - 6 kW **pag. 44**



ART-U
Design fan coil unit with a minimum depth of 10 cm only and BLDC motor
1 - 4 kW **pag. 48**



FLAT S
Fancoil with design cabinet, with a depth of 17 cm
1 - 3 kW **pag. 54**



FLAT S i
Fancoil with design cabinet with a depth of 17 cm, and BLDC motor
1 - 3 kW **pag. 58**



FLAT
Design fan coil units with centrifugal fan
2 - 5 kW **pag. 62**



FLAT i
Design fan coil unit with centrifugal fan and BLDC motor
2 - 5 kW **pag. 66**



FM
High wall-mounted fan coil units
2 - 4 kW **pag. 70**



2x1
Hybrid indoor units for air conditioning system
1 - 3 kW **pag. 74**



KAIMAN
Hydronic indoor unit operating with natural convection
1 - 2 kW **pag. 78**



IWC
Cassette fan coils
3 - 9 kW **pag. 80**



IWC i
Cassette fan coils with BLDC motor
3 - 10 kW **pag. 86**



DUCTIMAX
Medium-head ducted units
2 - 8 kW **pag. 90**



DUCTIMAX i
Medium available head duct units with BLDC motor
2 - 8 kW **pag. 96**

Hydronic indoor units



PWN
Medium available head duct units
3 - 10 kW

pag. 100



UTN
High-head thermal ventilating units
3 - 23 kW

pag. 110



PWN i
Medium available head duct units with BLDC motor
2 - 6 kW

pag. 106



UTN i
High-head thermal ventilating units with BLDC motor
4 - 10 kW

pag. 116

Fan heaters



AREO
Fan heaters with ON/OFF electric motor
8 - 101 kW

pag. 122



DST
Air de-stratifiers
1700 - 9100 m³/h

pag. 136



AREO i
Air conditioning fan heaters with BLDC motor
11 - 118 kW

pag. 132

Controllers and software for indoor hydronic units



TED
Simplified electronic controller

pag. 144



MYCOMFORT
Electronic microprocessor controller with LCD display

pag. 148



LED503
Recess wall-mounted control panel

pag. 145



ERGO LIGHT
Simplified monitoring system with touch screen display

pag. 150



EVO
Electronic microprocessor controller with remote user interface

pag. 146



ERGO
Supervision software for air conditioning systems

pag. 152

TABLE OF CONTENTS

Air chillers and heat pumps



MPI DC
Outdoor packaged unit with BLDC compressor
10 - 29 kW **pag. 158**



MCI
High-efficiency full inverter compact outdoor packaged units
5 - 13 kW **pag. 162**



MPE
Outdoor packaged unit
4 - 76 kW **pag. 166**



Evitech
Outdoor packaged unit
50 - 180 kW **pag. 176**



V-IPER
Outdoor packaged units
50 - 380 kW **pag. 184**



SCX
Outdoor packaged unit
80 - 360 kW **pag. 196**



LCX
Outdoor packaged unit
55 - 360 kW **pag. 210**



BCX
Outdoor packaged unit
360 - 600 kW **pag. 226**



LSE
Outdoor packaged unit
360 - 1200 kW **pag. 232**



MTE
Outdoor motor-driven condensing units
5 - 205 kW **pag. 244**



LER
Indoor motor-driven evaporating units
40 - 420 kW **pag. 252**

Water chillers and heat pumps



MCW
Indoor packaged unit
5 - 39 kW **pag. 264**



LEW
Indoor packaged unit
40 - 680 kW **pag. 270**

Total heat recovery multi-purpose units



HIWARM pag. 290
Air-water system with external and internal BLDC unit
12 - 33 kW



LCP pag. 312
Outdoor packaged air-water unit
52 - 314 kW



HIWARM COMPACT pag. 298
Outdoor packaged air-water unit with BLDC compressor
10 - 29 kW



LEP pag. 330
Indoor packaged water-water unit
50 - 470 kW



MCP pag. 302
Outdoor packaged air-water unit
7 - 41 kW

System and accessories controllers



EVO SYSTEM pag. 350
Electronic microprocessor controller for integrated system management



RYT pag. 352
Thermal storage tank for the production of domestic hot water
300 - 800 l

Heat recovery unit RPE



RPE pag. 364
Mechanical ventilation units with heat recovery
500 - 6000 m³/h





HYDRONIC INDOOR UNITS

Introduction	p. 22		
Fan coil		Thermoconvectors	
ESTRO	p. 26	KAIMAN	p. 78
ESTRO i	p. 40	Cassette units	
ESTRO GT	p. 44	IWC	p. 80
ART-U	p. 48	IWC i	p. 86
FLAT S	p. 54	Duct units	
FLAT S i	p. 58	DUCTIMAX	p. 90
FLAT	p. 62	DUCTIMAX i	p. 96
FLAT i	p. 66	PWN	p.100
FM	p. 70	PWN i	p.106
2x1	p. 74	UTN	p.110
		UTN i	p.116



Hydraulic indoor units



Vast range with over 1000 options!

It's 1961 and Galletti with its Jolly copper radiating plate enters the air conditioning world! More than half a century has gone by since then, there have been changes in the types of system and their intended use, markets and consumer demands grow and Galletti is still among the leaders in this sector.

The target is to come up with the most comprehensive range of solutions for indoor hydronic units with technologies and designs that, abreast with engineering evolution, have upgraded with the precise intention of combining reliability and innovation.

Today the offerings are completed with fan coil units with centrifugal or tangential fan, hybrid units specifically designed for residential applications, cassette units with axial-centrifugal fan, medium- and high-head ducted units and - in homage to tradition - convection heating models.



Energy savings with inverter-controlled BLDC motors

In the air conditioning sector there is by now a well-established trend toward the offering of solutions that combine performance and low energy consumption.

In line with its objective of continual innovation Galletti offers solutions with brushless motors which guarantee:

- » comfort of use thanks to the complete modulation of the air flow
- » about 50% operating costs saving compared to the conventional motors
- » the temperature setpoint in the air conditioned rooms is reached quickly
- » the power delivered is constantly adjusted according to the actual load conditions
- » exceptionally quiet operation at low speed, as in night-time mode



Design and materials

On its hydronic indoor units Galletti uses cabinets with an exclusive design, ideal for both residential and commercial settings. The quality of the materials used for their construction assures that they fully retain their characteristics over time. The plastic parts are made of UV-stabilized ABS to maintain their colour intact over time. The steel parts consist of 10/10 mm sheet with a double layer of paint, UV resistance class RUV 3 according to standard EN 10169-2.

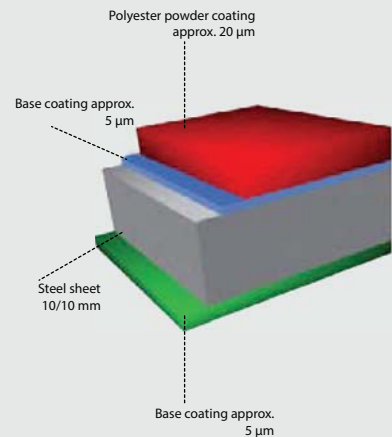

Quiet operation

The design of all the ventilation components of Galletti indoor units is developed exclusively by the company's engineering staff, backed by research and development facilities and over 50 years of specific know-how. More specifically, the most recent studies on materials and aerodynamic profiles have led to the development of special fans and scrolls conceived to ensure performances in terms of quiet operation that are among the best in Europe and Eurovent certified, combined with a correct distribution of air, which assures maximum interior comfort in any operating mode.



Efficient climate control

Galletti offers a wide range of on board or wall mounted controllers comprising more than 20 options according adjustment degree and comfort required. Design and technology are combined in the latest-generation LED or LCD controllers: EVO, LED503 e MYCOMFORT, which represent the state of the art in intelligent control of an indoor unit connected to a chiller or heat pump. Management systems, master/slave options, auto adaptive adjustment of chiller/water pump, control of room humidity are only some of the salient features of qualified and reliable offerings.

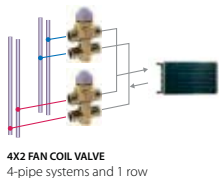
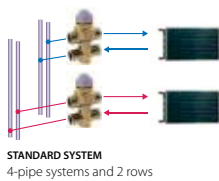

4x2 valves

Innovative concept for 4 pipe systems The 4 x 2 valves are designed for four pipe fan coil systems where "hot" and "cold" circuits are completely separated, though using the same heat exchanger mounted on the fan coil.



JONIX

JONIX Non-Thermal Plasma Generators

JONIX generators are exposed to the air flow, coming into contact with it by means of the outer electrode and the dielectric, transforming the gas into plasma.

Through the action of the electric field created by the generators, the electrons tend to accumulate on the surface of the dielectric, generating micro-discharges in the air, which in turn produce new charged particles.

The dielectric material prevents the development of discharges between the two electrodes that would damage the power supply circuit.

Non-Thermal Plasma (NTP) is considered to be the safest process for oxidizing and breaking down pollutants and for reducing of bacteria, mold, viruses, and odors. Applications in the medical field are growing, with considerable advantages over analogous systems:

- » low power consumption, minimal operating costs
- » in comparison to ozonation systems it is compatible with the presence of the operators
- » in comparison to UV systems its oxidation capacity is not affected by the crossing air flow speed
- » in comparison to systems containing electrostatic filters or photocatalytic filters, the sanitizing effect also takes place at a distance from the plasma source



Galletti's DUCTIMAX, PWN and UTN series ducted units use NTP Jonix technology to sanitize the flowing air, to carry out the microbial decontamination of the internal surfaces of the units, filters, and condensing coils, and to prevent the development of legionella in the condensate collection tanks.

The devices are sized according to their intended use, the air flow rate, and of the category of pollutants to be treated.

They are installed inside special plenums inserted on the air intake or outlet.

Indoor air quality

Air pollution in closed spaces represents a serious public health problem, with significant social and economic implications. Although the pollutants are present in concentrations that do not result in acute effects, they are the cause of negative effects on people's health and well-being, especially if connected with a long exposure period.

The international organizations WHO, Istituto Superiore della Sanità (National Institute of Health), ASHRAE, the Scientific Committee on Health and Environmental Risks (SCHER), and the European Commission in Science and Technology on Indoor Air Quality have stated that it is necessary to reduce the sources of contamination and reduce the concentrations of the pollutants included on the shared European list: Benzene, formaldehyde, carbon monoxide, nitrogen dioxide, naphthalene, volatile organic compounds, toluene, etc.

Operating principle of Non-Thermal Plasma (NTP) technology

The ionization of the air is a natural phenomenon that occurs spontaneously whenever a molecule is subject to the action of an energy process in which the total amount of energy is greater than that of the molecule itself. In practice when we add energy to a molecule, an electron is "removed" from the molecule's outermost orbit, and the resulting electric imbalance causes the molecule (atom) to assume a positive electric charge.

The electron "freed" from the outer orbit immediately attaches to another atom, which then assumes a negative electric charge. Each atom has a well-established probability of becoming a negative and positive atom depending on the saturation of its outer shell. In nature ions are produced by solar radiation; by the friction of the wind on the earth's surface; by storms, rain, and other weather events; by the absorption of cosmic rays; and by the collisions of particles possessing kinetic energy.

NTP technology artificially ionizes the air by means of what is known as "Cold Plasma".

The system is based essentially on the production of ionized gas, rich in highly "active" ionic species, which has a high chemical oxidation power, acting on:

- » proteins and unsaturated lipids of the cell membrane
- » peptidoglycans of the cell wall
- » enzymes, nucleic acids, and spores present in the cytoplasm



Functions and applications of the JONIX air sanitizing devices with NTP technology

- » Large scale retailing
- » Food processing industrial processes
- » Food preservation
- » Residential comfort
- » Service sector comfort
- Social welfare
- Hospital healthcare

Fan coil units with centrifugal fan

ESTRO 1 - 11 kW



The most complete range of fan coil units on the market featuring the Galletti technology, quality level and reliability.

The ESTRO series is undoubtedly the line of fan coil units with the most complete range of models and accessories that are able to meet the needs of professionals in the field.

The range consists of 20 models in 9 versions.

For the ESTRO project we selected top quality materials which, together with the great care and attention dedicated to the assembly of the main constructive components, make the ESTRO fan coil units highly reliable from a performance standpoint while minimising noise levels. The conception underlying the ESTRO series construction makes it possible to combine models for vertical and horizontal installation: models for surface mounting on walls, floors/ceilings and recess mounting in walls/ceilings plus low body model for floor installation.

In its recess-mounted ductable version, ESTRO has a number of accessories that permit quick and economical installation with flexible ducts directly coupled with air diffusion grilles.

ESTRO can be combined with a range of on-board or wall-mounted control panels consisting of 20 options, depending on the level of comfort and adjustment required.

An innovative air ionization system ensures the sanitization of the indoor unit and the deodorization of the ambient air.



PLUS

- » 3 - 6 speed motor
- » ABS centrifugal fans
- » Can be integrated into ERGO supervision system
- » Heat exchanger up to 4 rows
- » Reversible water connections
- » Steel cabinet / ABS
- » Incorporable ioniser



AVAILABLE VERSIONS



ESTRO FL

Version with cabinet, suitable for wall mounting. Vertical air flow, filter on the air intake securely attached to the cabinet with quarter-turn screws.

ESTRO FL is available in 20 models.



ESTRO FA

Wall mounted with cabinet. The inclined front air flow makes the ESTRO FA version especially suited for installation in recesses up to a depth of 150 mm.

ESTRO FA is available in 19 models.



ESTRO CL

Wall mounted with cabinet, vertical air flow. Designed with a range of pastel shades, it combines well with traditional furnishings and all architectures in which the warm colours and elegant shapes make ESTRO CL a perfect interior design accessory. Steel sheet panel colour: RAL 9001. ABS parts colour: PANTONE "warm gray 2 U"

ESTRO CL is available in 20 models.



ESTRO FU

Version with cabinet, suitable for floor and ceiling mounting. The cabinet has air outlet grilles and air intake grilles with built-in filter.

ESTRO FU is available in 20 models.



ESTRO FP

Version with cabinet, suitable for ceiling mounting. The air intake is located behind the air outlet grilles. This version is especially suitable if combining with external air intake louvers.

ESTRO FP is available in 20 models.



ESTRO FB

Low-cabinet version, suitable for floor and ceiling mounting. The cabinet has air outlet grilles and air intake grilles with built-in filter. Rearranging the internal components has made it possible to reduce its height to just 438 mm.

ESTRO FB is available in 9 models.



ESTRO FC

Model for vertical and horizontal recess mounting, air intake in line with the outlet, thermally insulated galvanised sheet steel body. Plenum and connectors complete the air intake and the air flow into the room.

ESTRO FC is available in 20 models.



ESTRO FF

Model for vertical and horizontal recess mounting, front air intake, thermally insulated galvanised sheet steel body. The front air intake allows horizontal or floor recessed installation with direct intake from the false-ceiling.

ESTRO FF is available in 20 models.



ESTRO FBC

Low-cabinet version for vertical and horizontal recess mounting, front air intake with air filter, thermally insulated galvanised sheet steel body. Rearranging the strategic components has made it possible to reduce its height to just 412 mm.

ESTRO FBC is available in 9 models.

MAIN COMPONENTS

Cabinet

Composed of a painted steel sheet panel, side panels, air outlet grille (swinging by 180°) and back suction grille built from ABS. Round shapes and colours that can satisfy all interior decorating needs, in line with architectural requirements.



Structure

Built from galvanised steel sheet of extra thickness, heat and sound insulated by means of Class 1 self-extinguishing panels. FU, FB, FC, FF and FBC versions have a double drip tray for collecting condensate.

Heat exchanger

High efficiency heat exchanger made with copper piping and aluminium fins, provided with brass manifolds and vent valve. The water connections are reversible at the time of installation. On request it is possible to mount an additional heat exchanger for 4-pipe systems.

Electric motor

It is mounted on vibration dampers, with permanently activated capacitor and thermal protection of the windings, and is directly coupled with the fans. It is available as either a 3- or 6-speed version in order to meet all the specific needs of performance, quietness, and power consumption.

Fans

Double suction centrifugal fans, statically and dynamically balanced, manufactured from anti-static ABS, with blades having an airfoil section and offset modules. The fans are housed in a low-noise ABS volute with high-efficiency profile.



Air filter

Honey-comb polypropylene washable air filter, easily removable for maintenance operations. On FU version the air filters are fitted onto the airinlet grille.



EVO



MYCOMFORT



LED 503



TED

ACCESSORIES

Electromechanical control panels

CB	On-board speed switch
CD	Recess wall-mounted speed switch
CDE	Wall mounted speed selector
TA	Wall-mounted room thermostat
TA2	Electromechanical room thermostat with summer/winter selection
TB	On-board speed thermostat and switch
TC	Thermostat for minimum water temperature in heating mode (42 °C)
TD	Wall mounted control with speed selector, thermostat and summer-winter selector
TD4T	Wall-mounted speed selector, thermostat and summer/winter selecting switch, for controlling fan and valves
TDC	Wall mounted control with speed selector and thermostat
TIB	On-board speed switch, thermostat and summer/winter selecting switch

Electronic microprocessor control panels with display

DIST	MY COMFORT controller spacer for wall mounting
EVODISP	User interface with display for EVO controller

KBESTE	MY COMFORT on-board installation kit for ESTRO
KL	LED503 on-board controller installation kit for ESTRO
LED503	Recessed wall-mounted electronic display controller LED 503
MCBE	MYCOMFORT BASE electronic controller with display
MCLE	Microprocessor control with display MY COMFORT LARGE
MCME	MYCOMFORT MEDIUM electronic controller with display
MCSUE	Humidity sensor for MY COMFORT (medium e large), EVO
MCSWE	Water sensor for MYCOMFORT, EVO, LED 503 controllers

Electronic microprocessor control panels

KB A	On-board ESTRO FA installation kit suitable for TED controller
KB L DX	On-board ESTRO FL/FU/FB installation kit on the right side suitable for TED controller
KB L SX	On-board ESTRO FL/FU/FB installation kit on the left side suitable for TED controller
TED 2T	Electronic controller for AC fan control and one ON/OFF 230 V valve
TED 4T	Electronic controller for AC fan control and two ON/OFF 230 V valves
TED SWA	Water temperature sensor for TED controls

ACCESSORIES

Power interface and regulating louver controllers

CSB	On-board controller for opening and closing the motor-driven regulating louver
CSD	Recess mounted controller for opening and closing the SM motor-driven regulating louver
KP	Power interface for connecting in parallel up to 4 fan coil units to the one controller

Additional heat exchanger for 4-pipe systems

DF	1-row additional heat exchanger for 4-pipe systems (not suitable for ESTRO "M" models)
-----------	--

Auxiliary water drip trays, insulating shell, condensate drainage pump

BH	Auxiliary water drip tray for horizontal installation fan coil units
BV	Auxiliary water drip tray for vertical installation fan coil units
GIVKL	Insulating shell for VKS valve, water connections on the left
GIVKR	Insulating shell for VKS valve, water connections on the right
KSC	Condensate drainage pump kit

Base and enclosure elements

D	Support elements for ESTRO FC
ZA	Pair of support covering elements with front grille for ESTRO FA
ZAG	Pair of support covering elements for ESTRO FA
ZC	Pair of support covering elements for ESTRO CL
ZCG	Pair of support covering elements for ESTRO CL
ZL	Pair of support covering elements for ESTRO FL
ZLG	Pair of support covering elements with front grille for ESTRO FL

Rear covering panels

PH	Rear painted panel for horizontal installation with cabinet
PV	Rear painted panel for vertical installation with cabinet

Electrical heating elements

RE	Heating element with installation kit, relay box and safety devices
-----------	---

Air inlet and outlet grilles

GE	Aluminium external air intake grille with subframe
GEF	Aluminium external air intake grille with subframe and air filter
GM	Aluminium air outlet grille with 2-row fins and subframe
RGC	Plenum with circular collars for air outlet grille

Plenum and connectors

RA90	Angular inlet connector
RAD	Straight inlet connector
RADC	Air inlet plenum with circular collars
RM90	Angular outlet connector
RM90C	Angular outlet insulated connector
RMCD	Straight outlet insulated connector
RMCD C	Air outlet plenum with circular collars
RMD	Straight outlet connector

External air intake louvers

S	Manual external air intake louver
SM	Motor-driven louver, with motor on the right with transformer
SM	Motor-driven louver, with motor on the left with transformer
SMC	Motor driven louver, with motor on the right, with transformer
SMC	Motor driven louver, with motor on the left, with transformer

Valves

KV	2-way valve, ON/OFF actuator, hydraulic kit on water connection side for main heat exchanger
KV24	2-way valve, ON/OFF actuator, 24 V power supply, hydraulic kit on water connection side for main heat exchanger
KV24DF	2-way valve, ON/OFF actuator, 24 V power supply, hydraulic kit on water connection side for main and additional heat exchanger
KVDF	2-way valve, ON/OFF actuator, 230 V power supply, hydraulic kit on water connection side for main and additional heat exchanger
KVM	2-way valve, MODULATING actuator, 24 V power supply, hydraulic kit on water connection side for main heat exchanger
KVMDF	2-way valve, MODULATING actuator, 24 V power supply, hydraulic kit on water connection side for main and additional heat exchanger
VKDF	3-way valve, ON/OFF actuator, 230 V power supply, complete hydraulic kit for additional heat exchanger
VKDF24	3-way valve, ON/OFF actuator, 24 V power supply, complete hydraulic kit for additional heat exchanger
VKDF24ND	3-way valve, ON/OFF actuator, 24 V power supply, hydraulic kit without holder, for additional heat exchanger
VKDFND	3-way valve, ON/OFF actuator, 230 V power supply, hydraulic kit without holder, for additional heat exchanger
VKMDF	3-way valve, MODULATING actuator, 24 V power supply, complete hydraulic kit for additional heat exchanger
VKMDFND	3-way valve, MODULATING actuator, 24 V power supply, hydraulic kit without holder, for additional heat exchanger
VKMS	3-way valve, MODULATING actuator, 14 V power supply, complete hydraulic kit for main heat exchanger
VKMSND	3-way valve, MODULATING actuator, 24 V power supply, hydraulic kit without holder, for main heat exchanger
VKS	3-way valve, ON/OFF actuator, 1230 V power supply, complete hydraulic kit for main heat exchanger
VKS24	3-way valve, ON/OFF actuator, 24 V power supply, complete hydraulic kit for main heat exchanger
VKS24ND	3-way valve, ON/OFF actuator, 24 V power supply, hydraulic kit without holder, for main heat exchanger
VKSND	3-way valve, ON/OFF actuator, 230 V power supply, hydraulic kit without holder, for main heat exchanger

RATED TECHNICAL DATA

ESTRO			1			2			3			4		
Speed			min	med	max	min	med	max	min	med	max	min	med	max
Total cooling capacity	(1)	kW	0,77	0,92	1,15	1,04	1,24	1,54	1,26	1,52	1,74	1,36	1,70	1,96
Sensible cooling capacity	(1)	kW	0,59	0,70	0,87	0,79	0,97	1,20	0,95	1,14	1,30	1,00	1,24	1,42
Total cooling capacity	(2)(E)	kW	0,75	0,90	1,12	1,02	1,21	1,50	1,24	1,48	1,69	1,34	1,66	1,91
Sensible cooling capacity	(2)(E)	kW	0,57	0,68	0,84	0,77	0,94	1,16	0,92	1,10	1,25	0,98	1,20	1,37
FCEER class	(E)		E											
Water flow	(1)	l/h	132	158	197	179	213	264	216	261	299	234	292	337
Water pressure drop	(1)(E)	kPa	4	5	7	7	9	13	8	11	14	6	9	12
Heating capacity	(3)(E)	kW	1,11	1,30	1,55	1,43	1,73	2,14	1,71	2,04	2,20	1,78	2,16	2,55
Water pressure drop	(3)(E)	kPa	3	4	6	6	8	11	7	9	12	5	8	10
Heating capacity	(4)(E)	kW	0,95	1,11	1,32	1,21	1,48	1,82	1,45	1,72	1,84	1,50	1,81	2,15
FCCOP class	(E)		E											
Water flow	(4)	l/h	166	194	229	211	256	317	252	300	320	260	315	373
Water pressure drop	(4)(E)	kPa	5	6	8	8	11	15	9	12	14	6	9	12
Rated air flow		m ³ /h	149	189	231	178	233	319	211	271	344	211	271	344
Power input	(E)	W	18	21	32	21	28	37	25	36	53	24	36	53
Total sound power level	(E)	dB(A)	30	32	40	37	42	47	38	44	49	40	44	50
Heating capacity DF 1R	(5)(E)	kW	1,18	1,31	1,49	1,31	1,49	1,66	1,36	1,56	1,76	1,36	1,56	1,76
Water flow DF 1R	(5)	l/h	103	115	130	115	130	146	120	137	154	119	136	154
Water pressure drop DF 1R	(5)(E)	kPa	2	3	4	3	4	4	4	5	7	5	5	6

ESTRO			4M			5			6			6M		
Speed			min	med	max	min	med	max	min	med	max	min	med	max
Total cooling capacity	(1)	kW	1,50	1,85	2,24	1,60	2,03	2,42	1,76	2,38	2,93	1,93	2,64	3,30
Sensible cooling capacity	(1)	kW	1,06	1,32	1,60	1,18	1,57	1,88	1,26	1,70	2,11	1,33	1,83	2,30
Total cooling capacity	(2)(E)	kW	1,48	1,81	2,19	1,57	1,99	2,36	1,73	2,34	2,87	1,90	2,60	3,24
Sensible cooling capacity	(2)(E)	kW	1,04	1,28	1,55	1,15	1,53	1,82	1,23	1,66	2,05	1,30	1,79	2,24
FCEER class	(E)		D			E			D			D		
Water flow	(1)	l/h	258	317	384	275	348	415	302	408	503	331	452	565
Water pressure drop	(1)(E)	kPa	10	14	20	8	12	16	6	9	13	7	12	17
Heating capacity	(3)(E)	kW	1,83	2,26	2,74	2,07	2,68	3,20	2,09	2,83	3,50	2,33	3,21	4,04
Water pressure drop	(3)(E)	kPa	8	11	16	6	10	13	5	8	11	6	10	14
Heating capacity	(4)(E)	kW	1,53	1,88	2,29	1,74	2,26	2,70	1,76	2,37	2,94	1,94	2,68	3,37
FCCOP class	(E)		E			E			E			D		
Water flow	(4)	l/h	265	328	397	302	393	469	301	408	506	338	466	586
Water pressure drop	(4)(E)	kPa	9	12	17	8	12	17	5	8	11	6	10	15
Rated air flow		m ³ /h	211	271	344	241	341	442	241	341	442	241	341	442
Power input	(E)	W	24	36	53	29	44	57	29	43	56	29	43	56
Total sound power level	(E)	dB(A)	41	45	51	35	43	48	36	42	48	35	43	49
Heating capacity DF 1R	(5)(E)	kW	not available			1,78	2,18	2,53	1,88	2,31	2,68	not available		
Water flow DF 1R	(5)	l/h	not available			156	191	222	165	202	234	not available		
Water pressure drop DF 1R	(5)(E)	kPa	not available			2	3	3	2	3	4	not available		

(1) Water temperature 7°C / 12°C, air temperature dry bulb 27°C, wet bulb 19°C (47% relative humidity)

(2) According to EN1397:2015

(3) Inlet water temperature 50°C, water flow rate same as in cooling mode, air temperature 20°C

(4) Water temperature 45°C / 40°C, air temperature 20°C

(5) Water temperature 65°C / 55°C, air temperature 20°C

(E) EUROVENT certified data

Power supply 230-1-50 (V-ph-Hz)

RATED TECHNICAL DATA

ESTRO			7			7M			8			8M		
Speed			min	med	max	min	med	max	min	med	max	min	med	max
Total cooling capacity	(1)	kW	1,98	2,63	3,51	2,49	3,39	4,58	2,51	3,27	4,33	2,78	3,70	4,96
Sensible cooling capacity	(1)	kW	1,45	2,04	2,75	1,73	2,37	3,22	1,80	2,45	3,15	1,94	2,59	3,50
Total cooling capacity	(2)(E)	kW	1,94	2,58	3,44	2,45	3,33	4,48	2,47	3,22	4,24	2,74	3,64	4,86
Sensible cooling capacity	(2)(E)	kW	1,41	1,99	2,69	1,69	2,31	3,12	1,76	2,40	3,06	1,90	2,53	3,40
FCEER class	(E)		E			D			D			D		
Water flow	(1)	l/h	340	451	602	426	582	785	431	561	743	477	635	850
Water pressure drop	(1)(E)	kPa	4	7	12	6	11	18	5	8	12	7	12	20
Heating capacity	(3)(E)	kW	2,81	3,69	4,78	3,01	4,08	5,49	2,98	3,90	5,10	3,36	4,45	5,95
Water pressure drop	(3)(E)	kPa	4	6	10	5	9	14	4	6	10	6	10	17
Heating capacity	(4)(E)	kW	2,39	3,13	4,05	2,51	3,40	4,57	2,47	3,24	4,24	2,80	3,70	4,95
FCCOP class	(E)		D											
Water flow	(4)	l/h	415	545	704	436	591	795	430	563	736	486	644	861
Water pressure drop	(4)(E)	kPa	5	8	13	5	9	15	4	6	13	6	10	17
Rated air flow		m ³ /h	320	450	640	320	450	640	361	497	706	361	497	706
Power input	(E)	W	40	50	65	36	61	98	40	50	90	38	61	98
Total sound power level	(E)	dB(A)	35	43	52	36	44	53	35	43	53	36	44	54
Heating capacity DF 1R	(5)(E)	kW	2,82	3,47	4,20	not available			2,73	3,22	3,82	not available		
Water flow DF 1R	(5)	l/h	247	304	368	not available			238	281	334	not available		
Water pressure drop DF 1R	(5)(E)	kPa	8	12	16	not available			8	10	14	not available		

ESTRO			9			9M			95			10		
Speed			min	med	max	min	med	max	min	med	max	min	med	max
Total cooling capacity	(1)	kW	3,00	3,66	4,51	3,52	4,37	5,40	3,42	4,19	5,26	3,97	5,27	6,71
Sensible cooling capacity	(1)	kW	2,23	2,82	3,53	2,47	3,07	3,82	2,34	3,00	3,82	2,84	3,83	4,91
Total cooling capacity	(2)(E)	kW	2,95	3,60	4,42	3,47	4,30	5,30	3,37	4,12	5,15	3,88	5,14	6,53
Sensible cooling capacity	(2)(E)	kW	2,18	2,75	3,44	2,42	3,00	3,72	2,29	2,93	3,71	2,75	3,70	4,73
FCEER class	(E)		D			D			D			E		
Water flow	(1)	l/h	515	628	774	605	750	927	587	719	902	682	905	1152
Water pressure drop	(1)(E)	kPa	7	10	14	11	16	24	9	13	19	5	8	12
Heating capacity	(3)(E)	kW	3,93	4,84	5,91	4,24	5,24	6,47	4,22	5,18	6,57	4,77	6,23	7,83
Water pressure drop	(3)(E)	kPa	6	8	12	9	13	19	7	10	16	4	6	10
Heating capacity	(4)(E)	kW	3,31	4,08	4,98	3,53	4,37	5,39	3,52	4,32	5,49	3,97	5,17	6,49
FCCOP class	(E)		D			D			D			E		
Water flow	(4)	l/h	575	709	866	613	759	937	612	752	955	690	898	1129
Water pressure drop	(4)(E)	kPa	7	10	14	10	14	20	8	12	18	4	7	10
Rated air flow		m ³ /h	470	605	785	470	605	785	488	615	814	570	771	1011
Power input	(E)	W	50	65	90	47	68	98	52	73	107	86	127	182
Total sound power level	(E)	dB(A)	43	49	56	44	50	57	44	51	58	47	54	61
Heating capacity DF 1R	(5)(E)	kW	3,55	4,07	4,64	not available			3,70	4,20	4,84	5,02	6,02	6,97
Water flow DF 1R	(5)	l/h	311	357	406	not available			324	368	423	440	527	610
Water pressure drop DF 1R	(5)(E)	kPa	5	6	8	not available			7	9	12	14	19	24

- (1) Water temperature 7°C / 12°C, air temperature dry bulb 27°C, wet bulb 19°C (47% relative humidity)
(2) According to EN1397:2015
(3) Inlet water temperature 50°C, water flow rate same as in cooling mode, air temperature 20°C
(4) Water temperature 45°C / 40°C, air temperature 20°C
(5) Water temperature 65°C / 55°C, air temperature 20°C
(E) EUROVENT certified data
Power supply 230-1-50 (V-ph-Hz)

RATED TECHNICAL DATA

ESTRO			10M			11			11M			12		
Speed			min	med	max	min	med	max	min	med	max	min	med	max
Total cooling capacity	(1)	kW	4,41	5,82	7,38	4,11	6,24	8,02	4,66	6,98	8,98	6,97	8,77	11,0
Sensible cooling capacity	(1)	kW	3,07	4,06	5,17	3,05	4,63	5,96	3,29	4,94	6,39	5,12	6,46	8,07
Total cooling capacity	(2)(E)	kW	4,32	5,69	7,20	4,00	6,07	7,78	4,55	6,81	8,74	6,76	8,53	10,6
Sensible cooling capacity	(2)(E)	kW	2,98	3,93	4,99	2,94	4,46	5,72	3,18	4,77	6,15	4,91	6,22	7,76
FCEER class	(E)		E											
Water flow	(1)	l/h	756	999	1267	706	1071	1376	800	1198	1541	1196	1505	1878
Water pressure drop	(1)(E)	kPa	8	14	21	6	13	20	9	19	29	14	22	32
Heating capacity	(3)(E)	kW	5,15	6,70	8,40	5,24	7,80	10,0	5,70	8,43	10,8	8,90	11,1	14,5
Water pressure drop	(3)(E)	kPa	7	11	17	5	11	16	8	15	24	12	18	26
Heating capacity	(4)(E)	kW	4,28	5,56	6,96	4,39	6,53	8,37	4,75	7,02	9,00	7,45	9,29	12,2
FCCOP class	(E)		E											
Water flow	(4)	l/h	743	966	1210	764	1135	1455	825	1222	1564	1295	1616	2123
Water pressure drop	(4)(E)	kPa	7	11	16	6	12	18	8	16	25	14	20	33
Rated air flow		m ³ /h	570	771	1011	642	1022	1393	642	1022	1393	1010	1317	1850
Power input	(E)	W	86	127	182	109	169	244	109	169	244	210	240	310
Total sound power level	(E)	dB(A)	48	55	62	49	60	67	50	61	68	60	64	71
Heating capacity DF 1R	(5)(E)	kW	not available			4,85	6,29	7,35	not available			6,93	8,01	9,52
Water flow DF 1R	(5)	l/h	not available			425	551	643	not available			607	701	833
Water pressure drop DF 1R	(5)(E)	kPa	not available			14	22	29	not available			24	31	42

(1) Water temperature 7°C / 12°C, air temperature dry bulb 27°C, wet bulb 19°C (47% relative humidity)

(2) According to EN1397:2015

(3) Inlet water temperature 50°C, water flow rate same as in cooling mode, air temperature 20°C

(4) Water temperature 45°C / 40°C, air temperature 20°C

(5) Water temperature 65°C / 55°C, air temperature 20°C

(E) EUROVENT certified data

Power supply 230-1-50 (V-ph-Hz)

DIMENSIONAL DRAWINGS

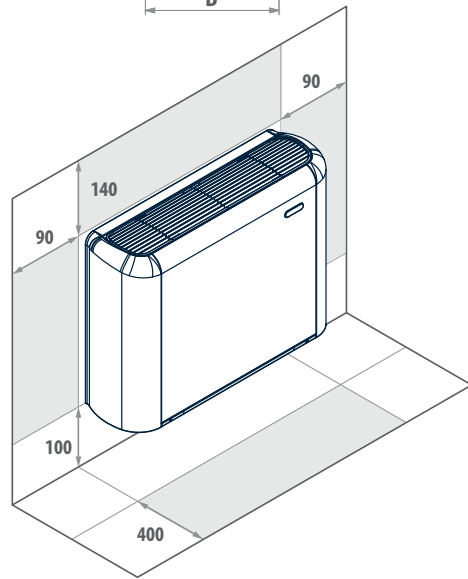
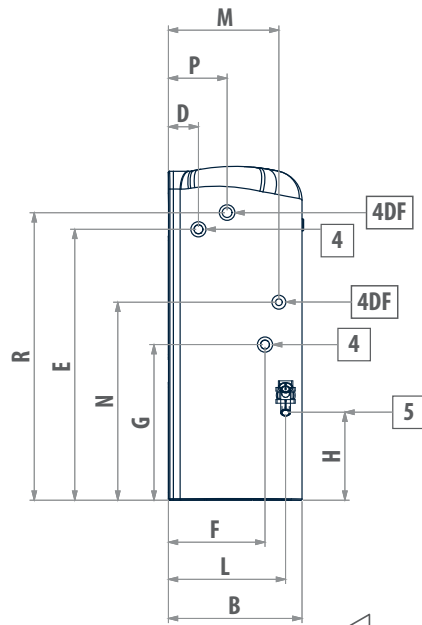
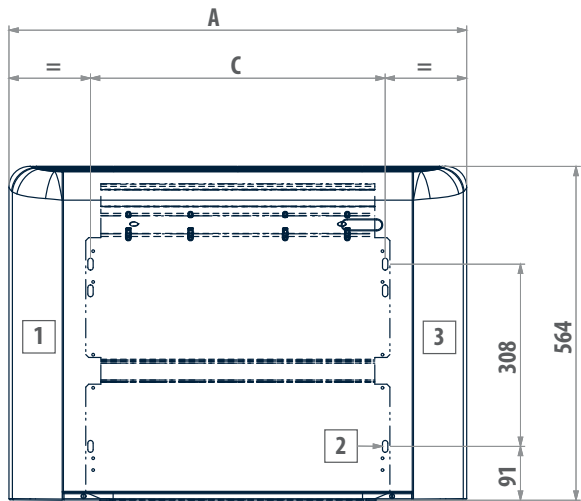
ESTRO FL - CL

LEGEND

1	Usable space for plumbing connections
2	Slots for installation on the wall
3	Usable space for electrical connections
4	Standard heat exchanger water connections
4DF	DF 1-row DF additional heat exchanger water connections
5	Condensate drainage

ESTRO	1	2	3	4	4M	5	6	6M	7	7M	8	8M	9	9M	95	10	10M	11	11M	12	
ON/OFF motor (3 speed)	x	x	x	x	x	x	x	x	x	x	x	x	x	x	x	x	x	x	x	x	x
ON/OFF motor (6 speed)	x	-	x	x	x	x	x	x	x	x	x	x	x	x	x	-	-	-	-	-	-
Inverter-controlled motor	x	-	x	x	x	x	x	x	x	-	x	-	x	x	x	-	-	x	x	-	-
GreenTech inverter-controlled motor	x	-	x	x	x	x	x	x	x	-	x	-	x	x	-	-	-	-	-	-	-

x = available

ESTRO FL	A	B	C	D	E	F	G	H	L	M	N	P	R	4	4DF	5	kg
	mm	mm	mm	mm	mm	mm	mm	mm	mm	mm	mm	mm	mm	"	"	mm	kg
1 - 2 - 3 - 4 - 4M	774	226	498	51	458	163	263	149	198	187	335	99	486	1/2	1/2	16	21
5 - 6 - 6M	984	226	708	51	458	163	263	149	198	187	335	99	486	1/2	1/2	16	27
7 - 7M - 8 - 8M - 9 - 9M	1194	226	918	51	458	163	263	149	198	187	335	99	486	1/2	1/2	16	33
95	1194	251	918	48	497	185	259	155	220	195	348	120	478	3/4	1/2	16	34
10 - 10M - 11 - 11M	1404	251	1128	48	497	185	259	155	220	195	348	120	478	3/4	1/2	16	43
12	1614	251	1338	48	497	185	259	155	220	195	348	120	478	3/4	1/2	16	53

DIMENSIONAL DRAWINGS

ESTRO FA

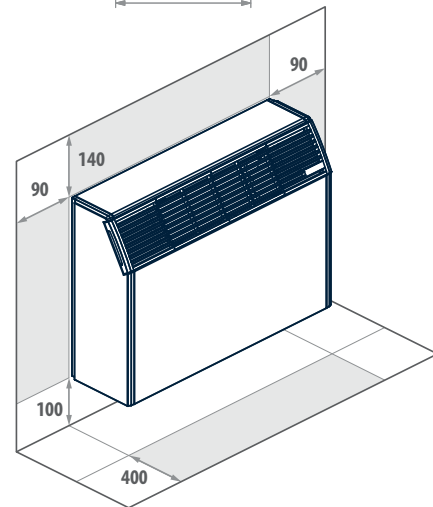
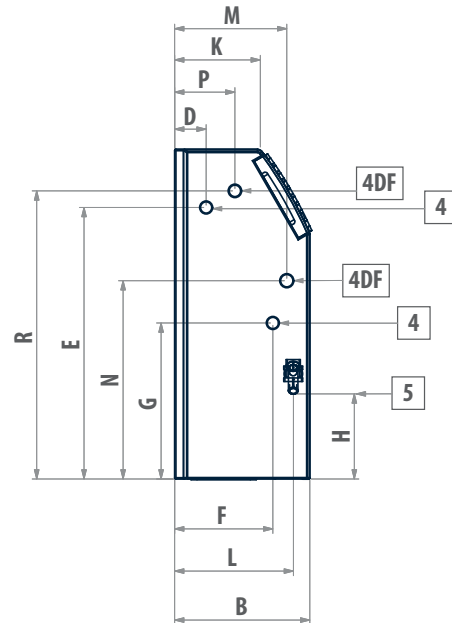
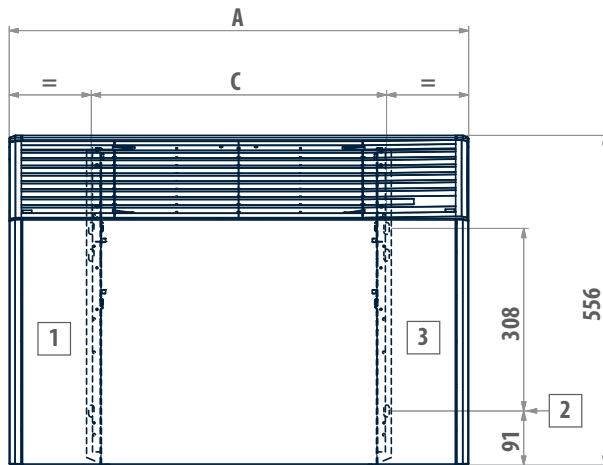

LEGEND

1	Usable space for plumbing connections
2	Slots for installation on the wall
3	Usable space for electrical connections
4	Standard heat exchanger water connections
4DF	DF 1-row DF additional heat exchanger water connections
5	Condensate drainage

ESTRO FA	1	2	3	4	4M	5	6	6M	7	7M	8	8M	9	9M	10	10M	11	11M	12	
ON/OFF motor (3 speed)	x	x	x	x	x	x	x	x	x	x	x	x	x	x	x	x	x	x	x	x
ON/OFF motor (6 speed)	x	-	x	x	x	x	x	x	x	x	x	x	x	x	-	-	-	-	-	-
Inverter-controlled motor	x	-	x	x	x	x	x	x	x	-	x	-	x	x	-	-	x	x	-	-
GreenTech inverter-controlled motor	x	-	x	x	x	x	x	x	x	-	x	-	x	x	-	-	-	-	-	-

x = available

ESTRO FA	A	B	C	D	E	F	G	H	K	L	M	N	P	R	4	4DF	5	kg
	mm	mm	mm	mm	mm	mm	mm	mm	mm	mm	mm	mm	mm	mm	"	"	mm	kg
1 - 2 - 3 - 4 - 4M	774	228	498	53	458	166	263	149	145	198	187	335	99	486	1/2	1/2	16	22
5 - 6 - 6M	984	228	708	53	458	166	263	149	145	198	187	335	99	486	1/2	1/2	16	26
7 - 7M - 8 - 8M - 9 - 9M	1194	228	918	53	458	166	263	149	145	198	187	335	99	486	1/2	1/2	16	32
10 - 10M - 11 - 11M	1404	253	1128	50	497	188	259	155	170	220	195	348	120	478	3/4	1/2	16	42
12	1614	253	1338	50	497	188	259	155	170	220	195	348	120	478	3/4	1/2	16	50

DIMENSIONAL DRAWINGS

ESTRO FU

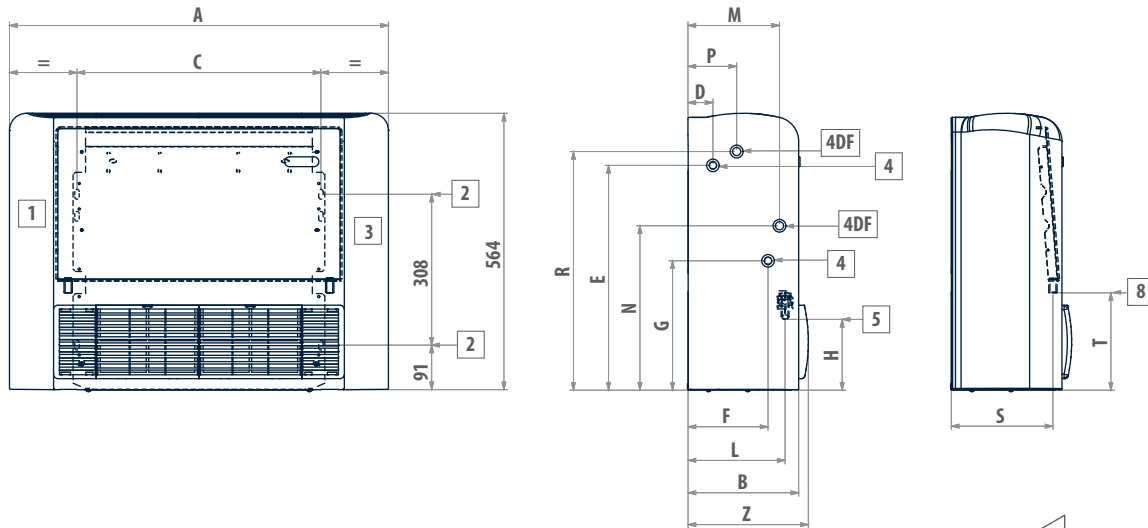

LEGEND

1	Usable space for plumbing connections
2	Slots for installation on the wall
3	Usable space for electrical connections
4	Standard heat exchanger water connections
4DF	DF 1-row DF additional heat exchanger water connections
5	Condensate drainage vertical installation
8	Condensate drainage horizontal installation

ESTRO FU	1	2	3	4	4M	5	6	6M	7	7M	8	8M	9	9M	95	10	10M	11	11M	12	
ON/OFF motor (3 speed)	x	x	x	x	x	x	x	x	x	x	x	x	x	x	x	x	x	x	x	x	x
ON/OFF motor (6 speed)	x	-	x	x	x	x	x	x	x	x	x	x	x	x	x	-	-	-	-	-	-
Inverter-controlled motor	x	-	x	x	x	x	x	x	x	-	x	-	x	x	x	-	-	x	x	-	-
GreenTech inverter-controlled motor	x	-	x	x	x	x	x	x	x	-	x	-	x	x	-	-	-	-	-	-	-

x = available

ESTRO FU	A	B	C	D	E	F	G	H	L	M	N	P	R	S	T	Z	4	kg
	mm	mm	mm	mm	mm	mm	mm	mm	mm	mm	mm	mm	mm	mm	mm	mm	"	kg
1 - 2 - 3 - 4 - 4M	774	226	498	51	458	163	263	149	198	187	335	99	486	208	198	246	1/2	22
5 - 6 - 6M	984	226	708	51	458	163	263	149	198	187	335	99	486	208	198	246	1/2	29
7 - 7M - 8 - 8M - 9 - 9M	1194	226	918	51	458	163	263	149	198	187	335	99	486	208	198	246	1/2	35
95	1194	251	918	48	497	185	259	155	220	195	348	120	478	234	208	271	3/4	36
10 - 10M - 11 - 11M	1404	251	1128	48	497	185	259	155	220	195	348	120	478	234	208	271	3/4	45
12	1614	251	1338	48	497	185	259	155	220	195	348	120	478	234	208	271	3/4	55

DIMENSIONAL DRAWINGS

ESTRO FP

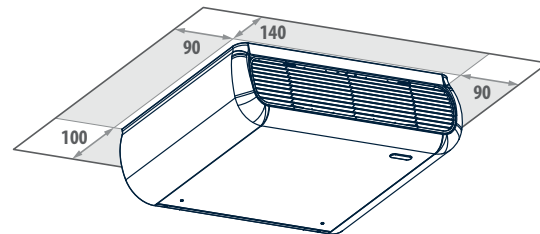
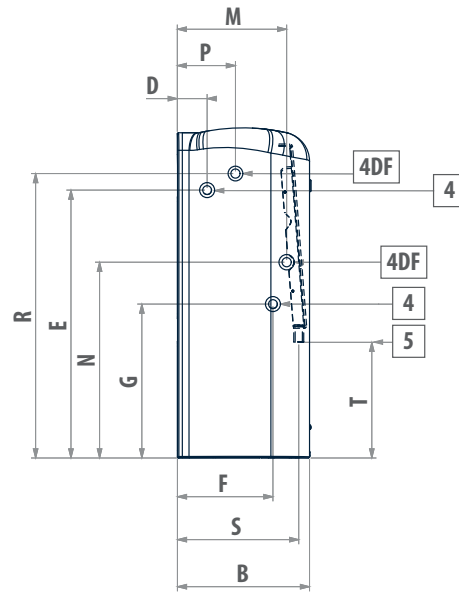
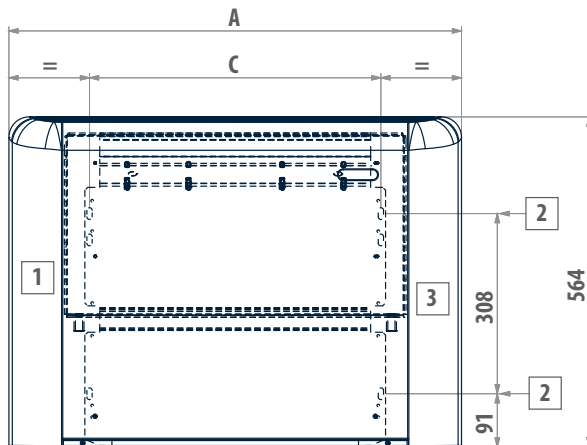

LEGEND

1	Usable space for plumbing connections
2	Slots for installation on the wall
3	Usable space for electrical connections
4	Standard heat exchanger water connections
4DF	DF 1-row DF additional heat exchanger water connections
5	Condensate drainage

ESTRO FP	1	2	3	4	4M	5	6	6M	7	7M	8	8M	9	9M	95	10	10M	11	11M	12	
ON/OFF motor (3 speed)	x	x	x	x	x	x	x	x	x	x	x	x	x	x	x	x	x	x	x	x	x
ON/OFF motor (6 speed)	x	-	x	x	x	x	x	x	x	x	x	x	x	x	x	-	-	-	-	-	-
Inverter-controlled motor	x	-	x	x	x	x	x	x	x	-	x	-	x	x	x	-	-	x	x	-	-
GreenTech inverter-controlled motor	x	-	x	x	x	x	x	x	x	-	x	-	x	x	-	-	-	-	-	-	-

x = available

ESTRO FP	A	B	C	D	E	F	G	M	N	P	R	S	T	4	4DF	5	kg
	mm	mm	mm	mm	mm	mm	mm	mm	mm	mm	mm	mm	mm	"	"	mm	kg
1 - 2 - 3 - 4 - 4M	774	226	498	51	458	163	263	187	335	99	486	208	198	1/2	1/2	16	22
5 - 6 - 6M	984	226	708	51	458	163	263	187	335	99	486	208	198	1/2	1/2	16	29
7 - 7M - 8 - 8M - 9 - 9M	1194	226	918	51	458	163	263	187	335	99	486	208	198	1/2	1/2	16	35
95	1194	251	918	48	497	185	259	195	348	120	478	234	208	3/4	1/2	16	36
10 - 10M - 11 - 11M	1404	251	1128	48	497	185	259	195	348	120	478	234	208	3/4	1/2	16	45
12	1614	251	1338	48	497	185	259	195	348	120	478	234	208	3/4	1/2	16	55

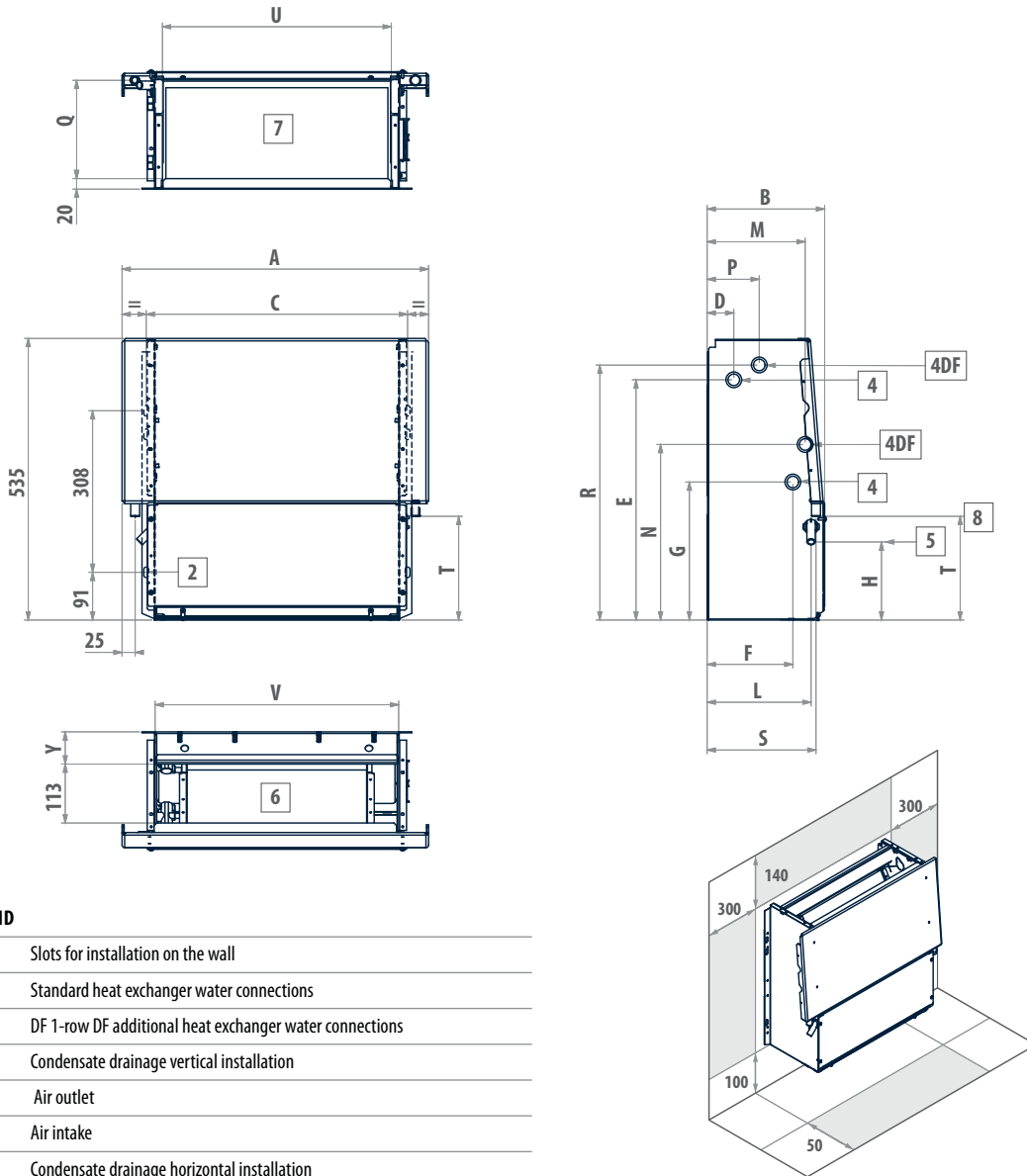
DIMENSIONAL DRAWINGS
ESTRO FC

LEGEND

2	Slots for installation on the wall
4	Standard heat exchanger water connections
4DF	DF 1-row DF additional heat exchanger water connections
5	Condensate drainage vertical installation
6	Air outlet
7	Air intake
8	Condensate drainage horizontal installation

ESTRO FC	1	2	3	4	4M	5	6	6M	7	7M	8	8M	9	9M	95	10	10M	11	11M	12	
ON/OFF motor (3 speed)	x	x	x	x	x	x	x	x	x	x	x	x	x	x	x	x	x	x	x	x	x
ON/OFF motor (6 speed)	x	-	x	x	x	x	x	x	x	x	x	x	x	x	x	-	-	-	-	-	-
Inverter-controlled motor	x	-	x	x	x	x	x	x	x	-	x	-	x	x	x	-	-	x	x	x	x
GreenTech inverter-controlled motor	x	-	x	x	x	x	x	x	x	-	x	-	x	x	-	-	-	-	-	-	x

x = available

ESTRO FC	A	B	C	D	E	F	G	H	L	M	N	P	Q	R	S	T	U	V	Y	4	kg
	mm	mm	mm	mm	mm	mm	mm	mm	mm	mm	mm	mm	mm	mm	mm	mm	mm	mm	mm	"	
1 - 2 - 3 - 4 - 4M	584	224	498	51	458	163	263	149	198	187	335	99	189	486	208	198	436	464	61	1/2	18
5 - 6 - 6M	794	224	708	51	458	163	263	149	198	187	335	99	189	486	208	198	646	674	61	1/2	23
7 - 7M - 8 - 8M - 9 - 9M	1004	224	918	51	458	163	263	149	198	187	335	99	189	486	208	198	856	884	61	1/2	27
95	1004	249	918	48	497	185	259	155	220	195	348	120	215	478	234	208	856	884	67	3/4	27
10 - 10M - 11 - 11M	1214	249	1128	48	497	185	259	155	220	195	348	120	215	478	234	208	1066	1094	67	3/4	37
12	1424	249	1338	48	497	185	259	155	220	195	348	120	215	478	234	208	1276	1304	67	3/4	43

DIMENSIONAL DRAWINGS

ESTRO FF

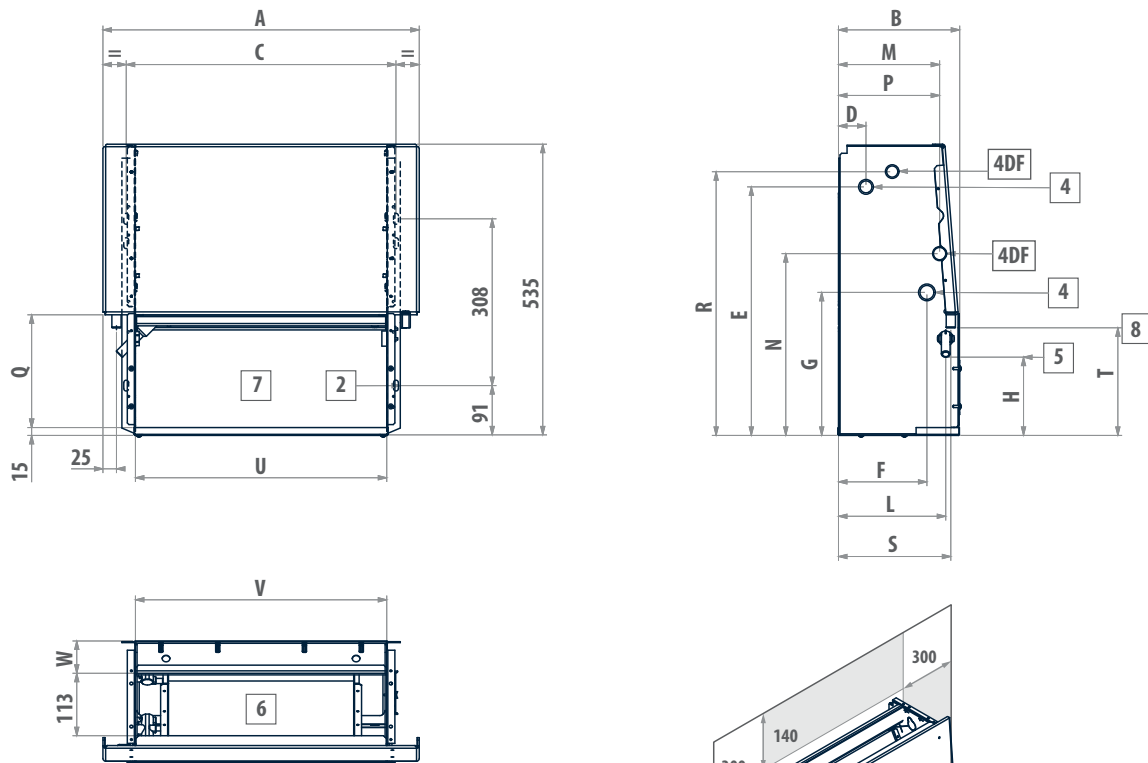

LEGEND

2	Slots for installation on the wall
4	Standard heat exchanger water connections
4DF	DF 1-row DF additional heat exchanger water connections
5	Condensate drainage vertical installation
6	Air outlet
7	Air intake
8	Condensate drainage horizontal installation

ESTRO FF	1	2	3	4	4M	5	6	6M	7	7M	8	8M	9	9M	95	10	10M	11	11M	12	
ON/OFF motor (3 speed)	x	x	x	x	x	x	x	x	x	x	x	x	x	x	x	x	x	x	x	x	x
ON/OFF motor (6 speed)	x	-	x	x	x	x	x	x	x	x	x	x	x	x	x	-	-	-	-	-	-
Inverter-controlled motor	x	-	x	x	x	x	x	x	x	-	x	-	x	x	-	-	-	-	x	x	-
GreenTech inverter-controlled motor	x	-	x	x	x	x	x	x	x	-	x	-	x	x	-	-	-	-	-	-	-

x = available

ESTRO FF	A	B	C	D	E	F	G	H	L	M	N	P	Q	R	S	T	U	V	W	4	kg
	mm	mm	mm	mm	mm	mm	mm	mm	mm	mm	mm	mm	mm	mm	mm	mm	mm	mm	mm	"	
1 - 2 - 3 - 4 - 4M	584	224	498	51	458	163	263	149	198	187	335	99	189	486	208	198	436	464	61	1/2	18
5 - 6 - 6M	794	224	708	51	458	163	263	149	198	187	335	99	189	486	208	198	646	674	61	1/2	23
7 - 7M - 8 - 8M - 9 - 9M	1004	224	918	51	458	163	263	149	198	187	335	99	189	486	208	198	856	884	61	1/2	27
95	1004	249	918	48	497	185	259	155	220	195	348	120	215	478	234	208	856	884	67	3/4	27
10 - 10M - 11 - 11M	1214	249	1128	48	497	185	259	155	220	195	348	120	215	478	234	208	1066	1094	67	3/4	37
12	1424	249	1338	48	497	185	259	155	220	195	348	120	215	478	234	208	1276	1304	67	3/4	43

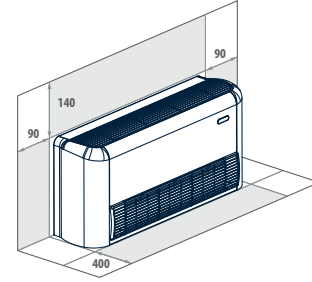
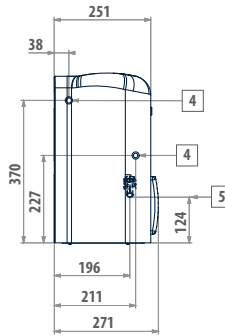
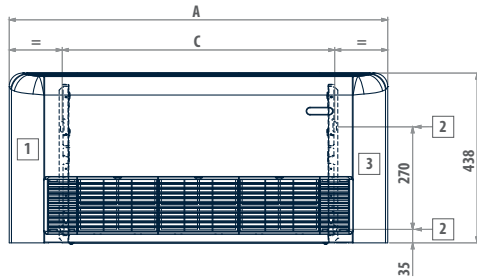
DIMENSIONAL DRAWINGS
ESTRO FB

LEGEND

- 1 Usable space for plumbing connections
- 2 Slots for installation on the wall
- 3 Usable space for electrical connections
- 4 Standard heat exchanger water connections
- 5 Condensate drainage

ESTRO FB	1	2	3	4	5	6	7	8	9
ON/OFF motor (3 speed)	x	x	x	x	x	x	x	x	x
ON/OFF motor (6 speed)	x	-	x	x	x	x	x	x	x
Inverter-controlled motor	x	-	x	x	x	x	x	x	x

x = available

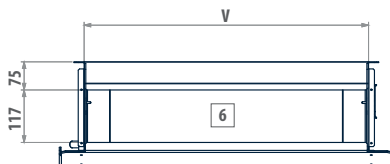
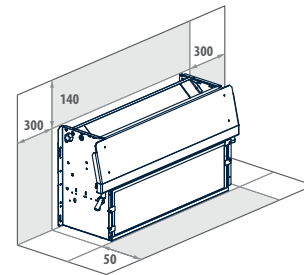
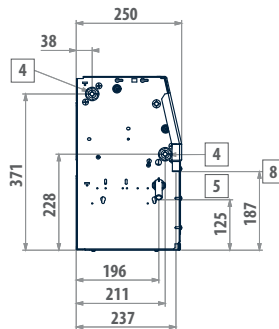
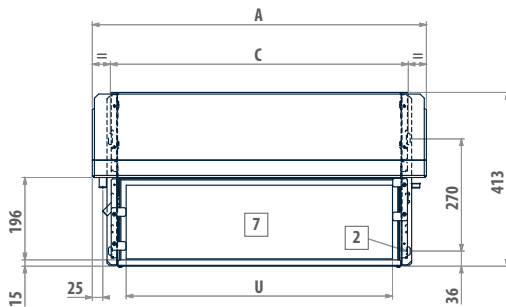
ESTRO FB	A mm	C mm	4 "	5 mm	 kg
1 - 2 - 3 - 4	774	498	1/2	16	19
5 - 6	984	708	1/2	16	28
7 - 8 - 9	1194	918	1/2	16	29

ESTRO FBC

LEGEND

- 2 Slots for installation on the wall
- 4 Standard heat exchanger water connections
- 5 Condensate drainage vertical installation
- 6 Air outlet
- 7 Air intake
- 8 Condensate drainage horizontal installation

ESTRO FBC	1	2	3	4	5	6	7	8	9
ON/OFF motor (3 speed)	x	x	x	x	x	x	x	x	x
ON/OFF motor (6 speed)	x	-	x	x	x	x	x	x	x
Inverter-controlled motor	x	-	x	x	x	x	x	x	x

x = available

ESTRO FBC	A mm	C mm	U mm	V mm	4 "	5 mm	 kg
1 - 2 - 3 - 4	584	498	423	464	1/2	16	16
5 - 6	794	708	633	674	1/2	16	20
7 - 8 - 9	1004	918	843	884	1/2	16	25

Fan coil units with centrifugal fan and BLDC motor

ESTRO i 1 - 9 kW



Energy savings and comfort in a single solution

The continual innovation that characterizes the design of ESTRO has resulted in fan assemblies with inverter-controlled permanent magnet BLDC motors.

The use of this type of motor makes it possible to achieve a major reduction in power consumption, better perceived comfort in terms of temperature and humidity. Analyses and verifications have shown a reduction in consumption of no less than 70% with integrated operation compared to traditional AC motors, with a corresponding reduction in CO₂ emissions.

The DC Inverter technology allows to continuously adjust the air flow to the actual needs of the environment by considerably reducing the fluctuations in room temperature that are typical of step-by-step adjustments. The continuous modulation of air flow brings about an adjustment in the delivered heating capacity, so that the interior is brought quickly to the set conditions and the noise levels are exceptionally low while they are being maintained.

ESTRO i fan coil units MYCOMFORT LARGE and EVO microprocessor control panels, which, thanks to the analogue outputs and refined adjustment logics, perfectly control the operation of the BLDC motors and modulating valves.

PLUS

- » Inverter-controlled BLDC motor
- » Low energy consumption
- » Modulating operation
- » Extremely quiet operation
- » Can be integrated with ERGO
- » Heat exchanger up to 4 rows
- » Incorporable ioniser



AVAILABLE VERSIONS

- ESTRO FL i** Wall mounted with cabinet
- ESTRO FA i** Wall recess mounted with cabinet
- ESTRO CL i** Wall mounted with cabinet
- ESTRO FU i** Floor and ceiling mounted with cabinet
- ESTRO FP i** Ceiling mounted with cabinet
- ESTRO FB i** Floor and ceiling mounted with low cabinet

- ESTRO FC i** Vertical / horizontal recess mounted with rear air intake
- ESTRO FF i** Vertical / horizontal recess mounted with front air intake
- ESTRO FBC i** Vertical / horizontal recess mounted with low cabinet and front air intake

MAIN COMPONENTS

Cabinet

Composed of a painted steel sheet panel, side panels, air outlet grille (swinging by 180°) and back suction grille built from ABS.

Structure

Built from galvanised steel sheet of extra thickness, heat and sound insulated by means of Class 1 self-extinguishing panels. FUi – FBi – FCI – FFi and FBCi versions are suitable for either vertical or horizontal installation thanks to the dual condensate collection and drainage system.

Heat exchanger

High efficiency heat exchanger made with copper piping and aluminium fins, provided with brass manifolds and vent valve. The water connections are reversible at the time of installation. On request it is possible to mount an additional heat exchanger for 4-pipe systems.



Fans

Double suction centrifugal fans, statically and dynamically balanced, manufactured from anti-static ABS, with blades having an airfoil section and offset modules. The fans are housed in a low-noise ABS volute with high-efficiency profile.

BLDC electric motor

Permanent magnet motor The unit is equipped with an inverter board to control the motor, that makes it possible to precisely set the maximum rotation speed of the motor (control signal 0-10 V).



Air filter

Honey-comb polypropylene washable air filter, easily removable for maintenance operations. On FUi and FBi versions the air filters are fitted onto the air inlet grille.

ACCESSORIES

Electronic microprocessor control panels with display

DIST MY COMFORT controller spacer for wall mounting

EVOBOARD Circuit board for EVO control

EVO DISP User interface with display for EVO controller

KBE MY COMFORT on-board installation kit

MCLE Microprocessor control with display MY COMFORT LARGE

MCSUE Humidity sensor for MY COMFORT (medium e large), EVO

MCSWE Water sensor for MYCOMFORT, EVO, LED 503 controllers

Electronic microprocessor control panels

KB A On-board ESTRO FA installation kit suitable for TED controller

KB L DX On-board ESTRO FL/FU/FB installation kit on the right side suitable for TED controller

KB L SX On-board ESTRO FL/FU/FB installation kit on the left side suitable for TED controller

TED 10 Electronic controller for BLDC fan equipped with inverter and ON/OFF valves 230 V

TED SWA Water temperature sensor for TED controls

Power interface and regulating louver controllers

CSB On-board controller for opening and closing the motor-driven regulating louver

CSD Recess mounted controller for opening and closing the SM motor-driven regulating louver

Additional heat exchanger for 4-pipe systems

DF 1-row additional heat exchanger for 4-pipe systems (not suitable for ESTRO "M" models)

Auxiliary water drip trays, insulating shell, condensate drainage pump

BH Auxiliary water drip tray for horizontal installation fan coil units

BV Auxiliary water drip tray for vertical installation fan coil units

GIVKL Insulating shell for VKS valve, water connections on the left

GIVKR Insulating shell for VKS valve, water connections on the right

KSC Condensate drainage pump kit

Base and enclosure elements

ZA Pair of support covering elements with front grille for ESTRO FA

ZAG Pair of support covering elements for ESTRO FA

ZC Pair of support covering elements for ESTRO CL

ZCG Pair of support covering elements for ESTRO CL

ZL Pair of support covering elements for ESTRO FL

ZLG Pair of support covering elements with front grille for ESTRO FL

Rear covering panels

PH Rear painted panel for horizontal installation with cabinet

PV Rear painted panel for vertical installation with cabinet

Air inlet and outlet grilles

GE Aluminium external air intake grille with subframe

GEF Aluminium external air intake grille with subframe and air filter

GM Aluminium air outlet grille with 2-row fins and subframe

RGC Plenum with circular collars for air outlet grille

Plenum and connectors

RA90 Angular inlet connector

RAD Straight inlet connector

RADC Air inlet plenum with circular collars

RM90 Angular outlet connector

RM90C Angular outlet insulated connector

RMCD Straight outlet insulated connector

RMCD C Air outlet plenum with circular collars

RMD Straight outlet connector

External air intake louvers

SM Motor-driven louver, with motor on the right with transformer

SM Motor-driven louver, with motor on the left with transformer

SM Motorized air intake louver

SMC Motor driven louver, with motor on the right, with transformer

SMC Motor driven louver, with motor on the left, with transformer

Valves

KV 2-way valve, ON/OFF actuator, hydraulic kit on water connection side for main heat exchanger

KVM 2-way valve, MODULATING actuator, 24 V power supply, hydraulic kit on water connection side for main heat exchanger

RATED TECHNICAL DATA

ESTRO i			1			3			4			4M		
Speed			min	med	max	min	med	max	min	med	max	min	med	max
Control voltage	(E)	V	4,00	5,30	6,50	5,20	6,90	8,40	5,20	6,90	8,40	5,20	6,90	8,40
Total cooling capacity	(1)	kW	0,77	0,92	1,15	1,26	1,52	1,74	1,36	1,70	1,96	1,50	1,85	2,24
Sensible cooling capacity	(1)	kW	0,59	0,70	0,87	0,95	1,14	1,30	1,00	1,24	1,42	1,06	1,32	1,60
Total cooling capacity	(2)(E)	kW	0,77	0,91	1,14	1,25	1,51	1,72	1,35	1,69	1,94	1,49	1,84	2,22
Sensible cooling capacity	(2)(E)	kW	0,58	0,69	0,86	0,94	1,13	1,28	0,99	1,23	1,40	1,05	1,31	1,58
FCEER class	(E)		B			B			B			A		
Water flow	(1)	l/h	132	158	197	216	261	299	234	292	337	258	317	384
Water pressure drop	(1)(E)	kPa	4	5	7	8	11	14	6	9	12	10	14	20
Heating capacity	(3)(E)	kW	1,11	1,30	1,55	1,71	2,04	2,20	1,78	2,16	2,55	1,83	2,26	2,74
Water pressure drop	(3)(E)	kPa	3	4	6	7	9	12	5	8	10	8	11	16
Heating capacity	(4)(E)	kW	0,95	1,11	1,32	1,45	1,72	1,84	1,50	1,81	2,15	1,53	1,88	2,29
FCCOP class	(E)		C			B			B			B		
Water flow	(4)	l/h	166	194	229	252	300	320	260	315	373	265	328	397
Water pressure drop	(4)(E)	kPa	5	6	8	9	12	14	6	9	12	9	12	17
Rated air flow		m ³ /h	149	189	231	211	271	344	211	271	344	211	271	344
Power input	(E)	W	6	8	9	7	9	19	7	9	19	7	9	19
Total sound power level	(E)	dB(A)	30	32	40	38	44	49	40	44	50	41	45	51
Heating capacity DF 1R	(5)(E)	kW	1,18	1,31	1,49	1,36	1,56	1,76	1,36	1,56	1,76	not available		
Water flow DF 1R	(5)	l/h	103	115	130	120	137	154	119	136	154	not available		
Water pressure drop DF 1R	(5)(E)	kPa	2	3	4	4	5	7	5	5	6	not available		

ESTRO i			5			6			6M			7		
Speed			min	med	max	min	med	max	min	med	max	min	med	max
Control voltage	(E)	V	3,80	5,70	7,30	3,80	5,70	7,30	3,80	5,70	7,30	3,60	5,40	8,00
Total cooling capacity	(1)	kW	1,60	2,03	2,42	1,76	2,38	2,93	1,93	2,64	3,30	1,98	2,63	3,51
Sensible cooling capacity	(1)	kW	1,18	1,57	1,88	1,26	1,70	2,11	1,33	1,83	2,30	1,45	2,04	2,75
Total cooling capacity	(2)(E)	kW	1,59	2,02	2,40	1,75	2,37	2,91	1,92	2,63	3,28	1,97	2,62	3,49
Sensible cooling capacity	(2)(E)	kW	1,17	1,56	1,86	1,25	1,69	2,09	1,32	1,82	2,28	1,44	2,03	2,73
FCEER class	(E)		A											
Water flow	(1)	l/h	275	348	415	302	408	503	331	452	565	340	451	602
Water pressure drop	(1)(E)	kPa	8	12	16	5	8	11	7	12	17	4	7	12
Heating capacity	(3)(E)	kW	2,07	2,68	3,20	2,09	2,83	3,50	2,33	3,21	4,04	2,81	3,69	4,78
Water pressure drop	(3)(E)	kPa	6	10	13	4	6	9	6	10	14	4	6	10
Heating capacity	(4)(E)	kW	1,74	2,26	2,70	1,76	2,37	2,94	1,94	2,68	3,37	2,39	3,13	4,05
FCCOP class	(E)		A											
Water flow	(4)	l/h	302	393	469	301	408	506	338	466	586	415	545	704
Water pressure drop	(4)(E)	kPa	8	12	17	5	8	11	6	10	15	5	8	13
Rated air flow		m ³ /h	241	341	442	241	341	442	241	341	442	320	450	640
Power input	(E)	W	6	8	16	6	8	16	6	8	16	8	12	18
Total sound power level	(E)	dB(A)	35	43	48	36	42	48	35	43	49	35	43	52
Heating capacity DF 1R	(5)(E)	kW	1,78	2,18	2,53	1,88	2,31	2,68	not available			2,82	3,47	4,20
Water flow DF 1R	(5)	l/h	156	191	222	165	202	234	not available			247	304	368
Water pressure drop DF 1R	(5)(E)	kPa	2	3	3	2	3	4	not available			8	12	16

(1) Water temperature 7°C / 12°C, air temperature dry bulb 27°C, wet bulb 19°C (47% relative humidity)

(2) According to EN1397:2015

(3) Inlet water temperature 50°C, water flow rate same as in cooling mode, air temperature 20°C

(4) Water temperature 45°C / 40°C, air temperature 20°C

(5) Water temperature 65°C / 55°C, air temperature 20°C

(E) EUROVENT certified data

Power supply 230-1-50 (V-ph-Hz)

NOTE: The dimensional drawings of the ESTRO i inverter units are the same of the ESTRO ON/OFF version. They are reported from page 33

RATED TECHNICAL DATA

ESTRO i			8			9			9M			95		
Speed			min	med	max	min	med	max	min	med	max	min	med	max
Control voltage	(E)	V	3,60	5,40	8,00	5,00	6,70	8,90	5,00	6,70	8,90	4,80	6,10	8,30
Total cooling capacity	(1)	kW	2,51	3,27	4,33	3,00	3,66	4,51	3,52	4,37	5,40	3,42	4,19	5,26
Sensible cooling capacity	(1)	kW	1,80	2,45	3,15	2,23	2,82	3,53	2,47	3,07	3,82	2,34	3,00	3,82
Total cooling capacity	(2)(E)	kW	2,50	3,26	4,30	2,99	3,64	4,48	3,51	4,35	5,37	3,41	4,17	5,22
Sensible cooling capacity	(2)(E)	kW	1,79	2,44	3,12	2,22	2,80	3,50	2,46	3,05	3,79	2,33	2,98	3,78
FCEER class	(E)		A											
Water flow	(1)	l/h	431	561	743	515	628	774	605	750	927	587	719	902
Water pressure drop	(1)(E)	kPa	5	8	12	7	10	14	11	16	24	9	13	19
Heating capacity	(3)(E)	kW	2,98	3,90	5,10	3,93	4,84	5,91	4,24	5,24	6,47	4,22	5,18	6,57
Water pressure drop	(3)(E)	kPa	4	6	10	6	8	12	9	13	19	7	10	16
Heating capacity	(4)(E)	kW	2,47	3,24	4,24	3,31	4,08	4,98	3,53	4,37	5,39	3,52	4,32	5,49
FCCOP class	(E)		A			A			B			A		
Water flow	(4)	l/h	430	563	736	575	709	866	613	759	937	612	752	955
Water pressure drop	(4)(E)	kPa	4	6	13	7	10	14	10	14	20	8	12	18
Rated air flow		m ³ /h	361	497	706	470	605	785	470	605	785	488	615	814
Power input	(E)	W	10	13	27	12	16	33	17	23	47	13	16	37
Total sound power level	(E)	dB(A)	35	43	53	43	49	56	44	50	57	44	51	58
Heating capacity DF 1R	(5)(E)	kW	2,73	3,22	3,82	3,55	4,07	4,64	not available			3,70	4,20	4,84
Water flow DF 1R	(5)	l/h	238	281	334	311	357	406	not available			324	368	423
Water pressure drop DF 1R	(5)(E)	kPa	8	10	14	5	6	8	not available			7	9	12

ESTRO i			11			11M		
Speed			min	med	max	min	med	max
Control voltage	(E)	V	3,60	6,20	8,60	3,60	6,20	8,60
Total cooling capacity	(1)	kW	4,11	6,24	8,02	4,66	6,98	8,98
Sensible cooling capacity	(1)	kW	3,05	4,63	5,96	3,29	4,94	6,39
Total cooling capacity	(2)(E)	kW	4,10	6,20	7,93	4,65	6,94	8,89
Sensible cooling capacity	(2)(E)	kW	3,04	4,59	5,87	3,28	4,90	6,30
FCEER class	(E)		A					
Water flow	(1)	l/h	706	1071	1376	800	1198	1541
Water pressure drop	(1)(E)	kPa	6	13	20	9	19	29
Heating capacity	(3)(E)	kW	5,24	7,80	10,0	5,70	8,43	10,8
Water pressure drop	(3)(E)	kPa	5	11	16	8	15	24
Heating capacity	(4)(E)	kW	4,39	6,53	8,37	4,75	7,02	9,00
FCCOP class	(E)		A					
Water flow	(4)	l/h	764	1135	1455	825	1222	1564
Water pressure drop	(4)(E)	kPa	6	12	18	8	16	25
Rated air flow		m ³ /h	642	1022	1393	642	1022	1393
Power input	(E)	W	13	38	87	13	38	87
Total sound power level	(E)	dB(A)	49	60	67	50	61	68
Heating capacity DF 1R	(5)(E)	kW	4,85	6,29	7,35	not available		
Water flow DF 1R	(5)	l/h	425	551	643	not available		
Water pressure drop DF 1R	(5)(E)	kPa	14	22	29	not available		

- (1) Water temperature 7°C / 12°C, air temperature dry bulb 27°C, wet bulb 19°C (47% relative humidity)
(2) According to EN1397:2015
(3) Inlet water temperature 50°C, water flow rate same as in cooling mode, air temperature 20°C
(4) Water temperature 45°C / 40°C, air temperature 20°C
(5) Water temperature 65°C / 55°C, air temperature 20°C
(E) EUROVENT certified data
Power supply 230-1-50 (V-ph-Hz)

NOTE: The dimensional drawings of the ESTRO i inverter units are the same of the ESTRO ON/OFF version. They are reported from page 33

Electric fan with GreenTech BLDC motor



ESTRO GT 1 - 6 kW

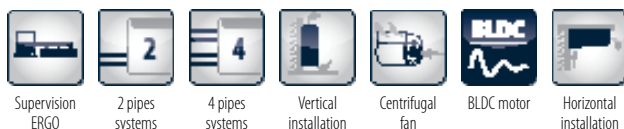

PLUS

- » GreenTech Technology
- » Inverter-controlled BLDC motor
- » Low energy consumption
- » Modulating operation
- » Extremely quiet operation
- » Can be integrated into ERGO
- » Incorporable ioniser

The maximum expression of technology at the service of the hotel industry

Galletti's extensive experience in the manufacture of fan coil units and development of refined control logics was combined with the know-how of EBM-PAPST in the construction of fan drive assemblies in order to create ESTRO GT.

The ESTRO GT design was developed specifically for the hotel industry, where fan coil units represent the most convenient solution for air conditioning rooms given that they are efficient, reliable, quiet and simple to maintain. With ESTRO GT it's almost like adding another star!

ESTRO GT uses fan drive assemblies with GreenTech technology, which means BLDC motors directly integrated with the fan assembly and inverter and 70% reductions in electricity consumption compared to traditional AC motors. The low electricity consumption is the ideal solution for installations in hotels, where the fan coil unit is running 80% of the time on average.

The extremely low noise levels and the possibility of continuous modulation of the fan speed fully satisfy guests' needs in terms of flexibility of use and quiet operation. ESTRO GT fan coil units use MYCOMFORT LARGE and EVO microprocessor control panels, which, thanks to the analogue outputs and refined adjustment logics, perfectly control the operation of the BLDC motors and modulating valves.

A wide range of accessories completes the offerings for recessed ceiling installation.

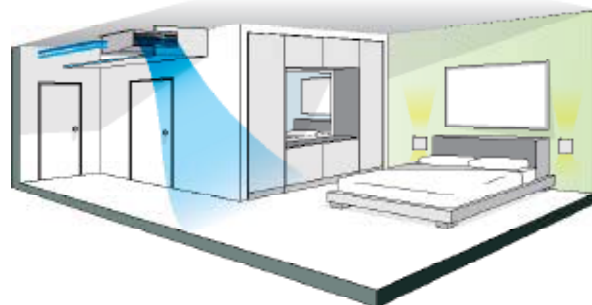

Thanks to the high efficiency and reliability guaranteed GreenTech technology, ESTRO GT reduces operating and maintenance costs while maintaining a top level of comfort and minimal noise.

AVAILABLE VERSIONS

- ESTRO FL GT** Wall mounted with cabinet
- ESTRO FA GT** Wall recess mounted with cabinet
- ESTRO CL GT** Wall mounted with cabinet
- ESTRO FU GT** Floor and ceiling mounted with cabinet

- ESTRO FP GT** Ceiling mounted with cabinet
- ESTRO FC GT** Vertical / horizontal recess mounted with rear air intake
- ESTRO FF GT** Vertical / horizontal recess mounted with front air intake

MAIN COMPONENTS

Cabinet

Composed of a painted steel sheet panel, side panels, air outlet grille (swinging by 180°) and back suction grille built from ABS.

Structure

Built from galvanised steel sheet of extra thickness, heat and sound insulated by means of Class 1 self-extinguishing panels. FU – FC – FF versions are suitable for either vertical or horizontal installation thanks to the dual condensate collection and drainage system.

Heat exchanger

High efficiency heat exchanger made with copper piping and aluminium fins, provided with brass manifolds and vent valve. The water connections are reversible at the time of installation. On request it is possible to mount an additional heat exchanger for 4-pipe systems.

Air filter

Honey-comb polypropylene washable air filter, easily removable for maintenance operations. On FU version the air filters are fitted onto the airinlet grille.

BLDC GreenTech electrical fan

ESTRO GT uses the exclusive GreenTech technology of EBM-PAPST Permanent magnet BLDC motor with inverter integrated in the fan assembly, protection rating IP44, insulation class F and ball bearings. Polypropylene (PP) volute. Centrifugal fan with forward-curved blades made of glass-filled polyamide PA 6.



ACCESSORIES

Electronic microprocessor control panels with display

DIST	MY COMFORT controller spacer for wall mounting
EVOBOARD	Circuit board for EVO control
EVO DISP	User interface with display for EVO controller
KBESTE	MY COMFORT on-board installation kit for ESTRO
MCLE	Microprocessor control with display MY COMFORT LARGE
MCSUE	Humidity sensor for MY COMFORT (medium e large), EVO
MCSWE	Water sensor for MYCOMFORT, EVO, LED 503 controllers

Electronic microprocessor control panels

KB A	On-board ESTRO FA installation kit suitable for TED controller
KB L DX	On-board ESTRO FL/FU/FB installation kit on the right side suitable for TED controller
KB L SX	On-board ESTRO FL/FU/FB installation kit on the left side suitable for TED controller
TED 10	Electronic controller for BLDC fan equipped with inverter and ON/OFF valves 230 V
TED SWA	Water temperature sensor for TED controls

Power interface and regulating louver controllers

CSB	On-board controller for opening and closing the motor-driven regulating louver
CSD	Recess mounted controller for opening and closing the SM motor-driven regulating louver

Additional heat exchanger for 4-pipe systems

DF	1-row additional heat exchanger for 4-pipe systems (not suitable for ESTRO "M" models)
-----------	--

Auxiliary water drip trays, insulating shell, condensate drainage pump

BH	Auxiliary water drip tray for horizontal installation fan coil units
BV	Auxiliary water drip tray for vertical installation fan coil units
GIVK	Insulating shell for VKS valve
KSC	Condensate drainage pump kit

Base and enclosure elements

D	Support elements for ESTRO FC
ZA	Pair of support covering elements with front grille for ESTRO FA
ZAG	Pair of support covering elements for ESTRO FA
ZC	Pair of support covering elements for ESTRO CL
ZCG	Pair of support covering elements for ESTRO CL
ZL	Pair of support covering elements for ESTRO FL
ZLG	Pair of support covering elements with front grille for ESTRO FL

Rear covering panels

PH	Rear painted panel for horizontal installation with cabinet
PV	Rear painted panel for vertical installation with cabinet

Electrical heating elements

RE	Heating element with installation kit, relay box and safety devices
-----------	---

Air inlet and outlet grilles

GE	Aluminium external air intake grille with subframe
GEF	Aluminium external air intake grille with subframe and air filter
GM	Aluminium air outlet grille with 2-row fins and subframe
RGC	Plenum with circular collars for air outlet grille

Plenum and connectors

RA90	Angular inlet connector
RAD	Straight inlet connector

RADC	Air inlet plenum with circular collars
-------------	--

RM90	Angular outlet connector
RM90C	Angular outlet insulated connector
RMCD	Straight outlet insulated connector
RMCD C	Air outlet plenum with circular collars
RMD	Straight outlet connector

External air intake louvers

SM	Motor-driven louver, with motor on the right with transformer
SM	Motor-driven louver, with motor on the left with transformer
SM	Motorized air intake louver
SMC	Motor driven louver, with motor on the right, with transformer
SMC	Motor driven louver, with motor on the left, with transformer

Valves

KV	2-way valve, ON/OFF actuator, hydraulic kit on water connection side for main heat exchanger
KV24	2-way valve, ON/OFF actuator, 24 V power supply, hydraulic kit on water connection side for main heat exchanger
KV24DF	2-way valve, ON/OFF actuator, 24 V power supply, hydraulic kit on water connection side for main and additional heat exchanger
KVDF	2-way valve, ON/OFF actuator, 230 V power supply, hydraulic kit on water connection side for main and additional heat exchanger
KVM	2-way valve, MODULATING actuator, 24 V power supply, hydraulic kit on water connection side for main heat exchanger
KVMDF	2-way valve, MODULATING actuator, 24 V power supply, hydraulic kit on water connection side for main and additional heat exchanger
VKDF	3-way valve, ON/OFF actuator, 230 V power supply, complete hydraulic kit for additional heat exchanger
VKDF24	3-way valve, ON/OFF actuator, 24 V power supply, complete hydraulic kit for additional heat exchanger
VKDF24ND	3-way valve, ON/OFF actuator, 24 V power supply, hydraulic kit without holder, for additional heat exchanger
VKDFND	3-way valve, ON/OFF actuator, 230 V power supply, hydraulic kit without holder, for additional heat exchanger
VKMDf	3-way valve, MODULATING actuator, 24 V power supply, complete hydraulic kit for additional heat exchanger
VKMDfND	3-way valve, MODULATING actuator, 24 V power supply, hydraulic kit without holder, for additional heat exchanger
VKMS	3-way valve, MODULATING actuator, 14 V power supply, complete hydraulic kit for main heat exchanger
VKMSND	3-way valve, MODULATING actuator, 24 V power supply, hydraulic kit without holder, for main heat exchanger
VKS	3-way valve, ON/OFF actuator, 1230 V power supply, complete hydraulic kit for main heat exchanger
VKS24	3-way valve, ON/OFF actuator, 24 V power supply, complete hydraulic kit for main heat exchanger
VKS24ND	3-way valve, ON/OFF actuator, 24 V power supply, hydraulic kit without holder, for main heat exchanger
VKSND	3-way valve, ON/OFF actuator, 230 V power supply, hydraulic kit without holder, for main heat exchanger

RATED TECHNICAL DATA

ESTRO GT			1			3			4			4M		
Speed			min	med	max	min	med	max	min	med	max	min	med	max
Control voltage	(E)	V	2,10	2,50	3,00	2,80	3,70	5,10	2,80	3,70	5,10	2,80	3,70	5,10
Total cooling capacity	(1)	kW	0,77	0,92	1,15	1,26	1,52	1,74	1,36	1,70	1,96	1,50	1,85	2,24
Sensible cooling capacity	(1)	kW	0,59	0,70	0,87	0,95	1,14	1,30	1,00	1,24	1,42	1,06	1,32	1,60
Total cooling capacity	(2)(E)	kW	0,77	0,91	1,14	1,25	1,51	1,72	1,35	1,69	1,94	1,49	1,84	2,22
Sensible cooling capacity	(2)(E)	kW	0,59	0,69	0,86	0,94	1,13	1,28	0,99	1,23	1,40	1,05	1,31	1,58
FCEER class	(E)		B			B			B			A		
Water flow	(1)	l/h	132	158	197	216	261	299	234	292	337	258	317	384
Water pressure drop	(1)(E)	kPa	4	5	7	8	11	14	6	9	12	10	14	20
Heating capacity	(3)(E)	kW	1,11	1,30	1,55	1,71	2,04	2,20	1,78	2,16	2,55	1,83	2,26	2,74
Water pressure drop	(3)(E)	kPa	3	4	6	7	9	12	5	8	10	8	11	16
Heating capacity	(4)(E)	kW	0,95	1,11	1,32	1,45	1,72	1,84	1,50	1,81	2,15	1,53	1,88	2,29
FCCOP class	(E)		B											
Water flow	(4)	l/h	166	194	229	252	300	320	260	315	373	265	328	397
Water pressure drop	(4)(E)	kPa	5	6	8	9	12	14	6	9	12	9	12	17
Rated air flow		m ³ /h	149	189	231	211	271	344	211	271	344	211	271	344
Power input	(E)	W	5	6	8	7	10	16	7	10	16	7	10	16
Total sound power level	(E)	dB(A)	30	32	40	38	44	49	40	44	50	41	45	51
Heating capacity DF 1R	(5)(E)	kW	1,18	1,31	1,49	1,36	1,56	1,76	1,36	1,56	1,76	not available		
Water flow DF 1R	(5)	l/h	103	115	130	120	137	154	119	136	154	not available		
Water pressure drop DF 1R	(5)(E)	kPa	2	3	4	4	5	7	5	5	6	not available		

ESTRO GT			5			6			6M			7		
Speed			min	med	max	min	med	max	min	med	max	min	med	max
Control voltage	(E)	V	2,50	3,90	5,40	2,50	3,90	5,40	2,50	3,90	5,40	2,50	3,60	5,70
Total cooling capacity	(1)	kW	1,60	2,03	2,42	1,76	2,38	2,93	1,93	2,64	3,30	1,98	2,63	3,51
Sensible cooling capacity	(1)	kW	1,18	1,57	1,88	1,26	1,70	2,11	1,33	1,83	2,30	1,45	2,04	2,75
Total cooling capacity	(2)(E)	kW	1,59	2,02	2,41	1,75	2,37	2,91	1,92	2,63	3,29	1,97	2,62	3,49
Sensible cooling capacity	(2)(E)	kW	1,17	1,56	1,87	1,25	1,69	2,09	1,32	1,82	2,29	1,44	2,03	2,73
FCEER class	(E)		A											
Water flow	(1)	l/h	275	348	415	302	408	503	331	452	565	340	451	602
Water pressure drop	(1)(E)	kPa	8	12	16	5	8	11	7	12	17	4	7	12
Heating capacity	(3)(E)	kW	2,07	2,68	3,20	2,09	2,83	3,50	2,33	3,21	4,04	2,81	3,69	4,78
Water pressure drop	(3)(E)	kPa	6	10	13	4	6	9	6	10	14	4	6	10
Heating capacity	(4)(E)	kW	1,74	2,26	2,70	1,76	2,37	2,94	1,94	2,68	3,37	2,39	3,13	4,05
FCCOP class	(E)		A											
Water flow	(4)	l/h	302	393	469	301	408	506	338	466	586	415	545	704
Water pressure drop	(4)(E)	kPa	8	12	17	5	8	11	6	10	15	5	8	13
Rated air flow		m ³ /h	241	341	442	241	341	442	241	341	442	320	450	640
Power input	(E)	W	5	9	14	5	9	16	5	9	14	6	9	19
Total sound power level	(E)	dB(A)	35	43	48	36	42	48	35	43	49	35	43	52
Heating capacity DF 1R	(5)(E)	kW	1,78	2,18	2,53	1,88	2,31	2,68	not available			2,82	3,47	4,20
Water flow DF 1R	(5)	l/h	156	191	222	165	202	234	not available			247	304	368
Water pressure drop DF 1R	(5)(E)	kPa	2	3	3	2	3	4	not available			8	12	16

- (1) Water temperature 7°C / 12°C, air temperature dry bulb 27°C, wet bulb 19°C (47% relative humidity)
 (2) According to EN1397:2015
 (3) Inlet water temperature 50°C, water flow rate same as in cooling mode, air temperature 20°C
 (4) Water temperature 45°C / 40°C, air temperature 20°C
 (5) Water temperature 65°C / 55°C, air temperature 20°C
 (E) EUROVENT certified data

NOTE: The dimensional drawings of the ESTRO GT equipped units are the same of the ESTRO ON/OFF version. They are reported from page 33

RATED TECHNICAL DATA

ESTRO GT			8			9			9M		
Speed			min	med	max	min	med	max	min	med	max
Control voltage	(E)	V	2,80	4,10	6,50	3,80	5,30	7,60	3,80	5,30	7,60
Total cooling capacity	(1)	kW	2,51	3,27	4,33	3,00	3,66	4,51	3,52	4,37	5,40
Sensible cooling capacity	(1)	kW	1,80	2,45	3,15	2,23	2,82	3,53	2,47	3,07	3,82
Total cooling capacity	(2)(E)	kW	2,50	3,26	4,31	2,99	3,64	4,48	3,51	4,35	5,37
Sensible cooling capacity	(2)(E)	kW	1,79	2,44	3,13	2,22	2,80	3,50	2,46	3,05	3,79
FCEER class	(E)		A								
Water flow	(1)	l/h	431	561	743	515	628	774	605	750	927
Water pressure drop	(1)(E)	kPa	5	8	12	7	10	14	11	16	24
Heating capacity	(3)(E)	kW	2,98	3,90	5,10	3,93	4,84	5,91	4,24	5,24	6,47
Water pressure drop	(3)(E)	kPa	4	6	10	6	8	12	9	13	19
Heating capacity	(4)(E)	kW	2,47	3,24	4,24	3,31	4,08	4,98	3,53	4,37	5,39
FCCOP class	(E)		A								
Water flow	(4)	l/h	430	563	736	575	709	866	613	759	937
Water pressure drop	(4)(E)	kPa	4	6	13	7	10	14	10	14	20
Rated air flow		m ³ /h	361	497	706	470	605	785	470	605	785
Power input	(E)	W	7	11	24	10	17	32	10	17	32
Total sound power level	(E)	dB(A)	35	43	53	43	49	56	44	50	57
Heating capacity DF 1R	(5)(E)	kW	2,73	3,22	3,82	3,55	4,07	4,64	not available		
Water flow DF 1R	(5)	l/h	238	281	334	311	357	406	not available		
Water pressure drop DF 1R	(5)(E)	kPa	8	10	14	5	6	8	not available		

- (1) Water temperature 7°C / 12°C, air temperature dry bulb 27°C, wet bulb 19°C (47% relative humidity)
 (2) According to EN1397:2015
 (3) Inlet water temperature 50°C, water flow rate same as in cooling mode, air temperature 20°C
 (4) Water temperature 45°C / 40°C, air temperature 20°C
 (5) Water temperature 65°C / 55°C, air temperature 20°C
 (E) EUROVENT certified data

NOTE: The dimensional drawings of the ESTRO GT equipped units are the same of the ESTRO ON/OFF version. They are reported from page 33

Design fan coil unit with a minimum depth of 10 cm only and BLDC motor

ART-U 1 - 4 kW

Available from SEPTEMBER 2018



PLUS

- » Unit with an innovative design and depth down to only 10 cm
- » Inverter-controlled BLDC motor
- » Low energy consumption
- » Modulating operation

Design-driven innovation

From the extensive experience of Galletti in the development and design of fan coil units, and in confirmation of its continuous search for innovation, has been created ART-U, the result of a perfect combination of performance and design.

The goal achieved by this project is absolutely ambitious: a new and unique product, not yet present on the market, which on the one hand is able to meet the increasingly stringent demands for energy efficiency, and, on the other hand, for the first time, reflect the latest trends in furnishings and interior design. With the new ART-U, this goal has been fully achieved, presenting on the market a new concept of hydronic indoor unit, a product that is characterized by its enviable technical performance and at the same time represents a true style shift in a field that has long been dominated by products that are all very similar to each other.

ART-U, with its depth down to only 10 cm, and thanks to its unique lines, was designed to be an absolutely all-purpose product, that adapts perfectly to rigorous and essential environments as well as to warmer and more sophisticated spaces. Thanks also to the possibility of customizing the front panel, ART-U meets the demand for ever more personalization of the spaces to be furnished. The achievement of extremely high aesthetic standards has not weakened the usual construction integrity of Galletti products: striving for innovation has in fact also focused on the components and the use of new materials. With ART-U the state of the art has been redefined also in terms of technical performance, thanks to the use of computational fluid dynamics simulations for the optimisation of the heat exchange inside the indoor unit combined with the use of permanent magnet electric motors.



MAIN COMPONENTS
Cabinet with a refined design

The elegant front panel consists of two sheets of aluminium with a polyethylene core and possibly a polyester-based surface coating. It is a light but very resistant material, created for covering façades in the building sector. The side panels are made of UV-stabilized ABS to maintain the colour over time. The polyethylene core acts as a flexible filler and thermal insulation while the aluminium provides structural strength and aesthetics.

Conveyors

Made of high-density polystyrene. They are designed to optimise the air flow inside the hydronic indoor unit allowing optimal distribution of the air flow in the coil and low noise in every operating mode.

Upper grille

Consisting of adjustable fins made of anodised aluminium, available in the version for on-board or wall-mounted control. The ABS combs support the grilles and prevent them from being bent, thus always guaranteeing the user's safety.

Front grille

Stabilizes the operation of the tangential fan unit and is equipped with a stainless steel filter.

Electric motor

Permanent magnet BLDC motor with inverter integrated in the ventilation unit. An IP54 protection rating is guaranteed; therefore, dust inside is avoided and resistance to water spray is guaranteed.

Tangential fans

Tangential fan, statically and dynamically balanced to reduce its noise during operation. The plastic material used for the blades guarantees, in comparison with metal fans, a reduction in vibrations and an absence of bending along the rotation axis. The blades are alternated with intermediate reinforcement disks in order to increase their sturdiness.

Heat exchangers

With high efficiency turbocoil-type heat exchanger, and made with copper tubing and aluminium fins, it is equipped with brass manifolds and a vent valve. The hydrophilic treatment is applied to the fins as a standard treatment, to increase their efficiency during cooling while at the same time providing greater resistance to aggressive environments. The water connections are reversible during installation. On request it is possible to mount an additional heat exchanger for 4-pipe systems.

Air filter

Honey-comb polypropylene washable filter, easily removable for maintenance operations.

AVAILABLE VERSIONS



ART-U Grey

The front panel made of brushed aluminium, combined with black side panels, was designed to enhance the reduced depth of the fan coil. The product, with simple, clean, and essential lines, fits perfectly in environments whose furnishings follows new trends and where a high level of design is required for each item.



ART-U White

The neutrality of the white ensures maximum integration with the space in an adaptive context, allowing the fan coil unit to almost disappear into the wall.

ART-U it can be customized with different color variations upon request.

COMPUTATIONAL FLUID DYNAMICS SIMULATIONS
The model

Computational Fluid Dynamics (CFD) is a method that uses numerical analysis to solve the problems of fluid dynamics by using computers.

For the ART-U project it was considered a computational domain discretized by means of a polyhedral calculation grid (mesh) consisting of 12 million cells.

The mesh has a refinement that extends to the entire rotor area to better reproduce the vorticity that is created in that area.

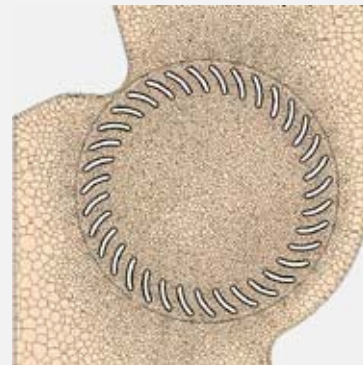
Air motion field

During the initial phase of development of the ART-U project the calculation showed the recirculation of the fluid downstream of the rotor in different areas, with consequent water pressure drop.

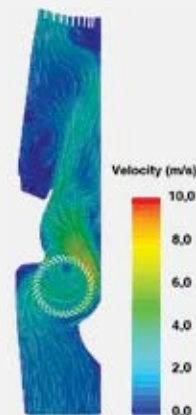
Flow lines

The flow lines show how the trajectory of the threads of liquid inside the unit does not have a uniform distribution.

For this reason, the research has also focused on improving the air distribution along the longitudinal axis of the fan unit, minimizing the wall interference effects.

The results of these simulations have allowed an optimisation of the geometry of the internal conveyor and the orientation of the finned block coil.

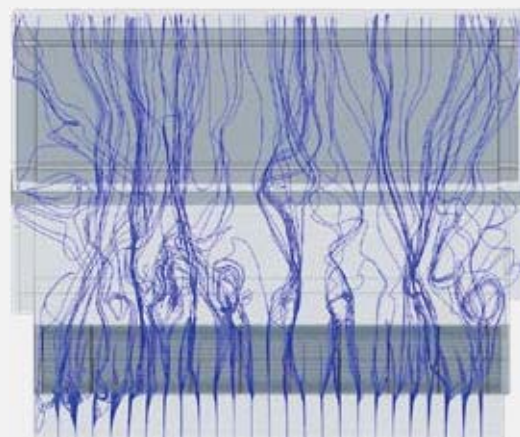

The final benefit obtained from the CFD simulations performed is a further improvement in the heat exchange, with a consequent reduction in power consumption and noise emissions with the same components and under the same operating conditions.

ACCESSORIES

EVOBOARD	Circuit board for EVO control	TED SWA	Water temperature sensor for TED controls
EVODISP	User interface with display for EVO controller	BV	Auxiliary water drip tray for vertical installation fan coil units
KBEVS	EVO on-board installation Kit for ART-U	GIVK	Insulating shell for VKS valve
MCLE	Microprocessor control with display MY COMFORT LARGE	PV	Rear painted panel for vertical installation with cabinet
MCSUE	Humidity sensor for MY COMFORT (medium e large), EVO	V2VSTD	2-way valve, ON/OFF or MODULATING actuator, 230 V or 24 V power supply, hydraulic kit, for main heat exchanger
MCSWE	Water sensor for MYCOMFORT, EVO, LED 503 controllers	V3VSTD	2-way valves, ON/OFF or MODULATING actuator, 230 V or 24 V power supply, hydraulic kit, for main heat exchanger
KBTES	On-board ART-U installation kit suitable for TED controller		
TED 10	Electronic controller for BLDC fan equipped with inverter and ON/OFF valves 230 V		

RATED TECHNICAL DATA

ART-U			10			20			30		
Speed			min	med	max	min	med	max	min	med	max
Control voltage		V	4,50	5,70	6,40	4,90	7,00	10,0	5,40	7,00	10,0
Total cooling capacity	(1)	kW	0,39	0,69	0,80	0,93	1,32	1,67	1,44	2,01	2,44
Sensible cooling capacity	(1)	kW	0,29	0,50	0,63	0,69	0,99	1,28	1,05	1,44	1,84
Total cooling capacity	(2)	kW	0,39	0,69	0,80	0,93	1,31	1,66	1,43	2,00	2,42
Sensible cooling capacity	(2)	kW	0,29	0,49	0,62	0,68	0,98	1,26	1,04	1,43	1,82
FCEER class			C			B			B		
Water flow	(1)	l/h	67	116	134	161	227	282	247	329	395
Water pressure drop	(1)	kPa	3	1	2	4	8	11	12	20	27
Heating capacity	(3)	kW	0,56	0,73	0,87	1,04	1,38	1,81	1,52	2,09	2,48
FCCOP class			C								
Water flow	(3)	l/h	98	126	146	169	238	303	261	413	413
Water pressure drop	(3)	kPa	3	1	2	4	7	12	11	20	27
Rated air flow		m ³ /h	110	141	179	190	275	391	295	390	528
Power input		W	4	5	6	7	11	17	10	14	23
Total sound power level		dB(A)	37	44	49	39	47	54	41	47	54

ART-U			40			50		
Speed			min	med	max	min	med	max
Control voltage		V	5,50	7,00	10,0	5,50	7,00	10,0
Total cooling capacity	(1)	kW	1,96	2,62	3,16	2,29	3,17	3,72
Sensible cooling capacity	(1)	kW	1,43	1,97	2,43	1,66	2,26	2,83
Total cooling capacity	(2)	kW	1,95	2,60	3,13	2,28	3,14	3,69
Sensible cooling capacity	(2)	kW	1,42	1,95	2,39	1,65	2,24	2,79
FCEER class			B			B		
Water flow	(1)	l/h	338	441	528	395	517	622
Water pressure drop	(1)	kPa	9	15	20	14	23	31
Heating capacity	(3)	kW	1,96	2,66	3,34	2,49	3,07	3,74
FCCOP class			C					
Water flow	(3)	l/h	360	457	557	416	528	644
Water pressure drop	(3)	kPa	8	14	20	14	20	28
Rated air flow		m ³ /h	412	529	715	474	609	824
Power input		W	14	20	32	16	23	36
Total sound power level		dB(A)	42	47	54	42	47	54

(1) Water temperature 7°C / 12°C, air temperature dry bulb 27°C, wet bulb 19°C (47% relative humidity)

(2) According to EN1397:2015

(3) Water temperature 45°C / 40°C, air temperature 20°C

Power supply 230-1-50 (V-ph-Hz)

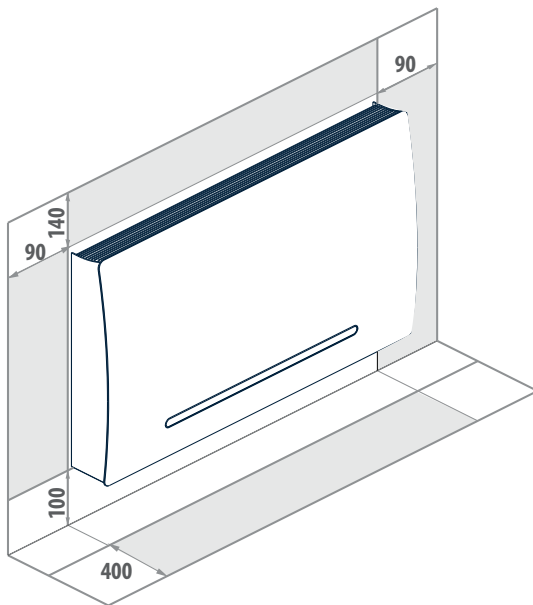
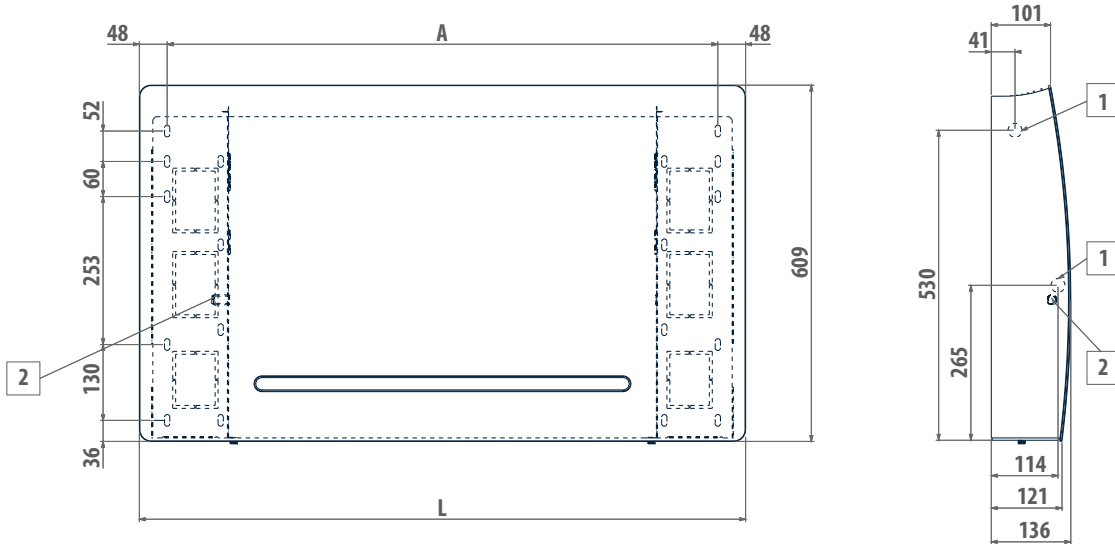
DIMENSIONAL DRAWINGS
ART-U

LEGEND

- | | |
|----------|--|
| 1 | Water connections standard heat exchanger ϕ 1/2" |
| 2 | Condensate discharge diameter for vertical installation ϕ 17 mm |

Mod.	A mm	L mm	 kg
ART-U 010	616	711	12
ART-U 020	772	867	14
ART-U 030	941	1036	17
ART-U 040	1173	1268	19
ART-U 050	1307	1402	21

Fan coil unit with design cabinet, 17 cm in depth

FLAT S 1 - 3 kW



The solution tailored to design requirements of residential applications

Galletti's FLAT series now becomes SLIM. In fact, with a depth of only 17 cm, FLAT S ensures a compact size that makes it easy to integrate in any context, thus responding to the new design trends in the residential sector (and beyond).

The FLAT S mini series means innovation also in terms of engineering: it combines a guarantee of excellent low-noise performance with the advantage of an exclusive design that fits well with both residential and commercial settings.

The stylishly designed cabinet (colour RAL9010) is compact and manufactured from steel sheet and UV-stabilised ABS. The upper grille includes a flap and adjustable louvers fitted with a microswitch that automatically shuts down the unit when the flap itself is closed.

The adoption of UV-stabilized ABS in the parts making up the cabinet and antistatic ABS in the fan assembly (volute and centrifugal fan) guarantee that the product will maintain the same aesthetics and noise levels throughout its lifetime.



PLUS

- » Cabinet with a refined design, depth 17 cm
- » Microswitch on air flap
- » Use of UV-stabilized ABS
- » Can be integrated into ERGO
- » Reversible water connections
- » 3-speed motor
- » ABS centrifugal fans



AVAILABLE VERSIONS



Suspended wall installation, with cabinet, with vertical air flow
2 and 4 pipes system

MAIN COMPONENTS

Cabinet

Design cabinet, RAL9010 colour, only 17 cm in depth, front panel made of sheet steel. Side panels and an upper grille with covers on either side manufactured from UV-stabilised ABS to maintain the colour intact over time. The upper grille consists of a flap and adjustable louvers. The flap features a microswitch that automatically shuts down the unit when the flap itself is closed.



Structure

Built from galvanised steel sheet of extra thickness, heat and sound insulated by means of Class 1 self-extinguishing panels.

Heat exchanger

High efficiency heat exchanger made with copper piping and aluminium fins, provided with brass manifolds and vent valve. The water connections are reversible at the time of installation. On request it is possible to mount an additional heat exchanger for 4-pipe systems.

Fans

Double suction centrifugal fans, statically and dynamically balanced, manufactured from anti-static ABS, with blades having an airfoil section and offset modules. The fans are housed in a low-noise ABS volute with high-efficiency profile.

Electric motor

It is mounted on vibration dampers, with permanently activated capacitor and thermal protection of the windings, and is directly coupled with the fans. It is available as either at 3- or (on request) 6-speed version in order to meet all the specific needs of performance, quietness, and power consumption.



Air filter

Honey-comb polypropylene washable air filter, easily removable for maintenance operations.

ACCESSORIES

Electromechanical control panels

CB	On-board speed switch
CD	Recess wall-mounted speed switch
CDE	Wall mounted speed selector
TC	Thermostat for minimum water temperature in heating mode (42 °C)
TD	Wall mounted control with speed selector, thermostat and summer-winter selector
TD4T	Wall-mounted speed selector, thermostat and summer/winter selecting switch, for controlling fan and valves
TDC	Wall mounted control with speed selector and thermostat
TIB	On-board speed switch, thermostat and summer/winter selecting switch

Electronic microprocessor control panels with display

COB	Finishing plate for LED 503 controller, RAL9005 black
COG	Finishing plate for LED 503 controller, RAL7031 grey
COW	Finishing plate for LED 503 controller, RAL9003 white
DIST	MY COMFORT controller spacer for wall mounting
EVOBOARD	Circuit board for EVO control
EVODISP	User interface with display for EVO controller
KBFLAE	MY COMFORT on-board installation KIT for FLAT
LED503	Recessed wall-mounted electronic display controller LED 503
MCBE	MYCOMFORT BASE electronic controller with display
MCLE	Microprocessor control with display MY COMFORT LARGE
MCME	MYCOMFORT MEDIUM electronic controller with display
MCSUE	Humidity sensor for MY COMFORT (medium e large), EVO
MCSWE	Water sensor for MYCOMFORT, EVO, LED 503 controllers

Electronic microprocessor control panels

KB F	On-board FLAT/FLAT S installation kit suitable for TED controller
TED 2T	Electronic controller for AC fan control and one ON/OFF 230 V valve
TED 4T	Electronic controller for AC fan control and two ON/OFF 230 V valves
TED SWA	Water temperature sensor for TED controls

Power interface and regulating louver controllers

KP	Power interface for connecting in parallel up to 4 fan coil units to the one controller
-----------	---

Additional heat exchanger for 4-pipe systems

DF	1-row additional coil for 4 pipes system
-----------	--

Auxiliary water drip trays, insulating shell, condensate drainage pump

BVK	Auxiliary water drip tray for vertical installation fan coil units
GIVKL	Insulating shell for VKS valve, water connections on the left
GIVKR	Insulating shell for VKS valve, water connections on the right

Base and enclosure elements

ZLS	Pair of base and enclosure elements for FLAT S
Rear covering panels	
PV	Rear painted panel for vertical installation with cabinet
Valves	
KV	2-way valve, ON/OFF actuator, hydraulic kit on water connection side for main heat exchanger
KV24	2-way valve, ON/OFF actuator, 24 V power supply, hydraulic kit on water connection side for main heat exchanger
KV24DF	2-way valve, ON/OFF actuator, 24 V power supply, hydraulic kit on water connection side for main and additional heat exchanger
KVDF	2-way valve, ON/OFF actuator, 230 V power supply, hydraulic kit on water connection side for main and additional heat exchanger
KVM	2-way valve, MODULATING actuator, 24 V power supply, hydraulic kit on water connection side for main heat exchanger
KVMDF	2-way valve, MODULATING actuator, 24 V power supply, hydraulic kit on water connection side for main and additional heat exchanger
VKDF	3-way valve, ON/OFF actuator, 230 V power supply, complete hydraulic kit for additional heat exchanger
VKDF24	3-way valve, ON/OFF actuator, 24 V power supply, complete hydraulic kit for additional heat exchanger
VKDF24ND	3-way valve, ON/OFF actuator, 24 V power supply, hydraulic kit without holder, for additional heat exchanger
VKDFND	3-way valve, ON/OFF actuator, 230 V power supply, hydraulic kit without holder, for additional heat exchanger
VKMF	3-way valve, MODULATING actuator, 24 V power supply, complete hydraulic kit for additional heat exchanger
VKMFND	3-way valve, MODULATING actuator, 24 V power supply, hydraulic kit without holder, for additional heat exchanger
VKMS	3-way valve, MODULATING actuator, 14 V power supply, complete hydraulic kit for main heat exchanger
VKMSND	3-way valve, MODULATING actuator, 24 V power supply, hydraulic kit without holder, for main heat exchanger
VKS	3-way valve, ON/OFF actuator, 1230 V power supply, complete hydraulic kit for main heat exchanger
VKS24	3-way valve, ON/OFF actuator, 24 V power supply, complete hydraulic kit for main heat exchanger
VKS24ND	3-way valve, ON/OFF actuator, 24 V power supply, hydraulic kit without holder, for main heat exchanger
VKSND	3-way valve, ON/OFF actuator, 230 V power supply, hydraulic kit without holder, for main heat exchanger

RATED TECHNICAL DATA

FLAT S			13			23			33			43		
Speed			min	med	max	min	med	max	min	med	max	min	med	max
Total cooling capacity	(1)	kW	0,86	0,98	1,24	1,09	1,34	1,75	1,41	1,76	2,32	1,76	2,14	2,78
Sensible cooling capacity	(1)	kW	0,61	0,70	0,89	0,75	0,93	1,22	1,02	1,27	1,69	1,27	1,55	2,03
Total cooling capacity	(2)(E)	kW	0,85	0,96	1,22	1,08	1,33	1,72	1,40	1,74	2,29	1,75	2,12	2,75
Sensible cooling capacity	(2)(E)	kW	0,60	0,68	0,87	0,74	0,91	1,19	1,00	1,24	1,65	1,25	1,52	1,99
FCEER class	(E)		D											
Water flow	(1)	l/h	148	168	213	186	230	300	243	303	399	303	368	477
Water pressure drop	(1)(E)	kPa	3	3	5	5	7	11	3	5	7	5	7	10
Heating capacity	(3)(E)	kW	1,07	1,21	1,52	1,21	1,47	1,93	1,81	2,21	2,88	2,21	2,66	3,42
Water pressure drop	(3)(E)	kPa	2	3	4	4	6	9	3	4	6	4	5	8
Heating capacity	(4)(E)	kW	0,89	1,01	1,27	1,00	1,22	1,59	1,52	1,85	2,40	1,85	2,22	2,86
FCCOP class	(E)		D											
Water flow	(4)	l/h	155	176	221	174	211	277	264	321	417	321	386	497
Water pressure drop	(4)(E)	kPa	2	3	4	3	5	8	3	4	7	4	6	9
Rated air flow		m ³ /h	115	135	170	135	170	225	200	250	340	250	310	420
Power input	(E)	W	12	17	23	14	20	27	23	28	37	25	31	42
Total sound power level	(E)	dB(A)	30	35	40	35	40	46	32	38	46	37	42	49
Heating capacity DF 1R	(5)(E)	kW	1,04	1,15	1,36	1,35	1,56	1,91	1,88	2,16	2,69	2,16	2,45	3,02
Water flow DF 1R	(5)	l/h	91	100	119	118	136	167	165	189	235	189	215	264
Water pressure drop DF 1R	(5)(E)	kPa	2	2	3	4	5	7	1	2	3	2	2	3

(1) Water temperature 7°C / 12°C, air temperature dry bulb 27°C, wet bulb 19°C (47% relative humidity)

(2) According to EN1397:2015

(3) Inlet water temperature 50°C, water flow rate same as in cooling mode, air temperature 20°C

(4) Water temperature 45°C / 40°C, air temperature 20°C

(5) Water temperature 65°C / 55°C, air temperature 20°C

(E) EUROVENT certified data

Power supply 230-1-50 (V-ph-Hz)

DIMENSIONAL DRAWINGS

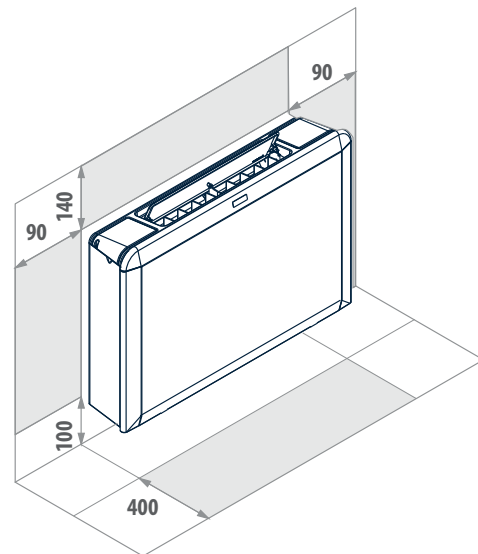
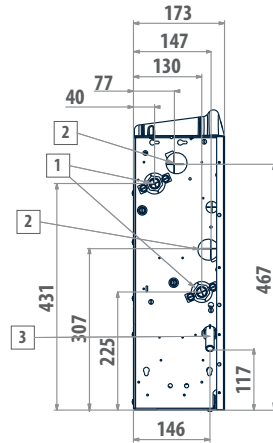
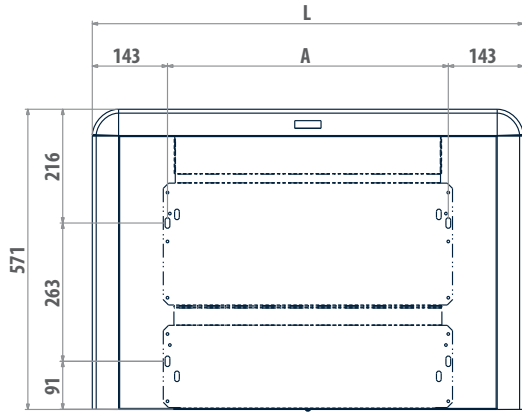
FLAT S

LEGEND

- 1** Water connections standard heat exchanger \varnothing 1/2"
- 2** DF 1-row additional heat exchanger water connections \varnothing 1/2"
- 3** Condensate discharge diameter for vertical installation \varnothing 16 mm

Condensate discharge diameter for horizontal installation \varnothing 17 mm

FLAT S	A mm	L mm	 kg
13	534	820	17
23	704	990	21
33 - 43	874	1160	23

Fan coil unit with design cabinet, only 17 cm in depth and BLDC motor **FLAT S i 1 - 3 kW**



PLUS

- » Cabinet with a refined design, depth 17 cm
- » Low energy consumption
- » Modulating operation
- » Microswitch on exit air flap
- » Can be integrated into ERGO
- » Reversible water connections
- » Inverter-controlled BLDC motor
- » ABS centrifugal fans

The solution tailored to design requirements of residential applications

Galletti's FLAT series now becomes SLIM. In fact, with a depth of only 17 cm, FLAT S ensures a compact size that makes it easy to integrate in any context, thus responding to the new design trends in the residential sector (and beyond).

The FLAT S mini series means innovation also in terms of engineering: it combines a guarantee of excellent low-noise performance with the advantage of an exclusive design that fits well with both residential and commercial settings.

The Galletti FLAT S i indoor hydronic units are equipped with a permanent magnet (brushless) electric motor, controlled by an inverter, which enables continuous adjustment in the number of fan revolutions.

In addition to the important reduction in electricity consumption compared to AC motors, the use of inverter BLDC technology makes it possible to continually adjust the operation of the unit to the actual thermo-hygrometric load of the interior, with a clear benefit in terms of comfort and reducing noise.

Its use is particularly effective in the frequent cases of operation under partial load conditions, the situation that occurs most frequently, when the adjustment logic allows greatly reduced motor rotation speeds with exceptional reductions in electricity consumption and noise emissions.

The operation of the unit with brushless motor is managed by EVO, MYCOMFORT LARGE or TED microprocessor control panel, using an analogue output (0-10 V) which is connected to the inverter.



AVAILABLE VERSIONS



Suspended wall installation, with cabinet, with vertical air flow
2 and 4 pipes system

MAIN COMPONENTS
Cabinet

Design cabinet, RAL9010 colour, only 17 cm in depth, front panel made of sheet steel. Side panels and an upper grille with covers on either side manufactured from UV-stabilised ABS to maintain the colour intact over time. The upper grille consists of a flap and adjustable louvers. The flap features a microswitch that automatically shuts down the unit when the flap itself is closed.

Structure

Built from galvanised steel sheet of extra thickness, heat and sound insulated by means of Class 1 self-extinguishing panels.

Heat exchanger

High efficiency heat exchanger made with copper piping and aluminium fins, provided with brass manifolds and vent valve. The water connections are reversible at the time of installation. On request it is possible to mount an additional heat exchanger for 4-pipe systems.

Fans

Double suction centrifugal fans, statically and dynamically balanced, manufactured from anti-static ABS, with blades having an airfoil section and offset modules. The fans are housed in a low-noise ABS volute with high-efficiency profile.

Electric motor

The unit is equipped with an inverter board to control the motor, which can be used separately or installed on the motor itself. This system makes it possible to precisely set the maximum rotation speed of the motor (control signal 0-10 V) even when the maximum rotation speed must be controlled to reduce noise levels.

Air filter

Honey-comb polypropylene washable air filter, easily removable for maintenance operations.

ACCESSORIES
Electronic microprocessor control panels with display

DIST	MY COMFORT controller spacer for wall mounting
EVOBOARD	Circuit board for EVO control
EVODISP	User interface with display for EVO controller
KBFLAE	MY COMFORT on-board installation KIT for FLAT
MCLE	Microprocessor control with display MY COMFORT LARGE
MCSUE	Humidity sensor for MY COMFORT (medium e large), EVO
MCSWE	Water sensor for MYCOMFORT, EVO, LED 503 controllers

Electronic microprocessor control panels

KB F	On-board FLAT/FLAT S installation kit suitable for TED controller
TED 10	Electronic controller for BLDC fan equipped with inverter and ON/OFF valves 230 V
TED SWA	Water temperature sensor for TED controls

Additional heat exchanger for 4-pipe systems

DF	1-row additional coil for 4 pipes system
Auxiliary water drip trays, insulating shell, condensate drainage pump	
BV	Auxiliary water drip tray for vertical installation fan coil units
GIVKL	Insulating shell for VKS valve, water connections on the left
GIVKR	Insulating shell for VKS valve, water connections on the right

Base and enclosure elements

ZLS	Pair of base and enclosure elements for FLAT S
------------	--

Rear covering panels

PV	Rear painted panel for vertical installation with cabinet
-----------	---

Valves

KV	2-way valve, ON/OFF actuator, hydraulic kit on water connection side for main heat exchanger
KV24	2-way valve, ON/OFF actuator, 24 V power supply, hydraulic kit on water connection side for main heat exchanger
KV24DF	2-way valve, ON/OFF actuator, 24 V power supply, hydraulic kit on water connection side for main and additional heat exchanger
KVDF	2-way valve, ON/OFF actuator, 230 V power supply, hydraulic kit on water connection side for main and additional heat exchanger
KVM	2-way valve, MODULATING actuator, 24 V power supply, hydraulic kit on water connection side for main heat exchanger
KVMDF	2-way valve, MODULATING actuator, 24 V power supply, hydraulic kit on water connection side for main and additional heat exchanger
VKDF	3-way valve, ON/OFF actuator, 230 V power supply, complete hydraulic kit for additional heat exchanger
VKDF24	3-way valve, ON/OFF actuator, 24 V power supply, complete hydraulic kit for additional heat exchanger
VKDF24ND	3-way valve, ON/OFF actuator, 24 V power supply, hydraulic kit without holder, for additional heat exchanger
VKDFND	3-way valve, ON/OFF actuator, 230 V power supply, hydraulic kit without holder, for additional heat exchanger
VKMFDF	3-way valve, MODULATING actuator, 24 V power supply, complete hydraulic kit for additional heat exchanger
VKMFND	3-way valve, MODULATING actuator, 24 V power supply, hydraulic kit without holder, for additional heat exchanger
VKMS	3-way valve, MODULATING actuator, 14 V power supply, complete hydraulic kit for main heat exchanger
VKMSND	3-way valve, MODULATING actuator, 24 V power supply, hydraulic kit without holder, for main heat exchanger
VKS	3-way valve, ON/OFF actuator, 1230 V power supply, complete hydraulic kit for main heat exchanger
VKS24	3-way valve, ON/OFF actuator, 24 V power supply, complete hydraulic kit for main heat exchanger
VKS24ND	3-way valve, ON/OFF actuator, 24 V power supply, hydraulic kit without holder, for main heat exchanger
VKSND	3-way valve, ON/OFF actuator, 230 V power supply, hydraulic kit without holder, for main heat exchanger

RATED TECHNICAL DATA

FLAT S i			13			23			43		
Speed			min	med	max	min	med	max	min	med	max
Control voltage	(E)	V	4,80	5,80	7,70	4,50	5,80	7,90	5,10	6,30	8,00
Total cooling capacity	(1)	kW	0,86	0,98	1,24	1,09	1,34	1,75	1,76	2,14	2,78
Sensible cooling capacity	(1)	kW	0,61	0,70	0,89	0,75	0,93	1,22	1,27	1,55	2,03
Total cooling capacity	(2)(E)	kW	0,85	0,97	1,23	1,08	1,33	1,74	1,75	2,12	2,75
Sensible cooling capacity	(2)(E)	kW	0,60	0,69	0,88	0,74	0,92	1,21	1,26	1,54	2,01
FCEER class	(E)		B								
Water flow	(1)	l/h	148	168	213	186	230	300	303	368	477
Water pressure drop	(1)(E)	kPa	3	3	5	5	7	11	5	7	10
Heating capacity	(3)(E)	kW	1,07	1,21	1,52	1,21	1,47	1,93	2,21	2,66	3,42
Water pressure drop	(3)(E)	kPa	2	3	4	4	6	9	4	5	8
Heating capacity	(4)(E)	kW	0,89	1,01	1,27	1,00	1,22	1,59	1,85	2,22	2,86
FCCOP class	(E)		C			B			B		
Water flow	(4)	l/h	155	176	221	174	211	277	321	386	497
Water pressure drop	(4)(E)	kPa	2	3	4	3	5	8	4	6	9
Rated air flow		m ³ /h	115	135	170	135	170	225	250	310	420
Power input	(E)	W	7	8	10	7	8	11	10	12	21
Total sound power level	(E)	dB(A)	30	35	40	35	40	46	37	42	49
Heating capacity DF 1R	(5)(E)	kW	1,04	1,15	1,36	1,35	1,56	1,91	2,16	2,45	3,02
Water flow DF 1R	(5)	l/h	91	100	119	118	136	167	189	215	264
Water pressure drop DF 1R	(5)(E)	kPa	2	2	3	4	5	7	2	2	3

(1) Water temperature 7°C / 12°C, air temperature dry bulb 27°C, wet bulb 19°C (47% relative humidity)

(2) According to EN1397:2015

(3) Inlet water temperature 50°C, water flow rate same as in cooling mode, air temperature 20°C

(4) Water temperature 45°C / 40°C, air temperature 20°C

(5) Water temperature 65°C / 55°C, air temperature 20°C

(E) EUROVENT certified data

Power supply 230-1-50 (V-ph-Hz)

DIMENSIONAL DRAWINGS

FLAT Si

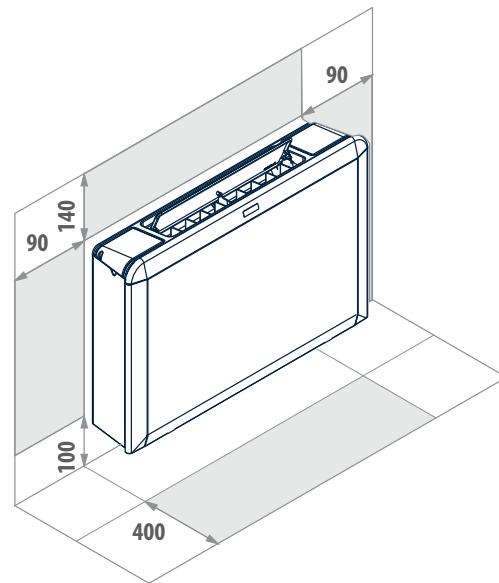
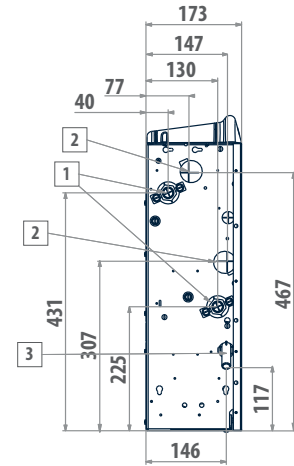
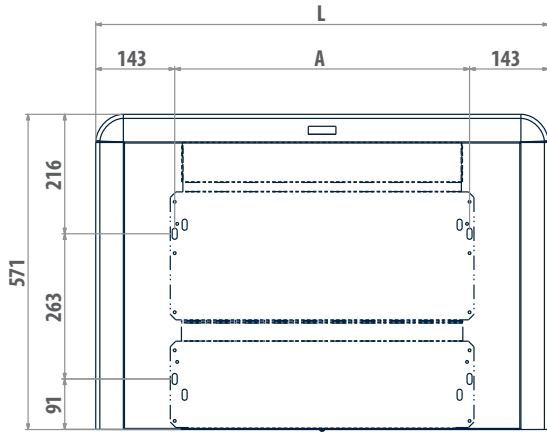

LEGEND

- 1 Water connections standard heat exchanger \varnothing 1/2"
- 2 DF 1-row additional heat exchanger water connections \varnothing 1/2"
- 3 Condensate discharge diameter for vertical installation \varnothing 16 mm
Condensate discharge diameter for horizontal installation \varnothing 17 mm

FLAT Si	A mm	L mm	 kg
13	534	820	17
23	704	990	21
43	874	1160	23

Design fan coil units with centrifugal fan

FLAT 2 - 5 kW



Galletti FLAT: performance and design in a single indoor unit

FLAT Galletti has been engineered to offer performance and design features placing it at the top of its category. The uniqueness of FLAT lies both in the use of extremely high quality materials - which contribute to making this product exceptionally robust - and the assurance of constant performance over time.

FLAT optimizes the distribution of air in the room thanks to the integrated air outlet grille which makes it possible to direct the treated, filtered air in 4 directions. The main flap is equipped with a microswitch which shuts off the fan and the valves when the flap closes. The flap is useful for avoiding dust build-up in periods of non-use.

The adoption of UV-stabilized ABS in the parts making up the cabinet and antistatic ABS in the fan assembly (volute and centrifugal fan) guarantee that the product will maintain the same aesthetics and noise levels throughout its lifetime.

Particular care has been taken in the design of the fan drive assembly, which guarantees exceptionally quiet operation both in version with 3- and 6-speed motors.

The conception underlying its construction makes it possible to combine models for vertical and horizontal installation: 2 different versions enable FLAT to be installed on the floor, wall and ceiling.

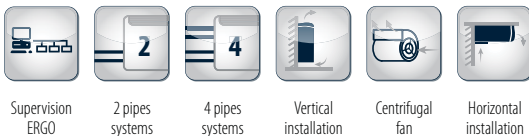

PLUS

- » Cabinet with a refined design
- » Microswitch on exit air flap
- » Use of UV-stabilized ABS
- » Reversible water connections
- » 3 - 6 speed motor
- » ABS centrifugal fans
- » Can be integrated into ERGO
- » Incorporable ioniser



AVAILABLE VERSIONS



FLAT L
Suspended wall installation, with cabinet, with vertical air flow.



FLAT U
Floor or ceiling mounted, with cabinet, with vertical air flow and air intake grille complete with filters.

MAIN COMPONENTS

Cabinet

RAL9010 colour, front panel made of sheet steel. Side panels and an upper grille with covers on either side manufactured from UV-stabilised ABS to maintain the colour intact over time. The upper grille consists of a flap and adjustable louvers. The flap features a microswitch that automatically shuts down the unit when the flap itself is closed.



Structure

Built from galvanised steel sheet of extra thickness, heat and sound insulated by means of Class 1 self-extinguishing panels. FLAT U version is suitable for either horizontal or vertical installation thanks to the dual condensate collection and drainage system.

Heat exchanger

High efficiency heat exchanger made with copper piping and aluminium fins, provided with brass manifolds and vent valve. The water connections are reversible at the time of installation. On request it is possible to mount an additional heat exchanger for 4-pipe systems.

Fans

Double suction centrifugal fans, statically and dynamically balanced, manufactured from anti-static ABS, with blades having an airfoil section and offset modules. The fans are housed in a low-noise ABS volute with high-efficiency profile.

Electric motor

It is mounted on vibration dampers, with permanently activated capacitor and thermal protection of the windings, and is directly coupled with the fans. It is available as either a 3- or 6-speed version in order to meet all the specific needs of performance, quietness, and power consumption.



Air filter

Honey-comb polypropylene washable air filter, easily removable for maintenance operations. On FLAT FU version the air filters are fitted onto the air inlet grille.

ACCESSORIES

Electromechanical control panels

CB	On-board speed switch
CD	Recess wall-mounted speed switch
CDE	Wall mounted speed selector
TA	Wall-mounted room thermostat
TA2	Electromechanical room thermostat with summer/winter selection
TC	Thermostat for minimum water temperature in heating mode (42 °C)
TD	Wall mounted control with speed selector, thermostat and summer-winter selector
TD4T	Wall-mounted speed selector, thermostat and summer/winter selecting switch, for controlling fan and valves
TIB	On-board speed switch, thermostat and summer/winter selecting switch

Electronic microprocessor control panels with display

COB	Finishing plate for LED 503 controller, RAL9005 black
COG	Finishing plate for LED 503 controller, RAL7031 grey
COW	Finishing plate for LED 503 controller, RAL9003 white
DIST	MY COMFORT controller spacer for wall mounting
EVOBOARD	Circuit board for EVO control
EVO DISP	User interface with display for EVO controller
KBFLAE	MY COMFORT on-board installation kit for FLAT
LED503	Recessed wall-mounted electronic display controller LED 503
MCBE	MYCOMFORT BASE electronic controller with display
MCLE	Microprocessor control with display MY COMFORT LARGE
MCME	MYCOMFORT MEDIUM electronic controller with display
MCSUE	Humidity sensor for MY COMFORT (medium e large), EVO
MCSWE	Water sensor for MYCOMFORT, EVO, LED 503 controllers

Electronic microprocessor control panels

KB F	On-board FLAT/FLAT S installation kit suitable for TED controller
TED 2T	Electronic controller for AC fan control and one ON/OFF 230 V valve
TED 4T	Electronic controller for AC fan control and two ON/OFF 230 V valves
TED SWA	Water temperature sensor for TED controls

Power interface and regulating louver controllers

KP	Power interface for connecting in parallel up to 4 fun coil units to the one controller
-----------	---

Additional heat exchanger for 4-pipe systems

DF	1-row additional coil for 4 pipes system
Auxiliary water drip trays, insulating shell, condensate drainage pump	
BH	Auxiliary water drip tray for horizontal installation fan coil units
BV	Auxiliary water drip tray for vertical installation fan coil units
GIVKL	Insulating shell for VKS valve, water connections on the left
GIVKR	Insulating shell for VKS valve, water connections on the right

Base and enclosure elements

ZL	Pair of base and enclosure elements for FLAT L
Rear covering panels	
PH	Rear painted panel for horizontal installation with cabinet
PV	Rear painted panel for vertical installation with cabinet

Valves

V2VDF+STD	2-way valves, ON/OFF or MODULATING actuator, 230 V or 24 V power supply, hydraulic kit, for main and additional heat exchanger
V2VSTD	2-way valve, ON/OFF or MODULATING actuator, 230 V or 24 V power supply, hydraulic kit, for main heat exchanger
V3VDF	3-way valves, ON/OFF or MODULATING actuator, 230 V or 24 V power supply, hydraulic kit, for additional heat exchanger
V3VSTD	2-way valves, ON/OFF or MODULATING actuator, 230 V or 24 V power supply, hydraulic kit, for main heat exchanger

RATED TECHNICAL DATA

FLAT			10			20			30			40		
Speed			min	med	max	min	med	max	min	med	max	min	med	max
Total cooling capacity	(1)	kW	1,30	1,46	1,93	1,39	1,74	2,27	1,47	2,04	2,71	1,69	2,32	2,92
Sensible cooling capacity	(1)	kW	0,95	1,06	1,40	1,04	1,32	1,72	1,12	1,57	2,09	1,30	1,79	2,25
Total cooling capacity	(2)(E)	kW	1,28	1,44	1,90	1,37	1,70	2,21	1,44	2,00	2,65	1,66	2,27	2,86
Sensible cooling capacity	(2)(E)	kW	0,93	1,04	1,37	1,02	1,28	1,66	1,09	1,53	2,03	1,27	1,75	2,19
FCEER class	(E)		D			E			E			D		
Water flow	(1)	l/h	224	251	331	239	299	390	251	351	465	290	398	501
Water pressure drop	(1)(E)	kPa	5	6	10	6	8	13	3	5	7	4	6	10
Heating capacity	(3)(E)	kW	1,57	1,75	2,31	1,81	2,19	2,86	1,85	2,46	3,27	2,10	2,78	3,48
Water pressure drop	(3)(E)	kPa	4	5	9	5	7	11	2	4	6	3	5	8
Heating capacity	(4)(E)	kW	1,16	1,29	1,71	1,52	1,84	2,39	1,55	2,04	2,72	1,76	2,32	2,89
FCCOP class	(E)		D			E			E			E		
Water flow	(4)	l/h	200	222	295	264	319	416	269	356	473	305	402	503
Water pressure drop	(4)(E)	kPa	4	5	9	6	8	12	2	4	6	3	5	8
Rated air flow		m ³ /h	197	226	305	216	284	378	240	344	467	283	407	520
Power input	(E)	W	19	23	33	25	38	57	28	43	57	29	45	60
Total sound power level	(E)	dB(A)	32	36	44	38	44	50	30	38	44	33	42	48
Heating capacity DF 1R	(5)(E)	kW	1,35	1,46	1,76	1,44	1,65	1,96	1,78	2,13	2,59	1,96	2,35	2,74
Water flow DF 1R	(5)	l/h	118	128	154	126	144	172	156	187	227	172	205	240
Water pressure drop DF 1R	(5)(E)	kPa	3	3	5	3	4	6	6	9	12	7	10	13

FLAT			50			60			70		
Speed			min	med	max	min	med	max	min	med	max
Total cooling capacity	(1)	kW	2,08	2,61	3,32	2,24	2,97	4,16	2,56	3,35	4,46
Sensible cooling capacity	(1)	kW	1,65	2,06	2,60	1,80	2,39	3,37	2,08	2,75	3,70
Total cooling capacity	(2)(E)	kW	2,04	2,55	3,24	2,20	2,91	4,07	2,52	3,29	4,36
Sensible cooling capacity	(2)(E)	kW	1,61	2,00	2,52	1,76	2,33	3,28	2,04	2,69	3,60
FCEER class	(E)		E			D			D		
Water flow	(1)	l/h	357	448	569	384	510	714	440	575	766
Water pressure drop	(1)(E)	kPa	3	4	6	3	5	8	8	13	23
Heating capacity	(3)(E)	kW	2,67	3,20	4,03	3,10	3,97	5,47	3,49	4,44	5,88
Water pressure drop	(3)(E)	kPa	2	3	5	2	4	7	7	11	21
Heating capacity	(4)(E)	kW	2,24	2,67	3,36	2,64	3,36	4,61	2,96	3,76	4,96
FCCOP class	(E)		E			D			D		
Water flow	(4)	l/h	389	464	584	459	584	802	516	653	862
Water pressure drop	(4)(E)	kPa	3	4	5	3	5	8	8	14	22
Rated air flow		m ³ /h	370	466	593	406	552	800	482	659	911
Power input	(E)	W	40	56	75	38	58	88	41	65	96
Total sound power level	(E)	dB(A)	36	42	50	42	48	56	43	51	58
Heating capacity DF 1R	(5)(E)	kW	2,55	2,87	3,36	2,70	3,15	3,91	2,98	3,46	4,16
Water flow DF 1R	(5)	l/h	223	251	295	236	276	342	261	303	365
Water pressure drop DF 1R	(5)(E)	kPa	2	3	4	2	3	4	3	3	5

- (1) Water temperature 7°C / 12°C, air temperature dry bulb 27°C, wet bulb 19°C (47% relative humidity)
 (2) According to EN1397:2015
 (3) Inlet water temperature 50°C, water flow rate same as in cooling mode, air temperature 20°C
 (4) Water temperature 45°C / 40°C, air temperature 20°C
 (5) Water temperature 65°C / 55°C, air temperature 20°C
 (E) EUROVENT certified data
 Power supply 230-1-50 (V-ph-Hz)

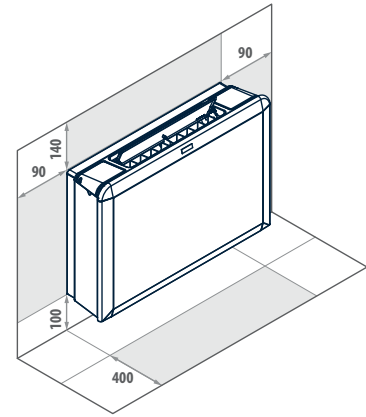
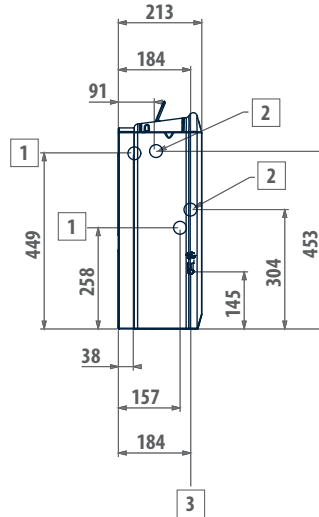
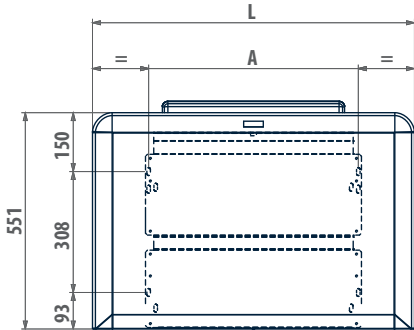
DIMENSIONAL DRAWINGS
FLAT L

LEGEND

- 1** Water connections standard heat exchanger \varnothing 1/2"
- 2** DF 1-row additional heat exchanger water connections \varnothing 1/2"
- 3** Condensate discharge diameter for vertical installation \varnothing 16 mm
- \varnothing Condensate discharge diameter for horizontal installation \varnothing 17 mm

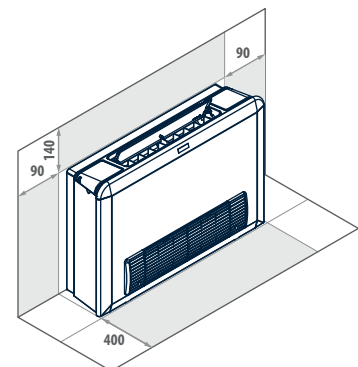
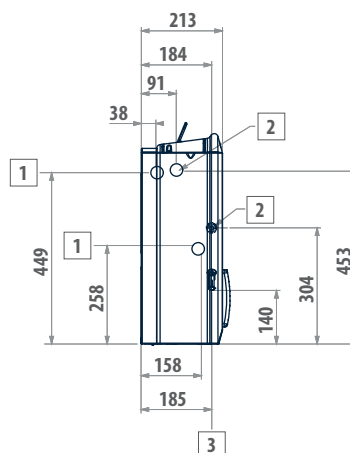
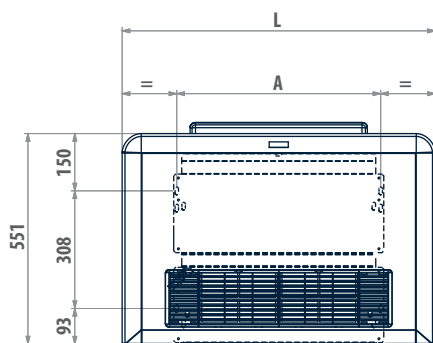
FLAT L	A mm	L mm	 kg
10 - 20	534	820	19
30 - 40	704	990	23
50 - 60 - 70	874	1160	28

FLAT U

LEGEND

- 1** Water connections standard heat exchanger \varnothing 1/2"
- 2** DF 1-row additional heat exchanger water connections \varnothing 1/2"
- 3** Condensate discharge diameter for vertical installation \varnothing 16 mm
- \varnothing Condensate discharge diameter for horizontal installation \varnothing 17 mm

FLAT U	A mm	L mm	 kg
10 - 20	534	820	20
30 - 40	704	990	25
50 - 60 - 70	874	1160	29

Design fan coil unit with centrifugal fan and BLDC motor

FLAT i 2 - 5 kW



Technology and design in a single solution

The Galletti FLAT i indoor hydronic units are equipped with a permanent magnet (brushless) electric motor, controlled by an inverter, which enables continuous adjustment in the number of fan revolutions.

In addition to the important reduction in electricity consumption compared to AC motors, the use of inverter BLDC technology makes it possible to continually adjust the operation of the unit to the actual thermo-hygrometric load of the interior, with a clear benefit in terms of comfort and reducing noise.

Its use is particularly effective in the frequent cases of operation under partial load conditions, the situation that occurs most frequently, when the adjustment logic allows greatly reduced motor rotation speeds with exceptional reductions in electricity consumption and noise emissions.

The operation of the unit with brushless motor is managed by EVO, MYCOMFORT LARGE or TED microprocessor control panel, using an analogue output (0-10 V) which is connected to the inverter.

PLUS

- » Inverter-controlled BLDC motor
- » Low energy consumption
- » Modulating operation
- » ABS centrifugal fans
- » Can be integrated into ERGO
- » Cabinet with a refined design in UV-stabilized ABS
- » Microswitch on exit air flap
- » Reversible water connections



AVAILABLE VERSIONS



FLAT L i

Suspended wall installation, with cabinet, with vertical air flow.



FLAT U i

Floor or ceiling mounted, with cabinet, with vertical air flow and air intake grille complete with filters.

MAIN COMPONENTS

Cabinet with a refined design

RAL9010 colour, front panel made of sheet steel. Side panels and an upper grille with covers on either side manufactured from UV-stabilised ABS to maintain the colour intact over time. The upper grille consists of a flap and adjustable louvers. The flap features a microswitch that automatically shuts down the unit when the flap itself is closed.



Structure

Built from galvanised steel sheet of extra thickness, heat and sound insulated by means of Class 1 self-extinguishing panels. FLAT U version is suitable for either horizontal or vertical installation thanks to the dual condensate collection and drainage system.

Heat exchanger

High efficiency heat exchanger made with copper piping and aluminium fins, provided with brass manifolds and vent valve. The water connections are reversible at the time of installation. On request it is possible to mount an additional heat exchanger for 4-pipe systems.

Fans

Double suction centrifugal fans, statically and dynamically balanced, manufactured from anti-static ABS, with blades having an airfoil section and offset modules. The fans are housed in a low-noise ABS volute with high-efficiency profile.

BLDC electric motor

The unit is equipped with an inverter board to control the motor, which can be used separately or installed on the motor itself. This system makes it possible to precisely set the maximum rotation speed of the motor (control signal 0-10 V) even when the maximum rotation speed must be controlled to reduce noise levels.

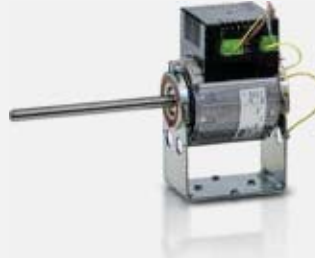

Air filter

Honey-comb polypropylene washable air filter, easily removable for maintenance operations. On FLAT U version the air filters are fitted onto the air inlet grille.

ACCESSORIES

Electronic microprocessor control panels with display

DIST	MY COMFORT controller spacer for wall mounting
EVOBOARD	Circuit board for EVO control
EVODISP	User interface with display for EVO controller
KBFLAE	MY COMFORT on-board installation KIT for FLAT
MCLE	Microprocessor control with display MY COMFORT LARGE
MCSUE	Humidity sensor for MY COMFORT (medium e large), EVO
MCSWE	Water sensor for MYCOMFORT, EVO, LED 503 controllers

Electronic microprocessor control panels

KB F	On-board FLAT/FLAT S installation kit suitable for TED controller
TED 10	Electronic controller for BLDC fan equipped with inverter and ON/OFF valves 230 V
TED SWA	Water temperature sensor for TED controls

Additional heat exchanger for 4-pipe systems

DF	1-row additional coil for 4 pipes system
-----------	--

Auxiliary water drip trays, insulating shell, condensate drainage pump

BH	Auxiliary water drip tray for horizontal installation fan coil units
-----------	--

BV	Auxiliary water drip tray for vertical installation fan coil units
GIVKL	Insulating shell for VKS valve, water connections on the left
GIVKR	Insulating shell for VKS valve, water connections on the right

Base and enclosure elements

ZL	Pair of base and enclosure elements for FLAT L
-----------	--

Rear covering panels

PH	Rear painted panel for horizontal installation with cabinet
PV	Rear painted panel for vertical installation with cabinet

Valves

V2VDF+STD	2-way valves, ON/OFF or MODULATING actuator, 230 V or 24 V power supply, hydraulic kit, for main and additional heat exchanger
V2VSTD	2-way valve, ON/OFF or MODULATING actuator, 230 V or 24 V power supply, hydraulic kit, for main heat exchanger
V3VDF	3-way valves, ON/OFF or MODULATING actuator, 230 V or 24 V power supply, hydraulic kit, for additional heat exchanger
V3VSTD	2-way valves, ON/OFF or MODULATING actuator, 230 V or 24 V power supply, hydraulic kit, for main heat exchanger

RATED TECHNICAL DATA

FLAT i			20			40			70		
Speed			min	med	max	min	med	max	min	med	max
Control voltage	(E)	V	6,10	8,10	8,30	4,60	6,80	8,60	5,80	8,30	8,50
Total cooling capacity	(1)	kW	1,44	1,81	2,27	1,74	2,39	2,92	2,64	3,46	4,46
Sensible cooling capacity	(1)	kW	1,06	1,32	1,72	1,32	1,83	2,26	2,12	2,80	3,70
Total cooling capacity	(2)(E)	kW	1,43	1,80	2,25	1,73	2,38	2,90	2,63	3,44	4,41
Sensible cooling capacity	(2)(E)	kW	1,05	1,31	1,70	1,31	1,82	2,24	2,11	2,78	3,65
FCEER class	(E)		B			A			B		
Water flow	(1)	l/h	247	310	390	299	411	501	454	593	765
Water pressure drop	(1)(E)	kPa	6	9	13	4	7	10	4	7	11
Heating capacity	(3)(E)	kW	1,82	2,23	2,86	2,18	2,90	3,48	3,62	4,63	5,87
Water pressure drop	(3)(E)	kPa	5	7	11	3	5	8	3	5	9
Heating capacity	(4)(E)	kW	1,52	1,84	2,39	1,76	2,32	2,89	2,96	3,76	4,96
FCCOP class	(E)		B								
Water flow	(4)	l/h	264	319	416	305	402	503	516	653	862
Water pressure drop	(4)(E)	kPa	6	8	12	3	5	8	8	14	22
Rated air flow		m ³ /h	216	284	378	283	407	520	482	659	911
Power input	(E)	W	7	11	22	7	12	24	13	21	49
Total sound power level	(E)	dB(A)	38	44	50	33	41	48	43	51	58
Heating capacity DF 1R	(5)(E)	kW	1,44	1,65	1,96	1,96	2,35	2,74	2,98	3,46	4,16
Water flow DF 1R	(5)	l/h	126	144	172	172	205	240	261	303	365
Water pressure drop DF 1R	(5)(E)	kPa	3	4	6	7	10	13	3	3	5

(1) Water temperature 7°C / 12°C, air temperature dry bulb 27°C, wet bulb 19°C (47% relative humidity)

(2) According to EN1397:2015

(3) Inlet water temperature 50°C, water flow rate same as in cooling mode, air temperature 20°C

(4) Water temperature 45°C / 40°C, air temperature 20°C

(5) Water temperature 65°C / 55°C, air temperature 20°C

(E) EUROVENT certified data

Power supply 230-1-50 (V-ph-Hz)

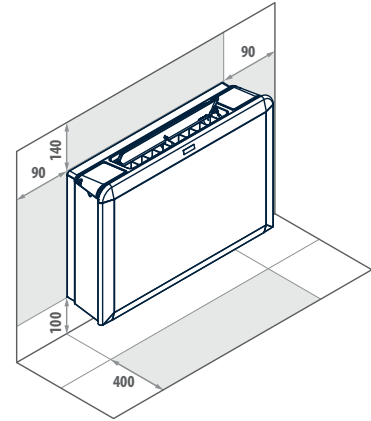
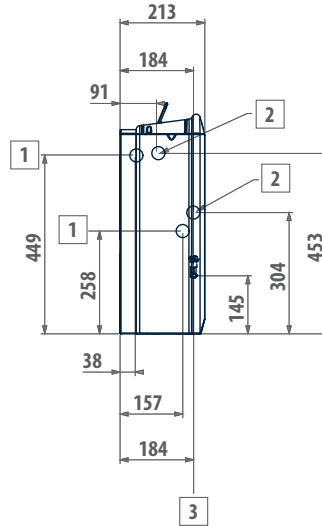
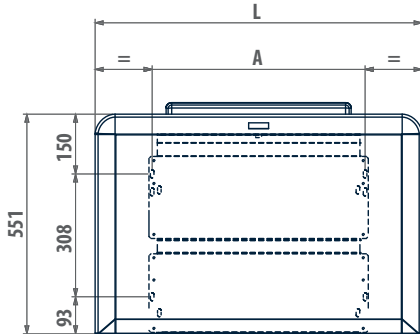
DIMENSIONAL DRAWINGS
FLAT Li

LEGEND

- 1** Water connections standard heat exchanger \varnothing 1/2"
- 2** DF 1-row additional heat exchanger water connections \varnothing 1/2"
- 3** Condensate discharge diameter for vertical installation \varnothing 16 mm
- \varnothing Condensate discharge diameter for horizontal installation \varnothing 17 mm

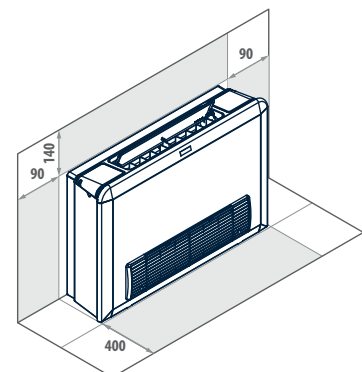
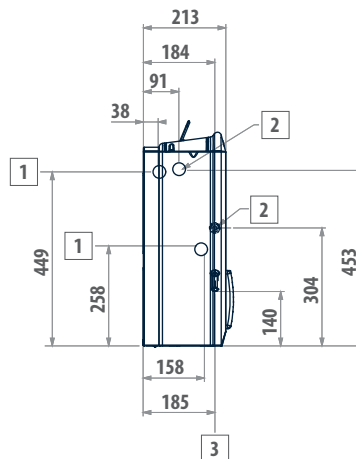
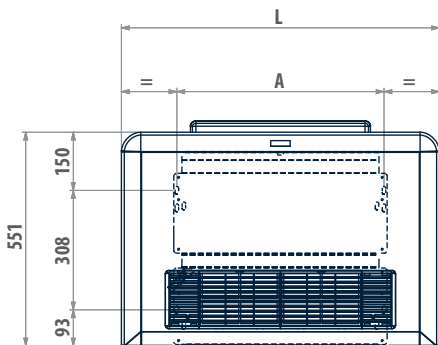
FLAT Li	A mm	L mm	 kg
20	534	820	19
40	704	990	23
70	874	1160	28

FLAT Ui

LEGEND

- 1** Water connections standard heat exchanger \varnothing 1/2"
- 2** DF 1-row additional heat exchanger water connections \varnothing 1/2"
- 3** Condensate discharge diameter for vertical installation \varnothing 16 mm
- \varnothing Condensate discharge diameter for horizontal installation \varnothing 17 mm

FLAT Ui	A mm	L mm	 kg
20	534	820	20
40	704	990	25
70	874	1160	29

High wall-mounted fan coil units

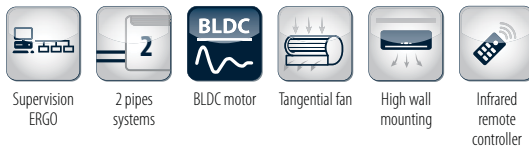
FM 2 - 4 kW



New Galletti hydronic indoor unit which combines quiet operation, a refined design and comfort control

FM stands out for its advanced technological features, including a BLDC motor, incorporated adjustment valve and serial communication.

Automatic control of the fan speed is managed through a proportional, integrative and derivative logic capable of ensuring stability, precision and rapid intervention, respectively.

The serial communication enables the interaction of up to 32 units, thus guaranteeing a global management with automatic adjustment of the parameters on all units coordinated from a single point.

With the WALLPAD accessory it is possible to control the units connected in the system one by one.

FM can be interconnected with a supervision system with Modbus communication.

On the one hand the valve already installed on the unit and the system of hoses permits fast, safe installation, and on the other hand the BLDC fan motor technology and coil providing an optimized heat exchange offer the user a quiet, high-performance, energy efficient indoor unit.

PLUS

- » Electronically controlled BLDC motor
- » Compact dimensions, identical for the whole range
- » Incorporated 2- or 3- way ON OFF valves
- » PID regulation
- » Construction of global addressable networks with an external supervisor



23/33/43 models

These models are characterized by the presence of a 3-way valve installed on the unit which allows it to be integrated into any type of installation, in particular in the presence of ON OFF pumps.

22/32/42 models

The models with a 2-way valve already installed on them can be perfectly adapted to systems which include a modulating circulator or another means for varying the water flow.

MAIN COMPONENTS

Cabinet

The ABS cabinet features attractive design, for every type of environment. The integrated air outlet is equipped with a motor driven flap that can sweep automatically or be positioned manually, and adjustable fins for a uniform distribution of air in the room. The front panel is complete with display to show all the functions of the unit and the room temperature.

Heat exchanger

The finned block heat exchangers consist of copper tubing and aluminium fins. The hydrophilic treatment on the fins assures an optimal heat exchange even in the presence of surface condensation.



Valve assembly

Two- or three-way ON/OFF valves already wired and installed inside the indoor unit. The connection to the system is made with hoses located on the rear of the unit. Without any increase in dimensions or complications in installation, the valve closes on reaching the set point, recirculating the flow of water and preventing it from entering the heat exchanger.

Remote control

Supplied as a standard feature, the infrared controller can be used to control a single indoor unit or a combined network and to program daily time slots.



BLDC motor

Permanent magnet electronic motor enabling continuous modulation of the fan speed with electricity consumption reduced by more than one half compared to asynchronous motors.

Fan

Low-noise tangential fan.



WALLPAD

The true strong point of this controller is tied to the development of communication networks. By connecting up to 32 units via a network bus and connecting the WALLPAD controller to one of them (Master) it is possible to control their operation. In particular, the user can choose whether to communicate simultaneously with all of the connected units, for example to change the operating mode of the entire system, or dialogue with each individual unit, differentiating the settings between one fan coil and another. The selection of "global" communication or communication with a single indoor unit is made by simply pressing a button.

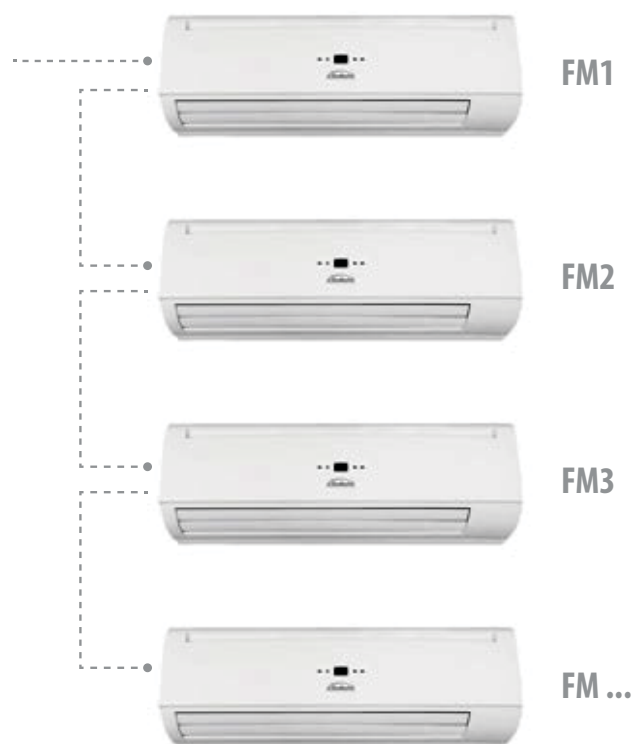

ACCESSORIES

Wire remote control

WALLPAD

The wired controller, which may be mounted on the wall, enables advanced control of the hydronic indoor unit. In particular the controller provides the user with detailed information concerning the operating status of the unit at any given time, including temperature, set point, speed, operating mode, flap movement and a lot of other information. It also implements a weekly control of the time slots with an on/off timer.

RATED TECHNICAL DATA

FM			22 / 23			32 / 33			42 / 43		
Speed			min	med	max	min	med	max	min	med	max
Total cooling capacity	(1)	kW	1,36	1,63	2,05	1,86	2,47	3,01	2,66	3,26	3,71
Sensible cooling capacity	(1)	kW	1,00	1,20	1,52	1,35	1,81	2,22	1,94	2,40	2,74
Total cooling capacity	(2)(E)	kW	1,36	1,63	2,05	1,86	2,46	3,01	2,66	3,26	3,71
Sensible cooling capacity	(2)(E)	kW	0,99	1,19	1,50	1,34	1,80	2,20	1,93	2,38	2,71
FCEER class			B								
Water flow	(1)	l/h	236	282	356	322	427	521	459	564	643
Water pressure drop	(1)(E)	kPa	12	19	29	16	28	39	28	40	50
2/3-way valve pressure drop	(1)	kPa	2	3	5	5	6	11	11	17	22
Heating capacity	(3)(E)	kW	1,72	2,08	2,64	2,34	3,14	3,85	3,37	4,17	4,77
Water pressure drop	(3)(E)	kPa	11	15	22	14	25	35	25	36	45
Heating capacity	(4)(E)	kW	1,45	1,76	2,23	2,07	2,65	3,25	3,12	3,86	4,06
FCCOP class	(E)		C			B			B		
Water flow	(4)	l/h	251	303	386	340	458	562	492	609	697
Water pressure drop	(4)(E)	kPa	12	17	29	17	28	39	32	46	52
Rated air flow		m ³ /h	290	370	500	370	445	645	570	740	876
Power input	(E)	W	10	13	18	10	15	22	13	20	30
Total sound power level	(E)	dB(A)	35	40	48	40	43	54	46	53	58

(1) Water temperature 7°C / 12°C, air temperature dry bulb 27°C, wet bulb 19°C (47% relative humidity)

(2) According to EN1397:2015

(3) Inlet water temperature 50°C, water flow rate same as in cooling mode, air temperature 20°C

(4) Water temperature 45°C / 40°C, air temperature 20°C

(E) EUROVENT certified data

Power supply 230-1-50 or 220/-1-60 (V-ph-Hz)

DIMENSIONAL DRAWINGS

FM

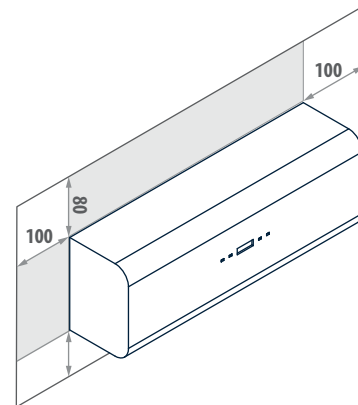
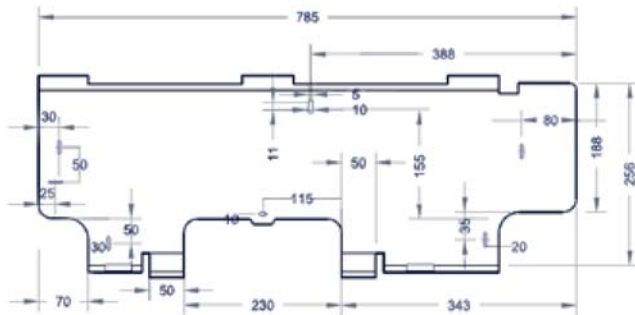
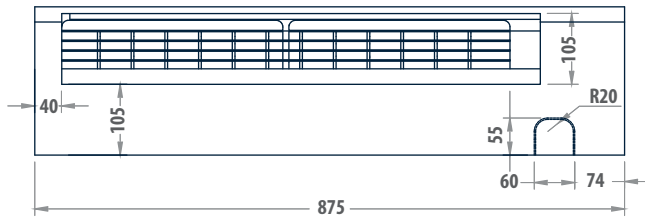
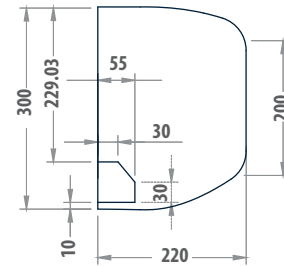
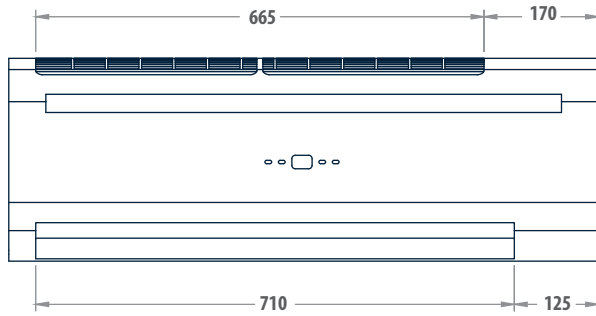

FM		22 / 23	32 / 33	42 / 43
Water connections	"	1/2	1/2	1/2
Condensate discharge	mm	16	16	16
Weight	kg	12	13	14

Hybrid indoor units for air conditioning system

2x1 1 - 3 kW



2x1 by Galletti: evolution in residential air conditioning

Over 50 years of experience in the manufacture of hydronic indoor units for residential and tertiary applications have enabled Galletti to develop an indoor unit of wholly new conception, with the combination of two operating modes in a single unit.

Thanks to an exclusive patented design, 2x1 can function as a heater without the aid of a fan, exploiting instead the principle of natural convection.

In summertime 2x1 offers the advantages of the best fan coil units, cooling, dehumidifying and filtering the air inside the room.

The exclusive patent combines 2 different operating modes in a single unit: 2 different air flow routes inside the unit and 2 distinct heat exchangers make it possible to switch over from natural convection heating to ventilated cooling or heating.

The extra-low speed enables exceptionally quiet operation and high performance.



Supervision
ERGO



2 pipes
systems



4 pipes
systems



Vertical
installation



Centrifugal
fan

PLUS

- » Possibility of operation in natural convection and forced convection modes
- » Cabinet with a refined design
- » 5 levels of thermal emission: 4-speed motor and natural convection
- » Microswitch on exit air flap
- » Reversible water connections
- » Standard configuration for both 2- and 4-pipe systems



AVAILABLE VERSIONS



2 pipes systems

In applications with 2-pipe systems, the configuration requires the 2 exchangers to be connected in series.



4 pipes systems

In 4-pipe systems the exchanger for natural convection is connected to the heating circuit, whilst the exchanger for forced convection is connected to the cooling circuit.

MAIN COMPONENTS

Cabinet with a refined design

RAL9010 colour, front panel made of sheet steel. Side panels and an upper grille with covers on either side manufactured from UV-stabilised ABS to maintain the colour intact over time. The upper grille consists of a flap and adjustable louvers.



Flap

In the wintertime convection heating mode, the flap permits flow through the exchanger by natural convection.



Heat exchangers

2x1 incorporates 2 heat exchangers for 2 distinct operating modes:

- thermo-convector coil made of copper tubing and aluminium fins, where the wide fin spacing optimizes the chimney effect in natural convection.
- fan coil exchanger, made up of copper tubing and high-efficiency aluminium fins submitted to a hydrophilic surface treatment.

Fan assembly

Including centrifugal fans with staggered airfoil-shaped blades, manufactured from anti-static ABS. Four-speed electrical motor, mounted on vibration damping couplings, directly connected to the fans, with permanently activated capacitor and winding thermal protection.



Air filter

Honey-comb polypropylene washable air filter, mounted on a galvanised sheet frame protected by a net, easily removable for maintenance operations.

OPERATING MODE

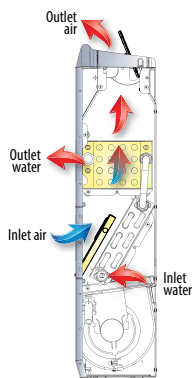

Heating
Static convector mode
Natural convection

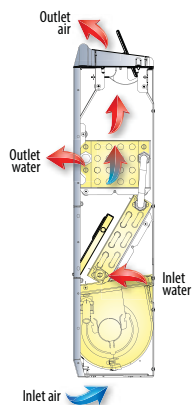

Heating
Static convector mode
Extra low speed

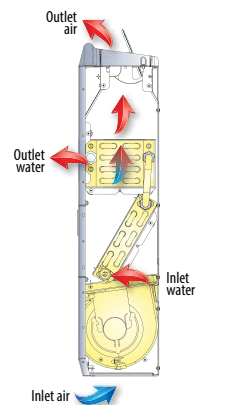

Heating
Fan coil mode
Low, medium and high speed

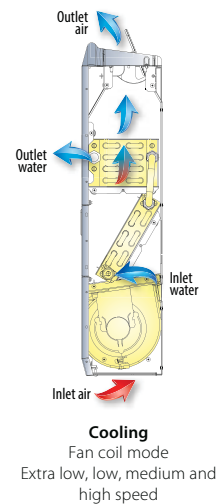

Cooling
Fan coil mode
Extra low, low, medium and high speed

ACCESSORIES

Electromechanical control panels		BVK	Auxiliary water drip tray for vertical installation fan coil units
CBK	On-board 4-speed switch for 2x1	Base and enclosure elements	
Electronic microprocessor control panels with display		ZK	Pair of base and enclosure elements for 2x1
DIST	MY COMFORT controller spacer for wall mounting	Rear covering panels	
EVOBOARD	Circuit board for EVO control	PVK	Rear painted panel for 2x1
EVODISP	User interface with display for EVO controller	Valves	
KB2X1E	MY COMFORT on-board installation KIT for 2X1	V2VDF+STD	2-way valves, ON/OFF or MODULATING actuator, 230 V or 24 V power supply, hydraulic kit, for main and additional heat exchanger
MCBE	MYCOMFORT BASE electronic controller with display	V2VSTD	2-way valve, ON/OFF or MODULATING actuator, 230 V or 24 V power supply, hydraulic kit, for main heat exchanger
MCLE	Microprocessor control with display MY COMFORT LARGE	V3VDF	3-way valves, ON/OFF or MODULATING actuator, 230 V or 24 V power supply, hydraulic kit, for additional heat exchanger
MCME	MYCOMFORT MEDIUM electronic controller with display	V3VSTD	2-way valves, ON/OFF or MODULATING actuator, 230 V or 24 V power supply, hydraulic kit, for main heat exchanger
MCSUE	Humidity sensor for MY COMFORT (medium e large), EVO		
MCSWE	Water sensor for MYCOMFORT, EVO, LED 503 controllers		
Auxiliary water drip trays, insulating shell, condensate drainage pump			

RATED TECHNICAL DATA

2X1			14					24				
Speed			min	med	max	supermin	convection	min	med	max	supermin	convection
Total cooling capacity	(1)	kW	0,77	0,90	1,17	0,62	-	0,82	1,13	1,62	0,65	-
Sensible cooling capacity	(1)	kW	0,60	0,70	0,89	0,49	-	0,62	0,86	1,21	0,45	-
Total cooling capacity	(2)	kW	0,66	0,77	1,00	0,52	-	0,68	0,96	1,40	0,54	-
Sensible cooling capacity	(2)	kW	0,59	0,68	0,87	0,48	-	0,61	0,84	1,18	0,44	-
Water flow	(1)	l/h	133	154	200	107	-	141	193	278	112	-
Water pressure drop	(1)	kPa	2	3	5	2	-	2	3	5	1	-
Heating capacity	(3)	kW	1,86	2,24	2,89	1,65	0,93	2,30	2,84	3,53	1,95	1,30
Water flow	(3)	l/h	164	197	254	145	80	202	250	310	171	112
Water pressure drop	(3)	kPa	3	4	6	2	1	3	5	7	2	1
Rated air flow		m ³ /h	115	135	170	100	-	135	170	225	110	-
Power input		W	12	17	23	11	-	14	20	27	12	-
Total sound power level		dB(A)	29	34	40	27	-	33	37	43	31	-

2X1			34					44				
Speed			min	med	max	supermin	convection	min	med	max	supermin	convection
Total cooling capacity	(1)	kW	1,48	1,82	2,37	1,02	-	1,82	2,17	3,13	1,28	-
Sensible cooling capacity	(1)	kW	1,10	1,35	1,77	0,79	-	1,35	1,62	2,31	0,98	-
Total cooling capacity	(2)	kW	1,28	1,57	2,03	0,86	-	1,57	1,86	2,71	1,08	-
Sensible cooling capacity	(2)	kW	1,08	1,32	1,73	0,77	-	1,33	1,59	2,27	0,96	-
Water flow	(1)	l/h	254	312	407	174	-	312	372	538	220	-
Water pressure drop	(1)	kPa	6	9	14	3	-	8	10	20	4	-
Heating capacity	(3)	kW	3,37	4,13	5,10	2,74	1,49	4,13	5,00	5,89	3,34	1,49
Water flow	(3)	l/h	296	363	449	241	128	363	439	518	294	128
Water pressure drop	(3)	kPa	6	9	13	4	1	9	13	17	6	1
Rated air flow		m ³ /h	200	250	340	160	-	250	310	420	200	-
Power input		W	23	28	37	22	-	25	31	42	22	-
Total sound power level		dB(A)	34	39	46	32	-	34	40	47	33	-

(1) Water temperature 7°C / 12°C, air temperature dry bulb 27°C, wet bulb 19°C (47% relative humidity)

(2) According to EN1397:2015

(3) Water temperature 75°C / 65°C, air temperature 20°C

Power supply 230-1-50 (V-ph-Hz)

DIMENSIONAL DRAWINGS

2x1

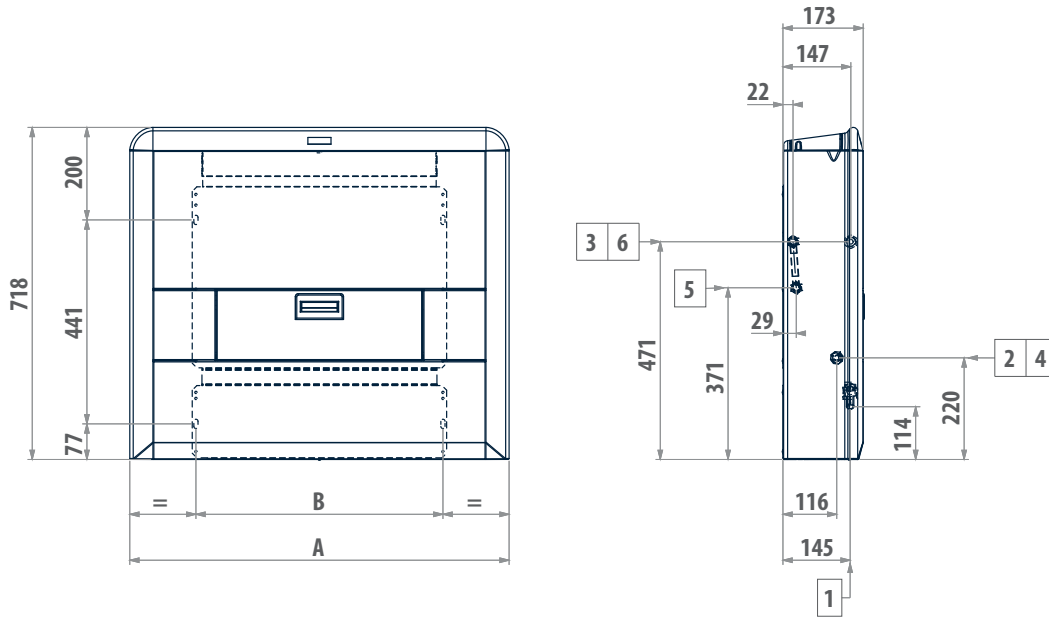

LEGEND

1	Condensate discharge \varnothing 17 mm
2	Water inlet, 2-pipe systems \varnothing 1/2" female gas
3	Water outlet, 2-pipe systems \varnothing 1/2" female gas
4	Cooling circuit water inlet, 4-pipe systems \varnothing 1/2" female gas
5	Cooling circuit water outlet, 4-pipe systems \varnothing 1/2" female gas
6	Heating circuit water connections \varnothing 1/2" female gas

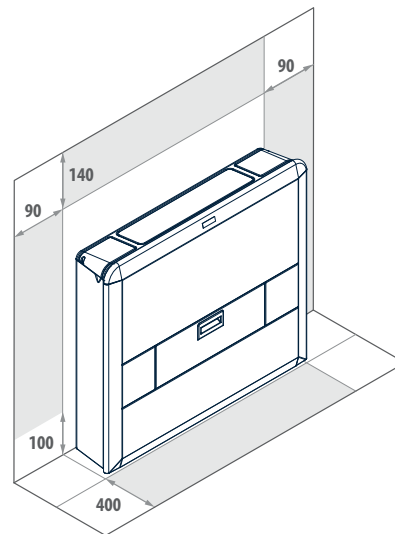

2x1	A mm	B mm	 kg
14	820	534	21
24	990	704	25
34 - 44	1160	874	29

Hydronic indoor unit operating with natural convection

KAIMAN 1 - 2 kW



2 pipes systems

Vertical installation

Galletti's innovative indoor unit that revives the tradition of convective heating

Thanks to over 50 years of experience and new technologies in the production of heat exchangers, it has been possible to design a product in line with the new types of systems, which exploits the principle of the natural convection of air and makes it possible to heat a room faster than with traditional radiators.

The correct temperature of the water in the system is also reached extremely quickly thanks to the low quantity of water in the heat exchanger.

The heat exchanger has also been designed to work at low water temperatures, typically produced by condensation boilers or heat pumps.

Therefore, the surface temperature of KAIMAN will never exceed 40 °C, eliminating the risk of burns.

The temperature of the air output by KAIMAN is such as to minimize blackening of the walls above the unit, a phenomenon typical of high temperature indoor units such as radiators.

With KAIMAN the room temperature can be regulated by means of the air outlet flap which, when set in the closed position, stops the heat exchange, interrupting the effect of natural convection.

If required KAIMAN can be fitted with a thermostatic valve that regulates the room temperature.

It is also possible to guarantee a high standard of air quality using an air sanitisation and ionisation system.

PLUS

- » Steel cabinet / ABS
- » Reversible water connections
- » Heating with low water temperatures
- » Incorporable ioniser
- » Incorporable thermostatic valve



ACCESSORIES

K-1 Thermostatic valve

K-2 Feet so as to hide the tubes if they lead out from the floor.

K-3 Air ionisation system

MAIN COMPONENTS
Cabinet

RAL9010 colour, front panel made of sheet steel. Side panels and an upper grille with covers on either side manufactured from UV-stabilised ABS to maintain the colour intact over time. The upper grille consists of a flap and adjustable louvers.

Indoor unit

Made of galvanized sheet steel and particularly shaped so as to increase natural air convection (chimney effect). High efficiency heat exchanger with copper piping and aluminium fins blocked to pipings by mechanical expansion.

RATED TECHNICAL DATA

KAIMAN			K14	K16	K24	K26	K34	K36
Heating capacity	(1)	kW	1,08	1,22	1,40	1,60	1,73	1,99
Water flow	(1)	l/h	92	105	120	138	149	171
Standard coil - number of rows			4	6	4	6	4	6

(1) Water temperature 75°C / 65°C, air temperature 20°C

DIMENSIONAL DRAWINGS

KAIMAN

Technical drawings showing dimensions for the KAIMAN unit. The front view shows a height of 718 mm and a length of L. The side view shows a depth of 172.5 mm, a top flange height of 118 mm, a base height of 21.8 mm, and a base width of 125 mm. The perspective view shows a depth of 400 mm, a top flange height of 90 mm, a base height of 100 mm, and a top width of 140 mm.

LEGEND

A	Inspection door
B	Flap exit air
C	Inspection door

KAIMAN	L mm	Ø "
K14 - K16	820	1/2
K24 - K26	990	1/2
K34 - K36	1160	1/2

Cassette fan coils

IWC 3 - 9 kW



The IWC range combines solidity and efficiency in a single product

IWC by Galletti stands out for the quality of the components and the care taken in assembly and in the details. The fluid-dynamic optimization at the design stage can be seen in the centrifugal fan with backward-curved blades, statically and dynamically balanced for a correct air flow.

The cassette allows the fan speed to be varied among 4 different steps, thus ensuring excellent modulation in the delivery of power and incredibly low noise levels at the operating speeds. It is moreover equipped with a level sensor and condensate drainage pump already integrated in the unit.

These features make IWC a perfect indoor unit in terms of comfort, reliability and durability like only a product made in Italy can be.

The range is completed by a model with an integrated air sanitisation and ionisation system which is capable of assuring the cleanliness and hygiene of both the unit and the air inside the room. Its aesthetic and constructive features make IWC perfect for installation in any interior with a standard modular false ceiling.

PLUS

- » 4-speed fan drive assembly
- » Robust structure and attractive design
- » Possibility of using a sanitisation system
- » Fresh air drawn directly into the intake compartment
- » Possibility of connecting 4-pipe systems in the absence of glycol to a single-heat exchanger unit by means of a 4 x 2 valves kits



AVAILABLE VERSIONS

IWCT

Unit with one heat exchanger and IR remote control

IWCF IWDF

Unit with one heat exchanger and wired controller
Unit with two heat exchangers and wired controller

MAIN COMPONENTS
Structure

Made from galvanised steel sheet, externally and internally insulated with heat and soundproofing material. The structure houses the main components and is configured for the introduction of air from an external source.

Heat exchanger

High efficiency heat exchanger made with copper piping and aluminium fins blocked to pipings by mechanical expansion, provided with air vent valves.

Front grille

Complete with filter and adjustable air outlet louvers. Different models of panel based on the type of adjustment selected. Possibility of moving the motorized flap with IR remote control. LED indications of operating status and errors.

Air intake and outlet panel

Colour Ral 9001, with preformed air passages made of high density expanded polystyrene and plastic intake port ensuring effective resistance to mechanical wear.

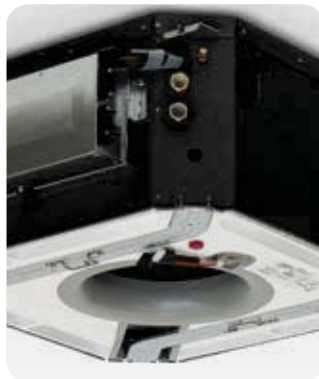
Fan

Centrifugal fan with backward-curving blades with blade profile designed so as to obtain a stable air flow and extremely quiet, efficient operation even at slow fan speeds.

Electric motor

Asynchronous, mounted on 3 vibration-damping supports and directly coupled to the fan. The motor enables operation at 4 different speeds in order to ensure a more precise adjustment.

CONTROL MODE

IR remote control

The IR control offers the possibility of managing the operation of the indoor unit remotely with utmost convenience.

Standard wired controllers

The cassette is configured to be connected to the wall-mounted controllers included in the Galletti range.

ACCESSORIES
Electromechanical control panels

TD4T Wall-mounted speed selector, thermostat and summer/winter selecting switch, for controlling fan and valves

Electronic microprocessor control panels with display

COB Finishing plate for LED 503 controller, RAL9005 black

COG Finishing plate for LED 503 controller, RAL7031 grey

COW Finishing plate for LED 503 controller, RAL9003 white

DIST MY COMFORT controller spacer for wall mounting

EVOBOARD Circuit board for EVO control

EVODISP User interface with display for EVO controller

LED503 Recessed wall-mounted electronic display controller LED 503

MCBE MYCOMFORT BASE electronic controller with display

MCLE Microprocessor control with display MY COMFORT LARGE

MCME MYCOMFORT MEDIUM electronic controller with display

MCSUE Humidity sensor for MY COMFORT (medium e large), EVO

MCSWE Water sensor for MYCOMFORT, EVO, LED 503 controllers

Electronic microprocessor control panels

TED 2T Electronic controller for AC fan control and one ON/OFF 230 V valve

TED 4T Electronic controller for AC fan control and two ON/OFF 230 V valves

TED SWA Water temperature sensor for TED controls

Power interface and regulating louver controllers

KP Power interface for connecting in parallel up to 4 fun coil units to the one controller

Valves

4X2-IWC Kit 4x2 way valve, ON/OFF or MODULATING actuator, 230 V or 24 V power supply, hydraulic kit, for model with 1 heat exchanger

V2-IWC 2-way valve, ON/OFF or MODULATING actuator, 230 V or 24 V power supply, hydraulic kit, for model with 1 or 2 heat exchangers

V3-IWC 3-way valve, ON/OFF or MODULATING actuator, 230 V or 24 V power supply, hydraulic kit, for model with 1 or 2 heat exchangers

RATED TECHNICAL DATA

IWC			32				42				52			
Speed			1	2	3	4	1	2	3	4	1	2	3	4
Total cooling capacity	(1)	kW	1,24	2,15	2,35	2,60	1,70	3,50	4,00	4,60	2,47	3,80	4,42	5,06
Sensible cooling capacity	(1)	kW	0,91	1,78	2,00	2,23	1,16	2,63	3,05	3,56	1,84	2,97	3,51	4,04
Total cooling capacity	(2)(E)	kW	1,22	2,11	2,30	2,54	1,68	3,44	3,93	4,51	2,44	3,73	4,34	4,96
Sensible cooling capacity	(2)(E)	kW	0,89	1,74	1,95	2,17	1,14	2,57	2,98	3,47	1,81	2,90	3,42	3,94
FCEER class	(E)		E				D				E			
Water flow	(1)	l/h	212	368	404	445	292	600	686	788	423	653	758	869
Water pressure drop	(1)(E)	kPa	3	8	9	11	3	11	14	17	7	14	18	23
Heating capacity	(3)(E)	kW	1,54	2,83	3,11	3,49	1,87	4,35	4,85	5,70	3,35	5,33	6,14	6,75
Water pressure drop	(3)(E)	kPa	3	7	8	10	3	10	13	17	6	14	18	23
Heating capacity	(4)(E)	kW	1,29	2,39	2,63	2,96	1,53	3,63	4,04	4,77	2,83	4,52	5,20	5,69
FCCOP class	(E)		E				D				D			
Water flow	(4)	l/h	224	415	457	514	267	632	702	829	492	787	905	990
Water pressure drop	(4)(E)	kPa	3	9	11	13	3	12	14	19	9	20	25	29
Rated air flow		m ³ /h	180	400	460	520	200	530	630	750	370	630	760	880
Power input	(E)	W	17	40	50	60	20	60	70	90	26	71	85	98
Total sound power level	(E)	dB(A)	30	41	44	46	32	48	51	55	41	53	57	61

IWC			62				82			
Speed			1	2	3	4	1	2	3	4
Total cooling capacity	(1)	kW	4,20	5,00	5,42	6,00	5,50	6,50	8,00	9,10
Sensible cooling capacity	(1)	kW	3,14	3,70	3,99	4,40	4,11	5,08	6,10	6,84
Total cooling capacity	(2)(E)	kW	4,12	4,91	5,32	5,88	5,42	6,40	7,88	8,96
Sensible cooling capacity	(2)(E)	kW	3,06	3,61	3,89	4,28	4,03	4,98	5,98	6,70
FCEER class	(E)		E				D			
Water flow	(1)	l/h	721	859	930	1031	944	1116	1372	1561
Water pressure drop	(1)(E)	kPa	16	22	25	30	21	28	41	51
Heating capacity	(3)(E)	kW	5,40	6,40	7,10	7,70	6,28	8,52	9,42	10,2
Water pressure drop	(3)(E)	kPa	16	21	25	30	20	27	39	48
Heating capacity	(4)(E)	kW	4,55	5,38	5,99	6,47	5,20	7,16	7,83	8,42
FCCOP class	(E)		D				D			
Water flow	(4)	l/h	790	936	1041	1126	903	1246	1361	1464
Water pressure drop	(4)(E)	kPa	19	25	31	35	19	33	39	44
Rated air flow		m ³ /h	850	1060	1160	1300	830	1090	1270	1400
Power input	(E)	W	80	90	100	120	80	100	120	140
Total sound power level	(E)	dB(A)	43	48	49	51	37	46	50	53

(1) Water temperature 7°C / 12°C, air temperature dry bulb 27°C, wet bulb 19°C (47% relative humidity)

(2) According to EN1397:2015

(3) Inlet water temperature 50°C, water flow rate same as in cooling mode, air temperature 20°C

(4) Water temperature 45°C / 40°C, air temperature 20°C

(E) EUROVENT certified data

Power supply 230-1-50 (V-ph-Hz)

RATED TECHNICAL DATA

IWC			34				44			
Speed			1	2	3	4	1	2	3	4
Total cooling capacity	(1)	kW	1,10	1,72	1,88	2,05	1,58	2,88	3,28	3,76
Sensible cooling capacity	(1)	kW	0,83	1,51	1,66	1,82	1,10	2,27	2,60	3,00
Total cooling capacity	(2)(E)	kW	1,08	1,68	1,83	1,99	1,56	2,82	3,21	3,67
Sensible cooling capacity	(2)(E)	kW	0,81	1,47	1,61	1,76	1,08	2,21	2,53	2,91
FCEER class	(E)		E							
Water flow	(1)	l/h	189	295	323	351	272	494	562	645
Water pressure drop	(1)(E)	kPa	4	8	9	11	4	11	13	17
Heating capacity DF	(3)(E)	kW	0,96	1,56	1,71	1,93	1,27	2,50	2,74	3,28
FCCOP class	(E)		E							
Water flow DF	(3)	l/h	85	136	150	169	111	219	240	287
Water pressure drop DF	(3)(E)	kPa	8	20	23	29	5	18	21	28
Rated air flow		m ³ /h	180	400	460	520	200	530	630	750
Power input	(E)	W	17	40	50	69	20	60	70	90
Total sound power level	(E)	dB(A)	25	36	39	41	27	43	46	50

(1) Water temperature 7°C / 12°C, air temperature dry bulb 27°C, wet bulb 19°C (47% relative humidity)

(2) According to EN1397:2015

(3) Water temperature 65°C / 55°C, air temperature 20°C

(E) EUROVENT certified data

Power supply 230-1-50 (V-ph-Hz)

DIMENSIONAL DRAWINGS

IWC 032 - 042 - 052 - 034 - 044

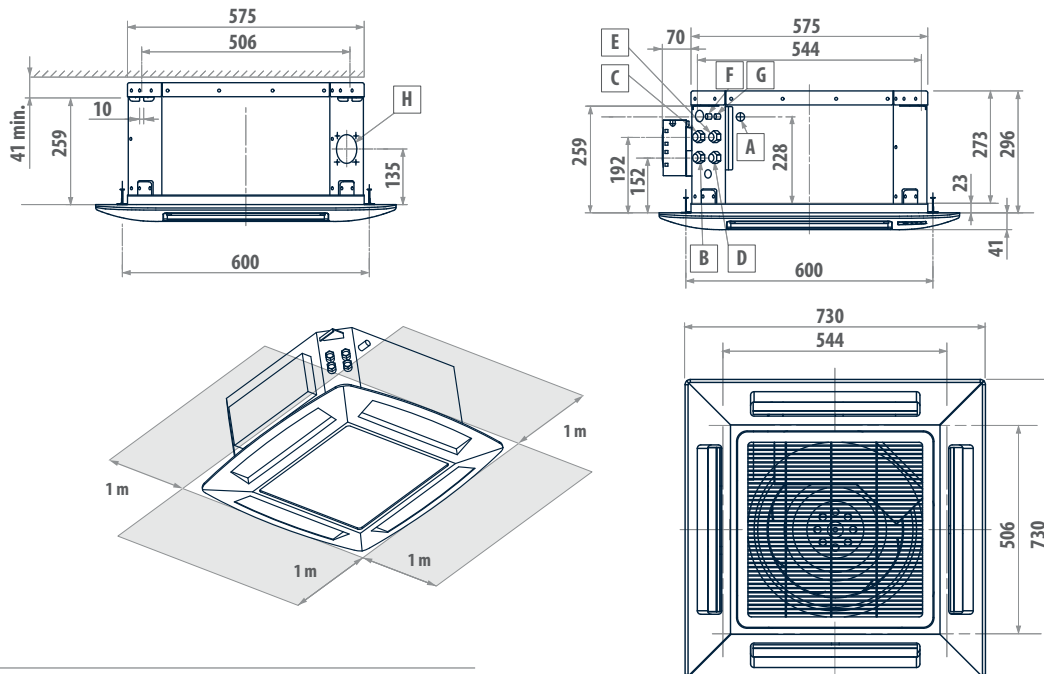

LEGEND

A	Condensate hole: \varnothing external 18 mm
B	Main heat exchanger water inlet \varnothing 1/2" female gas
C	Main heat exchanger water outlet \varnothing 1/2" female gas
D	Additional heat exchanger water inlet \varnothing 1/2" female gas
E	Additional heat exchanger water outlet \varnothing 1/2" female gas
F	Main heat exchanger air vent
G	Additional heat exchanger air vent
H	External air intake \varnothing 70 mm

IWC	kg
32	18 + 2,50
42 - 52	20 + 2,50

DIMENSIONAL DRAWINGS

IWC 062

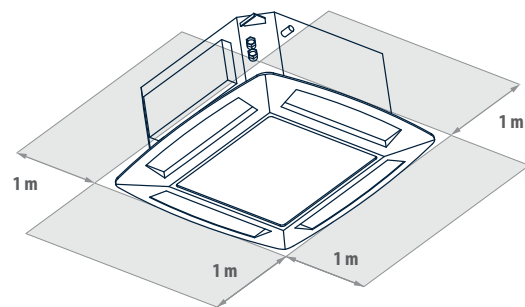
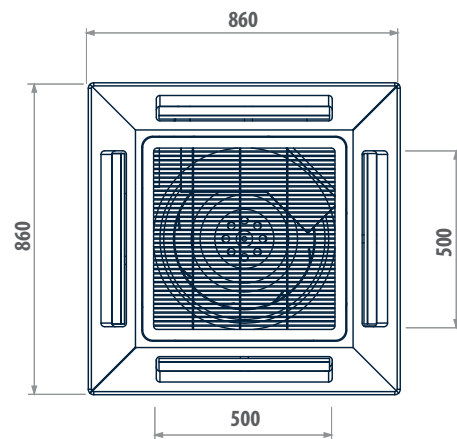
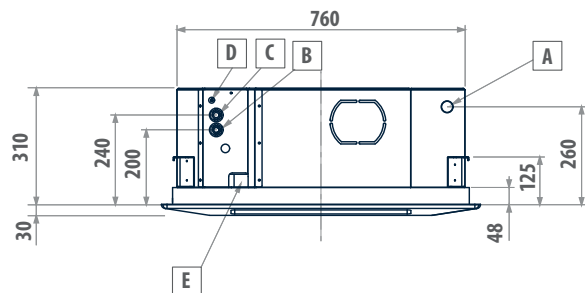
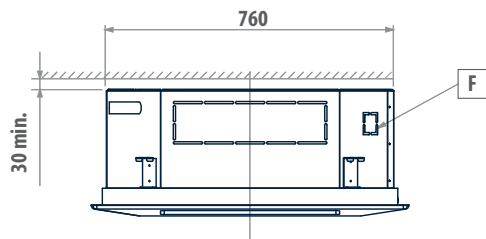

LEGEND

A	Condensate hole: \varnothing external 32 mm
B	Water inlet \varnothing 3/4" female gas
C	Water outlet \varnothing 3/4" female gas
D	Heat exchanger air vent
E	Electrical cable passage
F	Fresh air intake: 60 x 55 mm

IWC



kg

62

23 + 5

DIMENSIONAL DRAWINGS

IWC 082 - 102

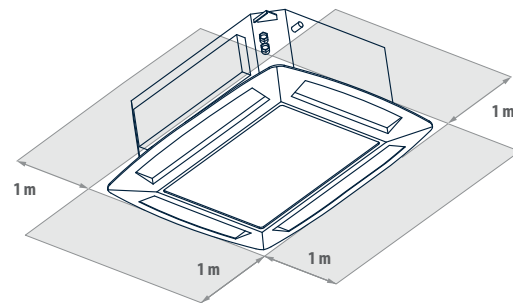
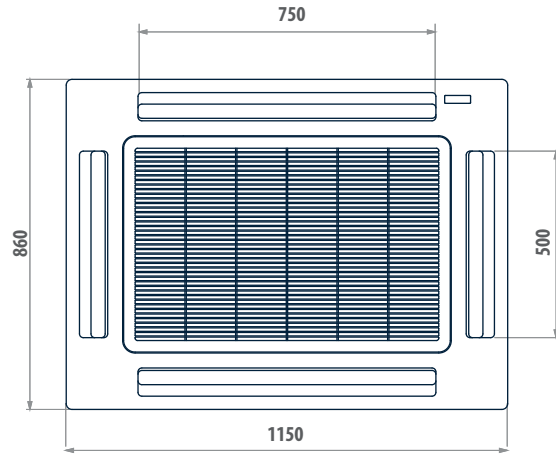
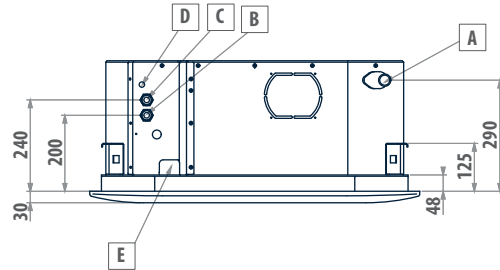
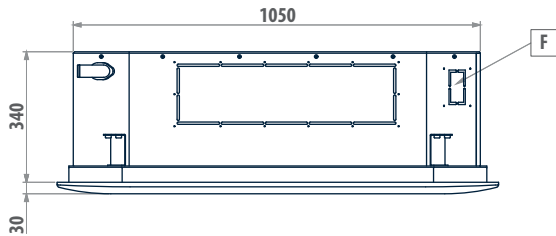

LEGEND

- | | |
|----------|---|
| A | Condensate hole: \varnothing external 32 mm |
| B | Water inlet \varnothing 3/4" female gas |
| C | Water outlet \varnothing 3/4" female gas |
| D | Heat exchanger air vent |
| E | Electrical cable passage |
| F | Fresh air intake: 60 x 55 mm |

SIZE 102 AVAILABLE ONLY ON INVERTER VERSION

IWC	kg
82 - 102	29 + 7

Cassette fan coils with BLDC motor

IWC i 3 - 10 kW



PLUS

- » Permanent magnet BLDC motor for precise, continuous control
- » Electrical input reduced by more than one half compared to the ON/OFF version
- » Robust structure and attractive design
- » Temperature reading via the remote control
- » Control of perceived temperature
- » Serial communication networks

The new hydronic cassette unit with modulating fan control for a perfect mix of comfort and precision

In the new water cassette with inverter technology, Galletti combines ten years of know-how in comfort air conditioning with the technology of brushless motors, offering a series of adjustment logics capable of adapting the product to every need.

The modulating control of the fan speed ensures a continuous adaptation of the delivered power to the thermal load without disturbing the user with abrupt changes in the noise emitted.

The extraordinary technology of the permanent magnet BLDC motors offers an additional advantage over the solution with asynchronous motors, reducing electricity consumption by up to 75%.

The adjustment logic offers the user a control based not only on temperature but also on the humidity present in the room, with an intelligent analysis of the temperature actually perceived by the user.

Galletti responds to growing demands for precision, quiet operation, energy savings and aesthetic value with IWC i, a unit with advanced technological features developed with the traditional care that distinguishes the company's products.

The unit can be controlled by means of the remote control, optionally connected with the kit provided.



AVAILABLE VERSIONS

- IWCi** Unit with 1 heat exchanger
- IWCi DF** Unit with 2 heat exchangers

MAIN COMPONENTS
Structure

Made from galvanised steel sheet, externally and internally insulated with heat and soundproofing material. The structure houses the main components and is configured for the introduction of air from an external source.

Heat exchanger

High efficiency heat exchanger made with copper piping and aluminium fins blocked to pipings by mechanical expansion, provided with air vent valves.

Front grille

Complete with filter and adjustable air outlet louvers. Possibility of moving the motorized flap with IR remote control. LED indications of operating status and errors.

Fan

Centrifugal fan with backward-curving blades with blade profile designed so as to obtain a stable air flow and extremely quiet, efficient operation even at slow fan speeds.

Air intake and outlet panel

Colour Ral 9001, with preformed air passages made of high density expanded polystyrene and plastic intake port ensuring effective resistance to mechanical wear.

Air filter

Honey-comb polypropylene washable air filter, mounted on a galvanised sheet frame protected by a net, easily removable for maintenance operations.

Electric motor

Permanent magnet controlled by dedicated electronics. This technology guarantees energy savings, compact construction, precision, a reduction in electromagnetic disturbance and a longer working life of the unit.

CONTROL MODE

Remote control

IR remote control with additional probe readings to ensure precise comfort in every part of the room. A special kit enables communication via a wired connection.

Control panel

The hydronic cassettes can moreover be controlled by means of all controllers that have a 0 – 10 V analogue output for controlling the fan speed and a voltage-free contact for setting the operating mode.

ACCESSORIES
Electronic microprocessor control panels with display

DIST	MY COMFORT controller spacer for wall mounting
EVOBOARD	Circuit board for EVO control
EVO DISP	User interface with display for EVO controller
KF	Wiring kit for connecting the remote control to the cassette
MCLE	Microprocessor control with display MY COMFORT LARGE
MCSUE	Humidity sensor for MY COMFORT (medium e large), EVO
MCSWE	Water sensor for MYCOMFORT, EVO, LED 503 controllers

RC	Infrared remote control or wired connection
Valves	
4X2-IWC	Kit 4x2 way valve, ON/OFF or MODULATING actuator, 230 V or 24 V power supply, hydraulic kit, for model with 1 heat exchanger
V2-IWC	2-way valve, ON/OFF or MODULATING actuator, 230 V or 24 V power supply, hydraulic kit, for model with 1 or 2 heat exchangers
V3-IWC	3-way valve, ON/OFF or MODULATING actuator, 230 V or 24 V power supply, hydraulic kit, for model with 1 or 2 heat exchangers

RATED TECHNICAL DATA

IWC i			32				42				52			
Speed			1	2	3	4	1	2	3	4	1	2	3	4
Total cooling capacity	(1)	kW	1,24	2,15	2,35	2,60	1,70	3,50	4,00	4,60	2,47	3,80	4,42	5,06
Sensible cooling capacity	(1)	kW	0,91	1,78	2,00	2,23	1,16	2,63	3,05	3,56	1,84	2,97	3,51	4,04
Total cooling capacity	(2)(E)	kW	1,24	2,14	2,34	2,59	1,69	3,48	3,97	4,56	2,46	3,77	4,38	5,01
Sensible cooling capacity	(2)(E)	kW	0,91	1,77	1,99	2,21	1,15	2,61	3,02	3,52	1,83	2,94	3,47	3,99
FCEER class	(E)		A				B				C			
Water flow	(1)	l/h	212	368	404	445	292	600	686	788	423	653	758	869
Water pressure drop	(1)(E)	kPa	3	8	9	11	3	11	14	17	7	14	18	23
Heating capacity	(3)(E)	kW	1,54	2,83	3,11	3,49	1,87	4,35	4,85	5,70	3,35	5,33	6,14	6,75
Water pressure drop	(3)(E)	kPa	3	7	8	10	3	10	13	17	6	14	18	23
Heating capacity	(4)(E)	kW	1,29	2,39	2,63	2,96	1,53	3,63	4,04	4,77	2,83	4,52	5,20	5,69
FCCOP class	(E)		A				B				C			
Water flow	(4)	l/h	224	415	457	514	267	632	702	829	492	787	905	990
Water pressure drop	(4)(E)	kPa	3	9	11	13	3	12	14	19	9	20	25	29
Rated air flow		m ³ /h	180	400	460	520	200	530	630	750	370	630	760	880
Power input	(E)	W	5	10	13	15	8	24	28	36	12	34	40	47
Total sound power level	(E)	dB(A)	30	41	44	46	32	48	51	55	41	53	57	61

IWC i			62				82				102			
Speed			1	2	3	4	1	2	3	4	1	2	3	4
Total cooling capacity	(1)	kW	4,20	5,00	5,42	6,00	5,50	6,50	8,00	9,10	6,24	8,09	8,90	9,92
Sensible cooling capacity	(1)	kW	3,14	3,70	3,99	4,40	4,11	5,08	6,10	6,84	4,69	6,17	6,87	7,71
Total cooling capacity	(2)(E)	kW	4,19	4,98	5,39	5,96	5,49	6,48	7,96	9,04	6,22	8,05	8,86	9,86
Sensible cooling capacity	(2)(E)	kW	3,13	3,68	3,97	4,36	4,10	5,06	6,06	6,79	4,67	6,13	6,83	7,65
FCEER class	(E)		A											
Water flow	(1)	l/h	721	859	930	1031	944	1116	1372	1561	1069	1389	1529	1702
Water pressure drop	(1)(E)	kPa	16	22	25	30	21	28	41	51	27	42	50	60
Heating capacity	(3)(E)	kW	5,40	6,40	7,10	7,70	6,28	8,52	9,42	10,2	7,34	9,53	10,6	11,7
Water pressure drop	(3)(E)	kPa	16	21	25	30	20	27	39	48	26	42	49	60
Heating capacity	(4)(E)	kW	4,55	5,38	5,99	6,47	5,20	7,16	7,83	8,42	6,10	7,92	8,82	9,71
FCCOP class	(E)		A				A				B			
Water flow	(4)	l/h	790	936	1041	1126	903	1246	1361	1464	1061	1377	1533	1689
Water pressure drop	(4)(E)	kPa	19	25	31	35	19	33	39	44	27	42	51	60
Rated air flow		m ³ /h	850	1060	1160	1300	830	1090	1270	1400	1200	1700	1980	2300
Power input	(E)	W	8	20	25	41	10	22	41	55	18	36	43	64
Total sound power level	(E)	dB(A)	43	48	49	51	37	46	50	53	43	49	53	57

(1) Water temperature 7°C / 12°C, air temperature dry bulb 27°C, wet bulb 19°C (47% relative humidity)

(2) According to EN1397:2015

(3) Inlet water temperature 50°C, water flow rate same as in cooling mode, air temperature 20°C

(4) Water temperature 45°C / 40°C, air temperature 20°C

(E) EUROVENT certified data

Power supply 230-1-50 (V-ph-Hz)

NOTE: The dimensional drawings of the IWC i inverter units are the same of the IWC ON/OFF version. They are reported from page 83

RATED TECHNICAL DATA

IWC i			34				44				
Speed			1	2	3	4	1	2	3	4	
Total cooling capacity	(1)	kW	1,10	1,72	1,88	2,05	1,58	2,88	3,28	3,76	
Sensible cooling capacity	(1)	kW	0,83	1,51	1,66	1,82	1,10	2,27	2,60	3,00	
Total cooling capacity	(2)(E)	kW	1,10	1,71	1,87	2,03	1,57	2,86	3,25	3,72	
Sensible cooling capacity	(2)(E)	kW	0,82	1,50	1,65	1,81	1,09	2,25	2,57	2,96	
FCEER class	(E)		B				C				
Water flow	(1)	l/h	189	295	323	351	272	494	562	645	
Water pressure drop	(1)(E)	kPa	4	8	9	11	4	11	13	17	
Heating capacity DF	(3)(E)	kW	0,96	1,56	1,71	2,00	1,27	2,50	2,74	3,00	
FCCOP class	(E)		C								
Water flow DF	(3)	l/h	85	136	150	169	111	219	240	287	
Water pressure drop DF	(3)(E)	kPa	8	20	23	29	5	18	21	28	
Rated air flow		m ³ /h	180	400	460	520	200	530	630	750	
Power input	(E)	W	5	10	13	15	8	24	28	36	
Total sound power level	(E)	dB(A)	30	41	44	46	32	48	51	55	

(1) Water temperature 7°C / 12°C, air temperature dry bulb 27°C, wet bulb 19°C (47% relative humidity)

(2) According to EN1397:2015

(3) Water temperature 65°C / 55°C, air temperature 20°C

(E) EUROVENT certified data

Power supply 230-1-50 (V-ph-Hz)

NOTE: The dimensional drawings of the IWC i inverter units are the same of the IWC ON/OFF version. They are reported from page 83

Medium available head duct units

DUCTIMAX 2 - 8 kW



Performance and compactness in recessed ceiling installations

The DUCTIMAX ducted unit has been conceived for air conditioning interiors where the installation of high-performance medium head units with reduced overall dimensions is required. The range features 12 models with air flows of from 300 to 1200 m³/h. The heat exchanger enables DUCTIMAX to be used under a whole variety of operating conditions. The weight-bearing structure in fact houses a 3- or 4-row exchanger which can be combined with an additional 1 or 2-rows exchanger (on request) for exceptional performance even with low temperature differentials. The heat exchangers can be optimized for centralized applications such as district cooling. DUCTIMAX is designed for horizontal ceiling installation. The main condensate drip tray is situated inside the structure of the unit and is at a positive pressure relative to the drain outlet to facilitate condensate drainage.

A wide range of wall-mounted controllers is available, including controllers of an electromechanical type and microprocessor controllers with display. The use of MYCOMFORT MEDIUM and MYCOMFORT LARGE or EVO enables DUCTIMAX to be connected to ERGO.

Heating elements complete with safety devices are available to supplement the hydronic system.

The action of the G3 air filter can be combined with an air ionisation system.

PLUS

- » Multi speed motor
- » Heat exchanger up to 4 rows
- » Reversible water connections
- » ABS centrifugal fans
- » Can be integrated into ERGO



The bearing structure allows to combine a large range of accessories in suction and air delivery in order to obtain the optimized unit configuration.

AVAILABLE VERSIONS

DMXXD0LO...A Units for 2 pipes systems
DMXXD0LL...A Unit for 4-pipe systems equipped with an additional 1-row exchanger for the hot water circuit

DMXXD0LM...A Unit for 4-pipe systems equipped with an additional 2-row exchanger for the hot water circuit
(On request)

Available on request air decontamination system installed on special plenum

MAIN COMPONENTS
Structure

Built from galvanised steel sheet, heat and sound insulated by means of Class 1 self-extinguishing panels. Reduced height to facilitate installation in a horizontal position in a false ceiling. The structure incorporates a drip tray and condensate drain outlet.

Heat exchanger

High efficiency 3 and 4 rows heat exchanger made with copper piping and aluminium fins blocked to pipings by mechanical expansion, provided with brass manifolds and air vent valve. The heat exchanger usually comes with water connections mounted on the left, but it can be turned by 180°. High-efficiency heat exchangers optimized for district cooling applications are available on request.

Electric motor

Single-phase asynchronous multi-speed electric motor with permanently connected capacitor and thermal protector, mounted on vibration-damping supports.

Fans

Double suction centrifugal fans made with ABS or aluminium, with statically and dynamically balanced forward-curving blades, directly coupled to the electric motor.

Air filter

Washable air filter, made of acrylic fibre, filtration class G2 or G3, applied on the air intake; may be pulled out from below.

ACCESSORIES
Electromechanical control panels

CD	Recess wall-mounted speed switch
CDE	Wall mounted speed selector
TA	Wall-mounted room thermostat
TA2	Electromechanical room thermostat with summer/winter selection
TC	Thermostat for minimum water temperature in heating mode (42 °C)
TD	Wall mounted control with speed selector, thermostat and summer-winter selector
TD4T	Wall-mounted speed selector, thermostat and summer/winter selecting switch, for controlling fan and valves
TDC	Wall mounted control with speed selector and thermostat

Electronic microprocessor control panels with display

COB	Finishing plate for LED 503 controller, RAL9005 black
COG	Finishing plate for LED 503 controller, RAL7031 grey
COW	Finishing plate for LED 503 controller, RAL9003 white
DIST	MY COMFORT controller spacer for wall mounting
EVOBOARD	Circuit board for EVO control
EVO DISP	User interface with display for EVO controller
LED503	Recessed wall-mounted electronic display controller LED 503
MCBE	MYCOMFORT BASE electronic controller with display
MCLE	Microprocessor control with display MY COMFORT LARGE
MCME	MYCOMFORT MEDIUM electronic controller with display
MCSUE	Humidity sensor for MY COMFORT (medium e large), EVO
MCSWE	Water sensor for MYCOMFORT, EVO, LED 503 controllers

Electronic microprocessor control panels

TED 2T	Electronic controller for AC fan control and one ON/OFF 230 V valve
TED 4T	Electronic controller for AC fan control and two ON/OFF 230 V valves
TED SWA	Water temperature sensor for TED controls

Power interface and regulating lower controllers

KP	Power interface for connecting in parallel up to 4 fan coil units to the one controller
-----------	---

Electrical heating elements

RE	Heating element with installation kit, relay box and safety devices
-----------	---

Air inlet and outlet grilles

GA	Aluminium air intake grille, with frame
GM	Aluminium air outlet grille with 2-row fins and subframe

Valves

V2VDF+STD	2-way valves, ON/OFF or MODULATING actuator, 230 V or 24 V power supply, hydraulic kit, for main and additional heat exchanger
V2VSTD	2-way valve, ON/OFF or MODULATING actuator, 230 V or 24 V power supply, hydraulic kit, for main heat exchanger
V3VDF	3-way valves, ON/OFF or MODULATING actuator, 230 V or 24 V power supply, hydraulic kit, for additional heat exchanger
V3VSTD	2-way valves, ON/OFF or MODULATING actuator, 230 V or 24 V power supply, hydraulic kit, for main heat exchanger

Plenum, air intake modules, air inlet and outlet connectors

MAFO	Air intake module with G4 air filter
PAF	Intake and delivery plenum, not insulated, with spigot Ø 200 mm
PMA	Intake and delivery plenum, not insulated, with spigot Ø 200 mm
PMAC	Intake and delivery plenum, insulated, with spigot Ø 200 mm
R90	90° uninsulated air inlet/outlet connector
R90C	90° uninsulated air inlet/outlet connector
RD	Straight uninsulated air inlet/outlet connector
RDC	Straight insulated air inlet/outlet connector

Flexible ducts - caps

TFA	Not insulated flexible ducts, Ø 200 mm (6 m length undivisible)
TFM	Insulated flexible ducts, Ø 200 mm (6 m length undivisible)
TP	Plastic cap Ø 200 mm

Air inlet and outlet plenum box

CA	Air Inlet plenum box with double row grille
CAF	Air Inlet plenum box with double row grille 300 x 600 mm and filter G2
CM	Insulated air outlet plenum box with grille

Accessories

KSC	Condensate drainage pump kit
VRC	Auxiliary water drip tray

RATED TECHNICAL DATA

DUCTIMAX			13			14			23			24		
Speed			min	med	max	min	med	max	min	med	max	min	med	max
Rated air flow	(E)	m ³ /h	108	246	276	138	246	276	171	275	341	171	275	341
Available static pressure	(E)	Pa	15	50	63	15	50	63	19	50	77	19	50	77
Power input	(E)	W	24	57	82	24	57	82	34	69	106	34	69	106
Total cooling capacity	(1)	kW	1,12	1,78	1,98	1,18	1,97	2,18	1,30	1,97	2,38	1,39	2,18	2,64
Sensible cooling capacity	(1)	kW	0,77	1,28	1,41	0,80	1,36	1,51	0,92	1,41	1,70	0,96	1,51	1,84
Total cooling capacity	(2)(E)	kW	1,10	1,72	1,90	1,16	1,91	2,10	1,27	1,90	2,27	1,36	2,11	2,53
Sensible cooling capacity	(2)(E)	kW	0,75	1,22	1,33	0,78	1,30	1,43	0,89	1,34	1,59	0,93	1,44	1,73
FCEER class	(E)		D			C			D			D		
Water flow	(1)	l/h	192	306	339	203	338	374	223	339	409	239	374	453
Water pressure drop	(1)(E)	kPa	2	5	6	3	7	8	3	6	8	4	8	12
Heating capacity	(3)(E)	kW	1,32	2,18	2,39	1,37	2,38	2,64	1,60	2,38	2,83	1,69	2,64	3,22
Water pressure drop	(3)(E)	kPa	2	4	5	2	6	7	2	5	6	3	7	10
Heating capacity	(4)(E)	kW	1,04	1,71	1,88	1,14	1,98	2,20	1,33	1,98	2,35	1,41	2,20	2,68
FCCOP class	(E)		C											
Water flow	(4)	l/h	181	297	327	198	345	384	231	345	408	244	382	466
Water pressure drop	(4)(E)	kPa	2	4	5	2	6	7	2	5	7	3	7	10
Standard coil - number of rows			3			4			3			4		
Total sound power level		dB(A)	26	48	52	26	48	52	36	50	58	36	50	58
Inlet + radiated sound power level	(E)	dB(A)	29	46	50	24	46	50	34	48	56	34	48	56
Outlet sound power level	(E)	dB(A)	27	45	49	22	45	49	32	47	55	32	47	55
Heating capacity DF 1R	(5)(E)	kW	1,34	1,93	2,06	1,34	1,93	2,06	1,55	2,06	2,32	1,55	2,06	2,32
Water flow DF 1R	(5)	l/h	117	169	182	117	169	182	136	181	204	136	181	204
Water pressure drop DF 1R	(5)(E)	kPa	1	2	3	1	2	3	2	3	3	2	3	3
Additional coil DF - number of rows			1			1			1			1		

DUCTIMAX			33			34			43			44		
Speed			min	med	max	min	med	max	min	med	max	min	med	max
Rated air flow	(E)	m ³ /h	196	360	402	196	360	402	305	532	652	305	532	652
Available static pressure	(E)	Pa	14	50	63	14	50	63	17	50	76	17	50	76
Power input	(E)	W	34	85	106	34	85	106	76	143	192	76	143	192
Total cooling capacity	(1)	kW	1,47	2,36	2,62	1,60	2,77	3,07	2,00	3,31	3,87	2,37	3,92	4,65
Sensible cooling capacity	(1)	kW	1,05	1,77	1,97	1,10	1,93	2,14	1,50	2,53	3,00	1,65	2,75	3,27
Total cooling capacity	(2)(E)	kW	1,44	2,27	2,51	1,57	2,69	2,96	1,92	3,17	3,68	2,29	3,78	4,46
Sensible cooling capacity	(2)(E)	kW	1,02	1,69	1,86	1,07	1,85	2,03	1,42	2,39	2,81	1,57	2,61	3,08
FCEER class	(E)		D			D			E			D		
Water flow	(1)	l/h	253	405	449	275	476	527	343	568	664	407	673	797
Water pressure drop	(1)(E)	kPa	2	5	5	3	7	9	3	8	11	6	14	18
Heating capacity	(3)(E)	kW	1,88	3,20	3,52	1,92	3,36	3,72	2,78	4,40	5,11	2,90	4,74	5,62
Water pressure drop	(3)(E)	kPa	2	4	4	2	6	7	3	7	9	5	11	15
Heating capacity	(4)(E)	kW	1,57	2,70	2,96	1,59	2,80	3,10	2,35	3,70	4,31	2,41	3,95	4,68
FCCOP class	(E)		C			C			D			D		
Water flow	(4)	l/h	274	470	515	277	488	538	408	644	749	419	687	814
Water pressure drop	(4)(E)	kPa	2	5	6	2	6	8	4	9	11	5	12	16
Standard coil - number of rows			3			4			3			4		
Total sound power level		dB(A)	36	52	58	36	52	58	39	52	60	39	52	60
Inlet + radiated sound power level	(E)	dB(A)	34	50	56	34	50	56	37	50	58	37	50	58
Outlet sound power level	(E)	dB(A)	32	49	55	32	49	55	35	47	56	35	47	56
Heating capacity DF 1R	(5)(E)	kW	2,09	3,09	3,29	2,09	3,09	3,29	2,80	3,82	4,24	2,80	3,82	4,24
Water flow DF 1R	(5)	l/h	183	271	288	183	271	288	245	334	371	245	334	371
Water pressure drop DF 1R	(5)(E)	kPa	2	3	4	2	3	4	3	5	6	3	5	6
Additional coil DF - number of rows			1			1			1			1		

RATED TECHNICAL DATA

DUCTIMAX			53			54			63			64		
Speed			min	med	max	min	med	max	min	med	max	min	med	max
Rated air flow	(E)	m ³ /h	337	687	760	337	687	760	1045	1170	1285	1045	1170	1285
Available static pressure	(E)	Pa	12	50	61	12	50	61	40	50	60	40	50	60
Power input	(E)	W	76	167	192	76	167	192	235	280	332	235	280	332
Total cooling capacity	(1)	kW	2,31	4,39	4,82	2,54	4,95	5,42	6,36	6,98	7,52	7,11	7,81	8,42
Sensible cooling capacity	(1)	kW	1,70	3,26	3,58	1,79	3,50	3,83	4,72	5,19	5,61	5,04	5,54	5,99
Total cooling capacity	(2)(E)	kW	2,23	4,22	4,63	2,46	4,78	5,23	6,13	6,70	7,19	6,88	7,53	8,09
Sensible cooling capacity	(2)(E)	kW	1,62	3,09	3,39	1,71	3,33	3,64	4,49	4,91	5,28	4,80	5,26	5,66
FCEER class	(E)		D											
Water flow	(1)	l/h	397	754	828	436	851	930	1092	1197	1291	1221	1340	1445
Water pressure drop	(1)(E)	kPa	2	7	8	3	10	12	13	16	18	20	23	26
Heating capacity	(3)(E)	kW	3,05	5,66	6,16	3,18	6,04	6,59	7,94	8,65	9,29	8,59	9,40	10,1
Water pressure drop	(3)(E)	kPa	2	6	7	3	8	10	11	13	15	16	19	21
Heating capacity	(4)(E)	kW	2,57	4,75	5,17	2,65	5,03	5,49	6,64	7,23	7,76	7,15	7,84	8,44
FCCOP class	(E)		D											
Water flow	(4)	l/h	446	827	898	462	875	955	1154	1258	1349	1244	1362	1468
Water pressure drop	(4)(E)	kPa	2	7	8	3	9	11	12	14	16	17	20	22
Standard coil - number of rows			3			4			3			4		
Total sound power level		dB(A)	39	55	60	39	55	60	59	62	69	59	62	69
Inlet + radiated sound power level	(E)	dB(A)	37	53	58	37	53	58	57	60	67	57	60	67
Outlet sound power level	(E)	dB(A)	35	51	56	35	51	56	55	58	65	55	58	65
Heating capacity DF 1R	(5)(E)	kW	3,42	5,17	5,45	3,42	5,17	5,45	6,38	6,72	7,00	6,38	6,72	7,00
Water flow DF 1R	(5)	l/h	299	452	477	299	452	477	559	588	613	559	588	613
Water pressure drop DF 1R	(5)(E)	kPa	6	13	14	6	13	14	19	21	22	19	21	22
Additional coil DF - number of rows			1			1			1			1		

- (1) Water temperature 7°C / 12°C, air temperature dry bulb 27°C, wet bulb 19°C (47% relative humidity)
 (2) According to EN1397:2015
 (3) Inlet water temperature 50°C, water flow rate same as in cooling mode, air temperature 20°C
 (4) Water temperature 45°C / 40°C, air temperature 20°C
 (5) Water temperature 65°C / 55°C, air temperature 20°C
 (E) EUROVENT certified data
 Power supply 230-1-50 (V-ph-Hz)

DIMENSIONAL DRAWINGS

DUCTIMAX 1-4

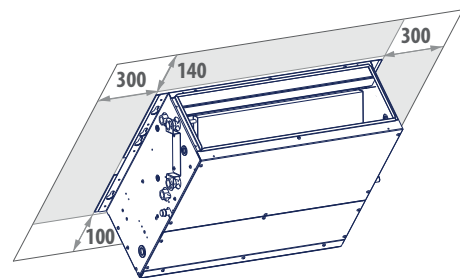
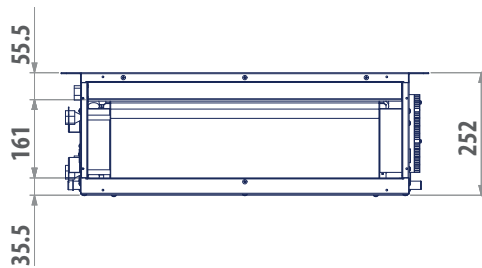
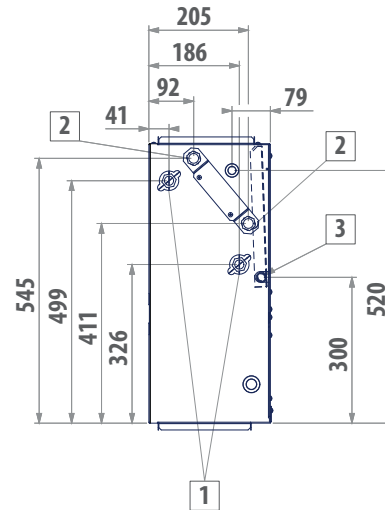
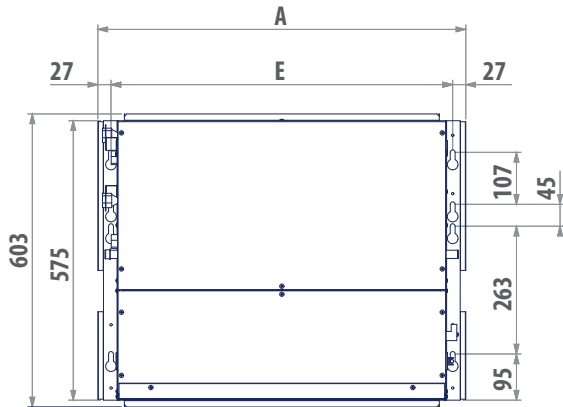
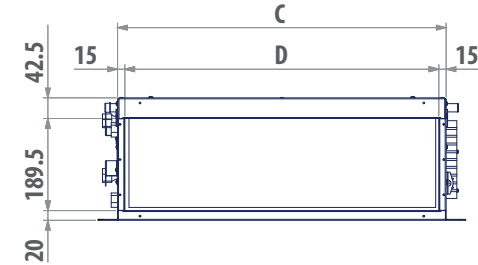

LEGEND

- | | |
|---|---|
| 1 | Water connections standard heat exchanger \varnothing 1/2" female gas |
| 2 | Water connections additional heat exchanger \varnothing 1/2" female gas |
| 3 | Condensate discharge |

DUCTIMAX	13	14	23	24	33	34	43	44
ON/OFF motor	x	x	x	x	x	x	x	x
Inverter-controlled motor	x	x	x	x	x	x	x	x

x = available

DUCTIMAX	A	C	D	E	1	3	
	mm	mm	mm	mm	"	mm	kg
13 - 14	757	677	648	703	1/2	17	19
23 - 24	757	677	648	703	1/2	17	20
33 - 34	967	887	858	913	1/2	17	25
43 - 44	967	887	858	913	1/2	17	28

DIMENSIONAL DRAWINGS

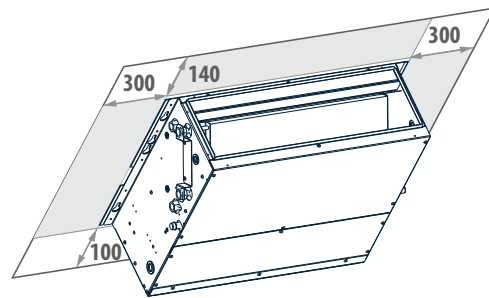
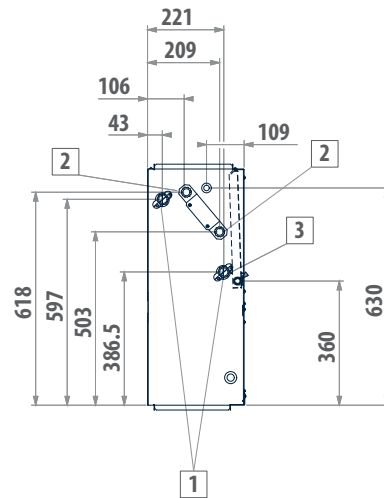
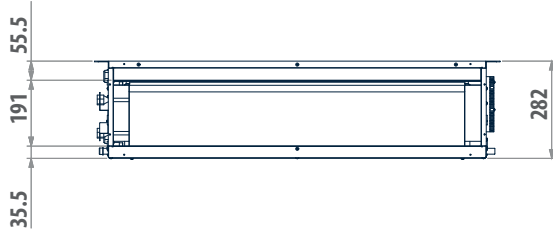
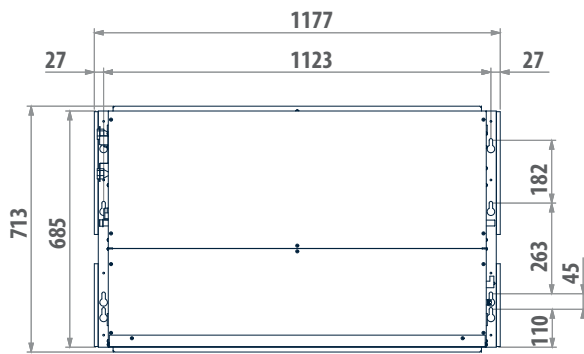
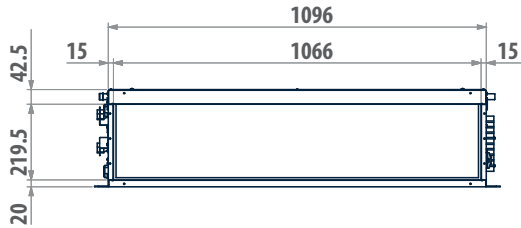
DUCTIMAX 5-6

LEGEND

- | | |
|---|---|
| 1 | Water connections standard heat exchanger \varnothing 3/4" female gas |
| 2 | Water connections additional heat exchanger \varnothing 1/2" female gas |
| 3 | Condensate discharge |

DUCTIMAX	53	54	63	64
ON/OFF motor	x	x	x	x
Inverter-controlled motor	x	x	x	x

x = available

DUCTIMAX	1	2	3	kg	3 mm
53 - 54	3/4	1/2	 	33	17
63 - 64	3/4	1/2	 	39	17

Medium available head duct units with BLDC motor

DUCTIMAX i 2 - 8 kW

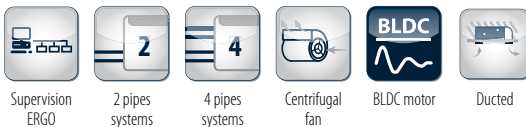

Modulation and efficiency in a recess ceiling-mounted unit

The range is completed by DUCTIMAX i, which uses inverter BLDC technology in the electric motors. To the features of DUCTIMAX it adds the benefits of brushless technology, including a reduction in electricity consumption and consequent reduction in CO₂ emissions, increase in operating flexibility thanks to the modulation of air flow and increase in the level of comfort in terms of temperature, humidity and noise levels.

The range is made up of 12 models with air flows from 300 to 1200 m³/h.

Continuous modulation of the air flow and the use of high-efficiency heat exchangers enables operation also with small air-water temperature differences.

The heat exchangers can also be optimized in the circuit for centralized applications such as district cooling.

Operation is controlled from wall-mounted microprocessor control panels with display, such as the MYCOMFORT LARGE and EVO models which also enable DUCTIMAX i to be connected to ERGO.

The action of the G3 air filter can be combined with an air ionisation system available as an accessory.

PLUS

- » Permanent magnet BLDC motor
- » Low electricity consumption
- » Easy setup of ventilation section
- » Heat exchanger up to 4 rows
- » Compact dimensions
- » Reversible water connections
- » Can be integrated into ERGO
- » Wide range of available accessories

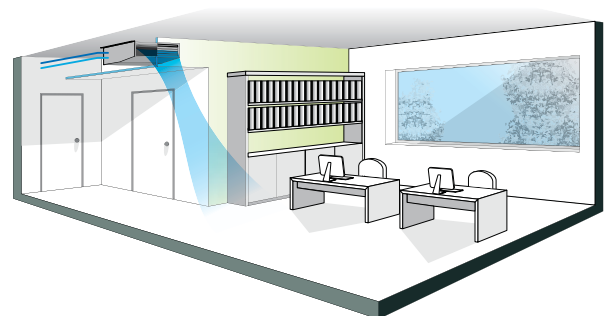

Besides assuring a big advantage in terms of energy efficiency, the inverter-controlled BLDC motor enables flexibility of installation and reduces the time needed to set up the ventilation section, thanks to the continuous modulation of air flow.

AVAILABLE VERSIONS

DMXXDILO...A Units for 2 pipes systems

DMXXDILL...A Unit for 4-pipe systems equipped with an additional 1-row exchanger for the hot water circuit

DMXXDILM...A Unit for 4-pipe systems equipped with an additional 2-row exchanger for the hot water circuit (**On request**)

Available on request air decontamination system installed on special plenum

MAIN COMPONENTS

Structure

Built from galvanised steel sheet, heat and sound insulated by means of Class 1 self-extinguishing panels. Reduced height to facilitate installation in a horizontal position in a false ceiling. The structure incorporates a drip tray and condensate drain outlet.

The main condensate drip tray is situated inside the structure of the unit and is at a positive pressure relative to the drain outlet to facilitate condensate drainage.

Fans

Double suction centrifugal fans made with ABS or aluminium, with statically and dynamically balanced forward-curving blades, directly coupled to the electric motor.



BLDC electric motor

Permanent magnet motor The unit is equipped with an inverter board to control the motor, that makes it possible to precisely set the maximum rotation speed of the motor (control signal 0-10 V).

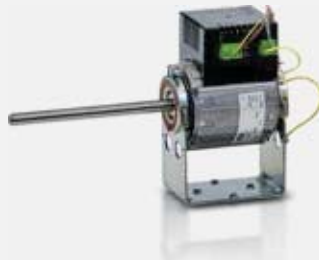

Heat exchanger

High efficiency 3 and 4 rows heat exchanger made with copper piping and aluminium fins blocked to pipings by mechanical expansion, provided with brass manifolds and air vent valve. The heat exchanger usually comes with water connections mounted on the left, but it can be turned by 180°. High-efficiency heat exchangers optimized for district cooling applications are available on request.

Air filter

Washable air filter, made of acrylic fibre, filtration class G2 or G3, applied on the air intake; may be pulled out from below.

ACCESSORIES

Electronic microprocessor control panels with display

DIST	MY COMFORT controller spacer for wall mounting
EVOBOARD	Circuit board for EVO control
EVODISP	User interface with display for EVO controller
MCLE	Microprocessor control with display MY COMFORT LARGE
MCSUE	Humidity sensor for MY COMFORT (medium e large), EVO
MCSWE	Water sensor for MYCOMFORT, EVO, LED 503 controllers

Electronic microprocessor control panels

TED 10	Electronic controller for BLDC fan equipped with inverter and ON/OFF valves 230 V
TED SWA	Water temperature sensor for TED controls

Auxiliary water drip trays, insulating shell, condensate drainage pump

KSC	Condensate drainage pump kit
------------	------------------------------

Electrical heating elements

RE	Heating element with installation kit, relay box and safety devices
-----------	---

Air inlet and outlet grilles

GA	Aluminium air intake grille, with frame
GM	Aluminium air outlet grille with 2-row fins and subframe

Valves

V2VDF+STD	2-way valves, ON/OFF or MODULATING actuator, 230 V or 24 V power supply, hydraulic kit, for main and additional heat exchanger
V2VSTD	2-way valve, ON/OFF or MODULATING actuator, 230 V or 24 V power supply, hydraulic kit, for main heat exchanger

V3VDF	3-way valves, ON/OFF or MODULATING actuator, 230 V or 24 V power supply, hydraulic kit, for additional heat exchanger
--------------	---

V3VSTD	2-way valves, ON/OFF or MODULATING actuator, 230 V or 24 V power supply, hydraulic kit, for main heat exchanger
---------------	---

Plenum, air intake modules, air inlet and outlet connectors

MAFO	Air intake module with G4 air filter
PAF	Intake and delivery plenum, not insulated, with spigot Ø 200 mm
PMA	Intake and delivery plenum, not insulated, with spigot Ø 200 mm
PMAC	Intake and delivery plenum, insulated, with spigot Ø 200 mm
R90	90° uninsulated air inlet/outlet connector
R90C	90° uninsulated air inlet/outlet connector
RD	Straight uninsulated air inlet/outlet connector
RDC	Straight insulated air inlet/outlet connector

Flexible ducts - caps

TFA	Not insulated flexible ducts, Ø 200 mm (6 m length indivisible)
TFM	Insulated flexible ducts, Ø 200 mm (6 m length indivisible)
TP	Plastic cap Ø 200 mm

Air inlet and outlet plenum box

CA	Air Inlet plenum box with double row grille
CAF	Air Inlet plenum box with double row grille 300 x 600 mm and filter G2
CM	Insulated air outlet plenum box with grille

Accessories

VRC	Auxiliary water drip tray
------------	---------------------------

RATED TECHNICAL DATA

DUCTIMAX i			13			14			23			24		
Speed			min	med	max	min	med	max	min	med	max	min	med	max
Control voltage		V	3,60	7,50	8,50	3,60	7,50	8,50	4,10	6,60	8,00	4,10	6,60	8,00
Rated air flow	(E)	m ³ /h	138	246	276	138	246	276	171	275	341	171	275	341
Available static pressure	(E)	Pa	15	50	63	15	50	63	19	50	77	19	50	77
Power input	(E)	W	5	26	35	5	26	35	12	28	43	12	28	43
Total cooling capacity	(1)	kW	1,12	1,78	1,98	1,18	1,97	2,18	1,30	1,97	2,38	1,39	2,18	2,64
Sensible cooling capacity	(1)	kW	0,77	1,28	1,41	0,80	1,36	1,51	0,92	1,41	1,70	0,96	1,51	1,84
Total cooling capacity	(2)(E)	kW	1,11	1,75	1,95	1,17	1,94	2,15	1,29	1,94	2,34	1,38	2,15	2,60
Sensible cooling capacity	(2)(E)	kW	0,76	1,25	1,38	0,79	1,33	1,48	0,91	1,38	1,66	0,95	1,48	1,80
FCEER class	(E)		A			A			B			A		
Water flow	(1)	l/h	192	306	339	203	338	374	223	339	409	239	374	453
Water pressure drop	(1)(E)	kPa	2	5	6	3	7	8	3	6	8	4	8	12
Heating capacity	(3)(E)	kW	1,32	2,18	2,39	1,37	2,38	2,64	1,60	2,38	2,83	1,69	2,64	3,22
Water pressure drop	(3)(E)	kPa	2	4	5	2	6	7	2	5	6	3	7	10
Heating capacity	(4)(E)	kW	1,04	1,71	1,88	1,14	1,98	2,20	1,33	1,98	2,35	1,41	2,20	2,68
FCCOP class	(E)		A											
Water flow	(4)	l/h	181	297	327	198	345	384	231	345	408	244	382	466
Water pressure drop	(4)(E)	kPa	2	4	5	2	6	7	2	5	7	3	7	10
Standard coil - number of rows			3			4			3			4		
Total sound power level		dB(A)	26	48	52	26	48	52	36	50	58	36	50	58
Inlet + radiated sound power level	(E)	dB(A)	24	46	50	24	46	50	34	48	56	34	48	56
Outlet sound power level	(E)	dB(A)	22	45	49	22	45	49	32	47	55	32	47	55
Heating capacity DF 1R	(5)(E)	kW	1,34	1,93	2,06	1,34	1,93	2,06	1,55	2,06	2,32	1,55	2,06	2,32
Water flow DF 1R	(5)	l/h	117	169	182	117	169	182	136	181	204	136	181	204
Water pressure drop DF 1R	(5)(E)	kPa	1	2	3	1	2	3	2	3	3	2	3	3
Additional coil DF - number of rows			1			1			1			1		

DUCTIMAX i			33			34			43			44		
Speed			min	med	max	min	med	max	min	med	max	min	med	max
Control voltage		V	4,20	7,30	8,30	4,20	7,30	8,30	4,00	6,80	8,70	4,00	6,80	8,70
Rated air flow	(E)	m ³ /h	196	360	402	196	360	402	305	532	652	305	532	652
Available static pressure	(E)	Pa	14	50	63	14	50	63	17	50	76	17	50	76
Power input	(E)	W	13	34	45	13	34	45	18	48	82	18	48	82
Total cooling capacity	(1)	kW	1,47	2,36	2,62	1,60	2,77	3,07	2,00	3,31	3,87	2,37	3,92	4,65
Sensible cooling capacity	(1)	kW	1,05	1,77	1,97	1,10	1,93	2,14	1,50	2,53	3,00	1,65	2,75	3,27
Total cooling capacity	(2)(E)	kW	1,46	2,33	2,57	1,59	2,74	3,02	1,98	3,26	3,79	2,35	3,87	4,57
Sensible cooling capacity	(2)(E)	kW	1,04	1,74	1,92	1,09	1,90	2,09	1,48	2,48	2,92	1,63	2,70	3,19
FCEER class	(E)		A			A			B			A		
Water flow	(1)	l/h	253	405	449	275	476	527	343	568	664	407	673	797
Water pressure drop	(1)(E)	kPa	2	5	5	3	7	9	3	8	11	6	14	18
Heating capacity	(3)(E)	kW	1,88	3,20	3,52	1,92	3,36	3,72	2,78	4,40	5,11	2,90	4,74	5,62
Water pressure drop	(3)(E)	kPa	2	4	4	2	6	7	3	7	9	5	11	15
Heating capacity	(4)(E)	kW	1,57	2,70	2,96	1,59	2,80	3,10	2,35	3,70	4,31	2,41	3,95	4,68
FCCOP class	(E)		A											
Water flow	(4)	l/h	274	470	515	277	488	538	408	644	749	419	687	814
Water pressure drop	(4)(E)	kPa	2	5	6	2	6	8	4	9	11	5	12	16
Standard coil - number of rows			3			4			3			4		
Total sound power level		dB(A)	36	52	58	36	52	58	39	52	60	39	52	60
Inlet + radiated sound power level	(E)	dB(A)	34	50	56	34	50	56	37	50	58	37	50	58
Outlet sound power level	(E)	dB(A)	32	49	55	32	49	55	35	47	56	35	47	56
Heating capacity DF 1R	(5)(E)	kW	2,09	3,09	3,29	2,09	3,09	3,29	2,80	3,82	4,24	2,80	3,82	4,24
Water flow DF 1R	(5)	l/h	183	271	288	183	271	288	245	334	371	245	334	371
Water pressure drop DF 1R	(5)(E)	kPa	2	3	4	2	3	4	3	5	6	3	5	6
Additional coil DF - number of rows			1			1			1			1		

NOTE: The dimensional drawings of the DUCTIMAX i inverter units are the same of the DUCTIMAX ON/OFF version. They are reported from page 94

RATED TECHNICAL DATA

DUCTIMAX i			53			54			63			64		
Speed			min	med	max	min	med	max	min	med	max	min	med	max
Control voltage		V	4,20	7,90	8,70	4,20	7,90	8,70	6,90	7,70	8,40	6,90	7,70	8,40
Rated air flow	(E)	m ³ /h	337	687	760	337	687	760	1045	1170	1285	1045	1170	1285
Available static pressure	(E)	Pa	12	50	61	12	50	61	40	50	60	40	50	60
Power input	(E)	W	18	61	77	18	61	77	119	153	189	119	153	189
Total cooling capacity	(1)	kW	2,31	4,39	4,82	2,54	4,95	5,42	6,36	6,98	7,52	7,11	7,81	8,42
Sensible cooling capacity	(1)	kW	1,70	3,26	3,58	1,79	3,50	3,83	4,72	5,19	5,61	5,04	5,54	5,99
Total cooling capacity	(2)(E)	kW	2,29	4,33	4,74	2,52	4,89	5,34	6,24	6,83	7,33	6,99	7,66	8,23
Sensible cooling capacity	(2)(E)	kW	1,68	3,20	3,50	1,77	3,44	3,75	4,60	5,04	5,42	4,92	5,39	5,80
FCEER class	(E)		A			A			C			C		
Water flow	(1)	l/h	397	754	828	436	851	930	1092	1197	1291	1221	1340	1445
Water pressure drop	(1)(E)	kPa	2	7	8	3	10	12	13	16	18	20	23	26
Heating capacity	(3)(E)	kW	3,05	5,66	6,16	3,18	6,04	6,59	7,94	8,65	9,29	8,59	9,40	10,1
Water pressure drop	(3)(E)	kPa	2	6	7	3	8	10	11	13	15	16	19	21
Heating capacity	(4)(E)	kW	2,57	4,75	5,17	2,65	5,03	5,49	6,64	7,23	7,76	7,15	7,84	8,44
FCCOP class	(E)		A			A			B			B		
Water flow	(4)	l/h	446	827	898	462	875	955	1154	1258	1349	1244	1362	1468
Water pressure drop	(4)(E)	kPa	2	7	8	3	9	11	12	14	16	17	20	22
Standard coil - number of rows			3			4			3			4		
Total sound power level		dB(A)	39	55	60	39	55	60	59	62	69	59	62	69
Inlet + radiated sound power level	(E)	dB(A)	37	53	58	37	53	58	57	60	67	57	60	67
Outlet sound power level	(E)	dB(A)	35	51	56	35	51	56	55	58	65	55	58	65
Heating capacity DF 1R	(5)(E)	kW	3,42	5,17	5,45	3,42	5,17	5,45	6,38	6,72	7,00	6,38	6,72	7,00
Water flow DF 1R	(5)	l/h	299	452	477	299	452	477	559	588	613	559	588	613
Water pressure drop DF 1R	(5)(E)	kPa	6	13	14	6	13	14	19	21	22	19	21	22
Additional coil DF - number of rows			1			1			1			1		

(1) Water temperature 7°C / 12°C, air temperature dry bulb 27°C, wet bulb 19°C (47% relative humidity)

(2) According to EN1397:2015

(3) Inlet water temperature 50°C, water flow rate same as in cooling mode, air temperature 20°C

(4) Water temperature 45°C / 40°C, air temperature 20°C

(5) Water temperature 65°C / 55°C, air temperature 20°C

(E) EUROVENT certified data

Power supply 230-1-50 (V-ph-Hz)

NOTE: The dimensional drawings of the DUCTIMAX i inverter units are the same of the DUCTIMAX ON/OFF version. They are reported from page 94

Medium available head duct units

PWN 3 - 10 kW



Versatile and quiet, designed for recess ceiling mounting

The range of PWN duct units is designed for air conditioning systems in interiors requiring the installation of particularly versatile, low-noise, medium-head (up to 80Pa) units.

PWN ducted units are available in 9 different models with flow rates ranging from 400 to 1200 m³/h and cooling capacities from 2.6 to 10.3 kW.

The PWN units are built with a galvanized sheet steel weight-bearing structure, duly insulated, and all models are equipped with a 7-speed electric motor which ensures great flexibility during installation. The heat exchanger is available in 3-, 4- or 6-row versions. The latter is particularly recommended for heat pump systems, in which the outlet water temperature is lower. The exchanger is normally mounted with connections on the left side (the wiring box is present on the same side), but it can be rotated by 180° on the installation site. By installing the accessory external module (additional MDF exchanger) it is possible to connect PWN in 4-pipe systems. PWN units can find a place in commercial buildings, hotel rooms and meeting rooms. They have been conceived with a particular construction enabling the basic model to be expanded by installing a series of accessories so as to adapt PWN to the needs of any horizontal recess ceiling-mount application.

PLUS

- » Standard 7 speed motors
- » Heat exchanger up to 6 rows
- » Available head up to 80 Pa
- » Reduced height across the entire range (240 mm)
- » Amply sized condensate drip tray
- » Wide range of available accessories
- » Can be integrated into ERGO

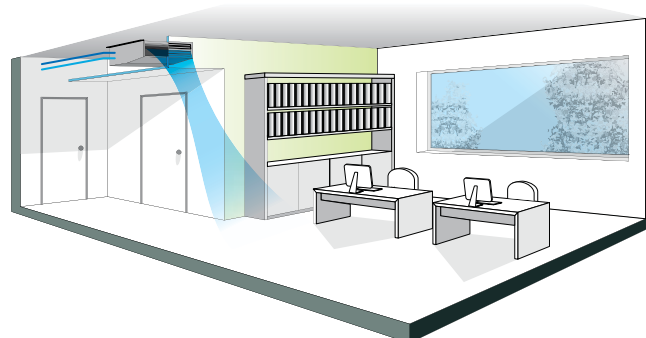

Thanks to the flexibility assured by the 7-speed motor, PWN can be used in numerous applications requiring a precise distribution of air by means of ducts.

Available on request air decontamination system installed on special plenum.

MAIN COMPONENTS

Structure

Built from galvanized sheet steel, designed for horizontal installation, insulated with class 1 self-extinguishing panels, complete with slots for rapid fixing.

Heat exchanger

High efficiency 3, 4 and 6 rows heat exchanger made with copper piping and aluminium fins blocked to pipings by mechanical expansion, provided with brass manifolds and air vent valve. The water connections are reversible.

Fans

Double suction centrifugal fans made with ABS or aluminium, with statically and dynamically balanced forward-curving blades, directly coupled to the electric motor.



Electric motor

Seven-speed electrical motor, mounted on vibration damping couplings, directly connected to the fans, with permanently activated capacitor and winding thermal protection.

Water drip tray

Extended beyond the dimensions of the unit, it can collect condensate both from the heat exchanger and any regulating valves.



Air filter

Washable air filter, made of acrylic fibre, mounted on a galvanised sheet frame protected by a net, easily removable for maintenance operations. Class G3 air filter available as an optional accessory.

ACCESSORIES

Electromechanical control panels

CD	Recess wall-mounted speed switch
CDE	Wall mounted speed selector
TA	Wall-mounted room thermostat
TA2	Electromechanical room thermostat with summer/winter selection
TC	Thermostat for minimum water temperature in heating mode (42 °C)
TD	Wall mounted control with speed selector, thermostat and summer-winter selector
TD4T	Wall-mounted speed selector, thermostat and summer/winter selecting switch, for controlling fan and valves
TDC	Wall mounted control with speed selector and thermostat

Electronic microprocessor control panels with display

COB	Finishing plate for LED 503 controller, RAL9005 black
COG	Finishing plate for LED 503 controller, RAL7031 grey
COW	Finishing plate for LED 503 controller, RAL9003 white
DIST	MY COMFORT controller spacer for wall mounting
EVOBOARD	Circuit board for EVO control
EVODISP	User interface with display for EVO controller
LED503	Recessed wall-mounted electronic display controller LED 503
MCBE	MYCOMFORT BASE electronic controller with display
MCLE	Microprocessor control with display MY COMFORT LARGE
MCME	MYCOMFORT MEDIUM electronic controller with display
MCSUE	Humidity sensor for MY COMFORT (medium e large), EVO
MCSWE	Water sensor for MYCOMFORT, EVO, LED 503 controllers

Electronic microprocessor control panels

TED 2T	Electronic controller for AC fan control and one ON/OFF 230 V valve
TED 4T	Electronic controller for AC fan control and two ON/OFF 230 V valves
TED SWA	Water temperature sensor for TED controls

Power interface and regulating louver controllers

CSD	Recess mounted controller for opening and closing the SM motor-driven regulating louver
KP	Power interface for connecting in parallel up to 4 fun coil units to the one controller

Additional heat exchanger for 4-pipe systems

MDF	Additional heat exchanger module for hot water operation.
Auxiliary water drip trays, insulating shell, condensate drainage pump	
KSC	Condensate drainage pump kit

Electrical heating elements

RE	Heating element with installation kit, relay box and safety devices
-----------	---

Air inlet and outlet grilles

GA	Aluminium air intake grille, with frame
GM	Aluminium air outlet grille with 2-row fins and subframe

External air intake louvers

SM	Motorized air intake louver
-----------	-----------------------------

Valves

V2VDF+STD	2-way valves, ON/OFF or MODULATING actuator, 230 V or 24 V power supply, hydraulic kit, for main and additional heat exchanger
V2VSTD	2-way valve, ON/OFF or MODULATING actuator, 230 V or 24 V power supply, hydraulic kit, for main heat exchanger
V3VDF	3-way valves, ON/OFF or MODULATING actuator, 230 V or 24 V power supply, hydraulic kit, for additional heat exchanger
V3VSTD	2-way valves, ON/OFF or MODULATING actuator, 230 V or 24 V power supply, hydraulic kit, for main heat exchanger

Plenum, air intake modules, air inlet and outlet connectors

PAF	Intake and delivery plenum, not insulated, with spigot Ø 200 mm
PMA	Intake and delivery plenum, not insulated, with spigot Ø 200 mm
PMAC	Intake and delivery plenum, insulated, with spigot Ø 200 mm
R90	90° uninsulated air inlet/outlet connector
R90C	90° uninsulated air inlet/outlet connector
RD	Straight uninsulated air inlet/outlet connector
RDC	Straight insulated air inlet/outlet connector

Flexible ducts - caps

TFA	Not insulated flexible ducts, Ø 200 mm (6 m length indivisible)
TFM	Insulated flexible ducts, Ø 200 mm (6 m length indivisible)
TP	Plastic cap Ø 200 mm

Air inlet and outlet plenum box

CA	Air Inlet plenum box with double row grille
CAF	Air Inlet plenum box with double row grille 300 x 600 mm and filter G2
CM	Insulated air outlet plenum box with grille

Silencers

SIL	Plenum silencer for air intake/outlet
------------	---------------------------------------

Accessories

FG3	G3-class air filter
------------	---------------------

RATED TECHNICAL DATA

PWN			13			14			16		
Speed			min	med	max	min	med	max	min	med	max
Rated air flow	(E)	m ³ /h	184	297	371	184	297	371	184	297	371
Available static pressure	(E)	Pa	19	50	78	19	50	70	19	50	70
Power input	(E)	W	34	69	106	34	69	106	34	69	106
Total cooling capacity	(1)	kW	1,36	1,98	2,43	1,52	2,38	2,93	1,70	2,60	3,24
Sensible cooling capacity	(1)	kW	0,93	1,44	1,76	1,04	1,64	2,01	1,12	1,75	2,18
Total cooling capacity	(2)(E)	kW	1,33	1,91	2,32	1,49	2,31	2,82	1,67	2,53	3,13
Sensible cooling capacity	(2)(E)	kW	0,93	1,37	1,65	1,01	1,57	1,90	1,09	1,68	2,07
FCEER class	(E)		D			D			C		
Water flow	(1)	l/h	219	340	418	256	410	502	283	448	555
Water pressure drop	(1)(E)	kPa	2	5	7	4	8	12	3	7	10
Heating capacity	(3)(E)	kW	1,66	2,52	3,04	1,77	2,76	3,37	1,84	2,92	3,61
Water pressure drop	(3)(E)	kPa	2	5	7	4	8	12	3	7	10
Heating capacity	(4)(E)	kW	1,39	2,11	2,54	1,48	2,29	2,80	1,53	2,43	3,00
FCCOP class	(E)		C								
Water flow	(4)	l/h	242	367	442	256	399	486	265	422	521
Water pressure drop	(4)(E)	kPa	2	5	6	3	7	9	2	5	7
Standard coil - number of rows			3			4			6		
Total sound power level		dB(A)	36	50	58	36	50	58	38	50	58
Inlet + radiated sound power level	(E)	dB(A)	33	46	55	33	46	55	36	46	55
Outlet sound power level	(E)	dB(A)	33	47	55	33	47	55	33	47	55
Heating capacity MDF	(5)(E)	kW	1,71	2,30	2,60	1,71	2,30	2,60	1,71	2,30	2,60
Water flow MDF	(5)	l/h	149	201	228	149	201	228	149	201	228
Water pressure drop MDF	(5)(E)	kPa	1	2	2	1	2	3	1	2	2
Additional coil MDF - number of rows			2			2			2		

(1) Water temperature 7°C / 12°C, air temperature dry bulb 27°C, wet bulb 19°C (47% relative humidity)

(2) According to EN1397:2015

(3) Inlet water temperature 50°C, water flow rate same as in cooling mode, air temperature 20°C

(4) Water temperature 45°C / 40°C, air temperature 20°C

(5) Water temperature 65°C / 55°C, air temperature 20°C

(E) EUROVENT certified data

Power supply 230-1-50 (V-ph-Hz)

RATED TECHNICAL DATA

PWN			23			24			26		
Speed			min	med	max	min	med	max	min	med	max
Rated air flow	(E)	m ³ /h	283	576	722	331	576	722	331	576	722
Available static pressure	(E)	Pa	16	50	79	16	50	79	16	50	79
Power input	(E)	W	76	143	192	76	143	192	76	143	192
Total cooling capacity	(1)	kW	1,85	3,84	4,66	2,33	3,92	4,93	2,71	4,76	5,88
Sensible cooling capacity	(1)	kW	1,38	2,74	3,31	1,69	2,84	3,52	1,86	3,24	4,01
Total cooling capacity	(2)(E)	kW	2,17	3,70	4,47	2,52	3,78	4,74	2,80	4,62	5,69
Sensible cooling capacity	(2)(E)	kW	1,56	2,60	3,12	1,73	2,70	3,33	1,86	3,10	3,82
FCEER class	(E)		D								
Water flow	(1)	l/h	318	659	799	400	674	847	465	817	1009
Water pressure drop	(1)(E)	kPa	3	9	13	2	5	8	3	8	12
Heating capacity	(3)(E)	kW	2,93	4,71	5,65	3,07	5,07	6,18	3,24	5,47	6,71
Water pressure drop	(3)(E)	kPa	3	9	13	2	5	8	3	8	12
Heating capacity	(4)(E)	kW	2,14	3,93	4,70	2,58	4,25	5,15	2,71	4,53	5,56
FCCOP class	(E)		D			D			C		
Water flow	(4)	l/h	372	684	819	448	739	898	469	789	969
Water pressure drop	(4)(E)	kPa	3	8	11	2	4	6	3	7	9
Standard coil - number of rows			3			4			6		
Total sound power level		dB(A)	39	52	60	39	52	60	39	52	60
Inlet + radiated sound power level	(E)	dB(A)	37	49	57	37	49	57	37	49	57
Outlet sound power level	(E)	dB(A)	34	49	57	34	49	57	34	49	57
Heating capacity MDF	(5)(E)	kW	3,11	4,37	4,92	3,14	4,37	4,92	3,14	4,37	4,92
Water flow MDF	(5)	l/h	273	383	431	273	383	431	273	383	431
Water pressure drop MDF	(5)(E)	kPa	5	9	11	5	9	12	5	9	11
Additional coil MDF - number of rows			2			2			2		

- (1) Water temperature 7°C / 12°C, air temperature dry bulb 27°C, wet bulb 19°C (47% relative humidity)
(2) According to EN1397:2015
(3) Inlet water temperature 50°C, water flow rate same as in cooling mode, air temperature 20°C
(4) Water temperature 45°C / 40°C, air temperature 20°C
(5) Water temperature 65°C / 55°C, air temperature 20°C
(E) EUROVENT certified data
Power supply 230-1-50 (V-ph-Hz)

RATED TECHNICAL DATA

PWN			33			34			36		
Speed			min	med	max	min	med	max	min	med	max
Rated air flow	(E)	m ³ /h	572	715	905	572	715	905	572	715	905
Available static pressure	(E)	Pa	32	50	80	32	50	80	32	50	80
Power input	(E)	W	155	193	294	155	193	294	155	193	294
Total cooling capacity	(1)	kW	3,98	4,88	5,99	4,41	5,47	6,77	5,09	6,34	7,94
Sensible cooling capacity	(1)	kW	2,82	3,44	4,19	3,07	3,79	4,68	3,40	4,24	5,31
Total cooling capacity	(2)(E)	kW	3,83	4,69	5,70	4,25	5,28	6,48	4,93	6,15	7,65
Sensible cooling capacity	(2)(E)	kW	2,67	3,25	3,90	2,92	3,60	4,39	3,25	4,05	5,02
FCEER class	(E)		D								
Water flow	(1)	l/h	683	839	1028	758	938	1162	874	1089	1363
Water pressure drop	(1)(E)	kPa	7	10	14	6	9	13	8	11	17
Heating capacity	(3)(E)	kW	4,92	5,94	5,98	5,30	6,48	7,94	5,64	6,98	8,71
Water pressure drop	(3)(E)	kPa	7	10	10	6	9	13	8	11	17
Heating capacity	(4)(E)	kW	4,11	4,95	5,95	4,42	5,39	6,57	4,69	5,80	7,18
FCCOP class	(E)		D								
Water flow	(4)	l/h	714	861	1040	768	937	1148	815	1008	1256
Water pressure drop	(4)(E)	kPa	6	8	11	5	8	11	6	8	12
Standard coil - number of rows			3			4			6		
Total sound power level		dB(A)	53	59	69	53	59	69	53	64	69
Inlet + radiated sound power level	(E)	dB(A)	50	55	65	50	55	65	50	63	65
Outlet sound power level	(E)	dB(A)	50	56	66	50	56	66	50	59	66
Heating capacity MDF	(5)(E)	kW	6,41	7,55	8,95	6,41	7,55	8,95	5,75	6,77	8,03
Water flow MDF	(5)	l/h	558	661	785	558	661	785	558	661	785
Water pressure drop MDF	(5)(E)	kPa	2	3	4	2	3	4	2	3	4
Additional coil MDF - number of rows			2			2			2		

(1) Water temperature 7°C / 12°C, air temperature dry bulb 27°C, wet bulb 19°C (47% relative humidity)

(2) According to EN1397:2015

(3) Inlet water temperature 50°C, water flow rate same as in cooling mode, air temperature 20°C

(4) Water temperature 45°C / 40°C, air temperature 20°C

(5) Water temperature 65°C / 55°C, air temperature 20°C

(E) EUROVENT certified data

Power supply 230-1-50 (V-ph-Hz)

DIMENSIONAL DRAWINGS

PWN

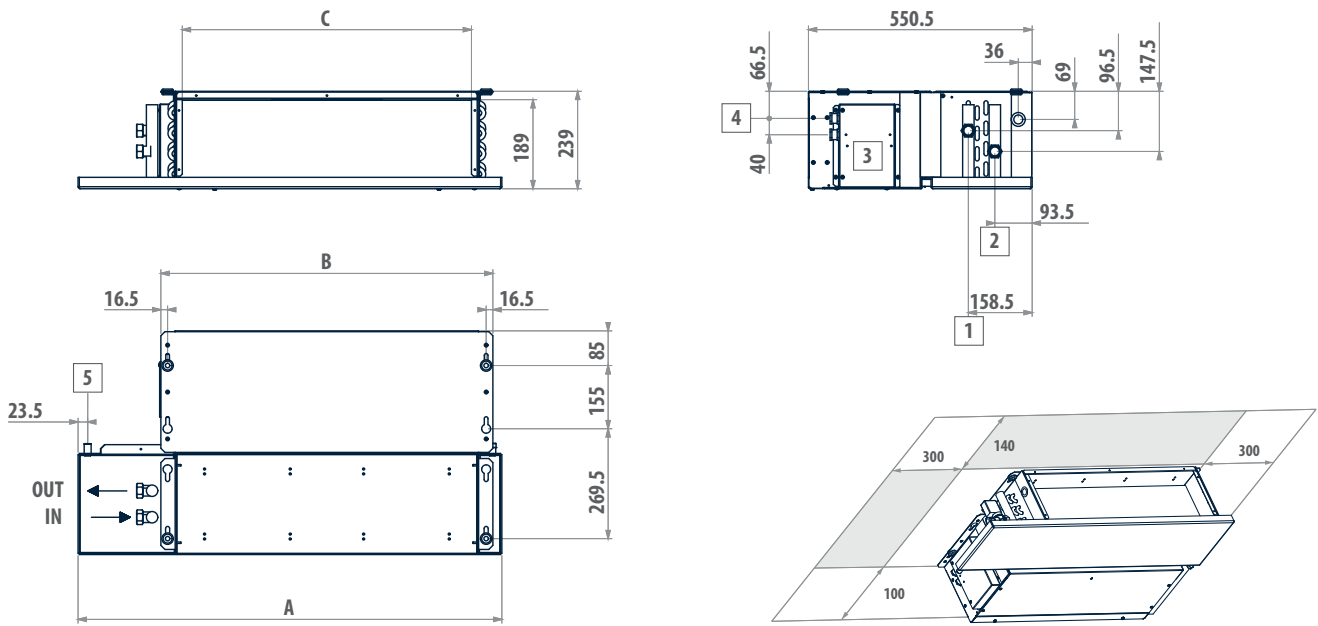

LEGEND

- | | |
|---|--|
| 1 | Water outlet \varnothing 3/4" female gas |
| 2 | Water inlet \varnothing 3/4" female gas |
| 3 | Electric box |
| 4 | Power supply cable holder |
| 5 | Condensate discharge \varnothing 17 mm |

PWN	A mm	B mm	C mm	1 "	2 "	5 mm	 kg
13 - 14 - 16	1039	814	709	3/4	3/4	17	26 - 27 - 29
23 - 24 - 26	1389	1164	1059	3/4	3/4	17	35 - 37 - 39
33 - 34 - 36	1739	1514	1409	3/4	3/4	17	47 - 49 - 53

Models 33, 34 and 36 available ON/OFF version only

Medium available head duct units with BLDC motor

PWN i 2 - 6 kW

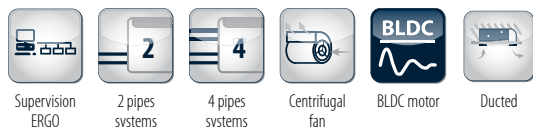

PLUS

- » BLDC inverter motors
- » Reduced height across the entire range (240 mm)
- » Available head up to 80 Pa
- » Heat exchanger up to 6 rows
- » Amply sized condensate drip tray
- » Wide range of available accessories
- » Can be integrated into ERGO networks

Efficiency and versatility for recess ceiling mounted units

The range of PWN i duct units is designed for air conditioning systems in interiors requiring the installation of particularly versatile, low-noise, medium-head (up to 80Pa) units. Unlike the models equipped with traditional motors of the ON-OFF type, PWN i units feature fan assemblies with inverter-controlled permanent magnet BLDC motors. Adopting this type of motor makes it possible to obtain considerable reductions in electricity consumption and CO₂ emissions, as well as a considerable reduction in noise for enhanced comfort.

The DC Inverter technology allows to continuously adjust the air flow to the actual needs of the environment by considerably reducing the fluctuations in room temperature. By virtue of the continuous modulation of the air flow, once the right temperature and humidity conditions have been reached the fan speed is considerably reduced, resulting in decidedly low noise levels.

The heat exchanger is available in 3-, 4- or 6-row versions. The latter is particularly recommended for heat pump systems, in which the outlet water temperature is lower. The exchanger is normally mounted with connections on the left side (the wiring box is present on the same side), but it can be rotated by 180° on the installation site. By installing the accessory external module (additional MDF exchanger) it is possible to connect PWN i in 4-pipe systems.

PWN i units can find a place in commercial buildings, hotel rooms and meeting rooms. They have been conceived with a particular construction enabling the basic model to be expanded by installing a series of accessories so as to adapt PWN i to the needs of any horizontal recess ceiling-mount application.

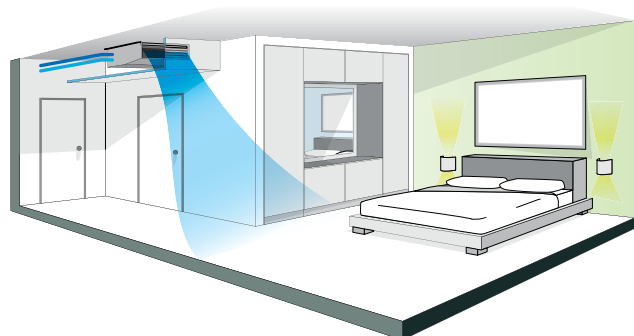

The flexibility of the inverter control makes it possible to reduce the rotation speed to minimal values which almost completely eliminate the noise emissions of false-ceiling installations.

Available on request air decontamination system installed on special plenum.

MAIN COMPONENTS
Structure

Built from galvanized sheet steel, designed for horizontal installation, insulated with class 1 self-extinguishing panels, complete with slots for rapid fixing.

Heat exchanger

High efficiency 3, 4 and 6 rows heat exchanger made with copper piping and aluminium fins blocked to pipings by mechanical expansion, provided with brass manifolds and air vent valve. The water connections are reversible.

Fans

Double suction centrifugal fans made with ABS or aluminium, with statically and dynamically balanced forward-curved blades, directly coupled to the electric motor.

BLDC electric motor

Permanent magnet motor The unit is equipped with an inverter board to control the motor, that makes it possible to precisely set the maximum rotation speed of the motor (control signal 0-10 V).

Water drip tray

Extended beyond the dimensions of the unit, it can collect condensate both from the heat exchanger and any regulating valves.

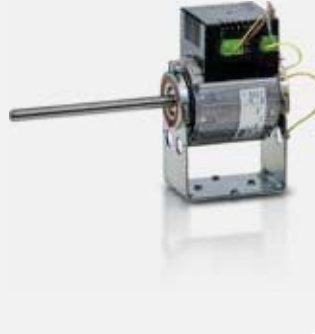
Air filter

Washable air filter, made of acrylic fibre, mounted on a galvanised sheet frame protected by a net, easily removable for maintenance operations. Class G3 air filter available as an optional accessory.

ACCESSORIES

Electronic microprocessor control panels with display		V2VSTD	2-way valve, ON/OFF or MODULATING actuator, 230 V or 24 V power supply, hydraulic kit, for main heat exchanger
DIST	MY COMFORT controller spacer for wall mounting	V3VDF	3-way valves, ON/OFF or MODULATING actuator, 230 V or 24 V power supply, hydraulic kit, for additional heat exchanger
EVOBOARD	Circuit board for EVO control	V3VSTD	2-way valves, ON/OFF or MODULATING actuator, 230 V or 24 V power supply, hydraulic kit, for main heat exchanger
EVODISP	User interface with display for EVO controller	Plenum, air intake modules, air inlet and outlet connectors	
MCLE	Microprocessor control with display MY COMFORT LARGE	PAF	Intake and delivery plenum, not insulated, with spigot Ø 200 mm
MCSUE	Humidity sensor for MY COMFORT (medium e large), EVO	PMA	Intake and delivery plenum, not insulated, with spigot Ø 200 mm
MCSWE	Water sensor for MYCOMFORT, EVO, LED 503 controllers	PMAC	Intake and delivery plenum, insulated, with spigot Ø 200 mm
Electronic microprocessor control panels		R90	90° uninsulated air inlet/outlet connector
TED 10	Electronic controller for BLDC fan equipped with inverter and ON/OFF valves 230 V	R90C	90° uninsulated air inlet/outlet connector
TED SWA	Water temperature sensor for TED controls	RD	Straight uninsulated air inlet/outlet connector
Power interface and regulating louver controllers		RDC	Straight insulated air inlet/outlet connector
CSD	Recess mounted controller for opening and closing the SM motor-driven regulating louver	Flexible ducts - caps	
Additional heat exchanger for 4-pipe systems		TFA	Not insulated flexible ducts, Ø 200 mm (6 m length indivisible)
MDF	Additional heat exchanger module for hot water operation.	TFM	Insulated flexible ducts, Ø 200 mm (6 m length indivisible)
Auxiliary water drip trays, insulating shell, condensate drainage pump		TP	Plastic cap Ø 200 mm
KSC	Condensate drainage pump kit	Air inlet and outlet plenum box	
Electrical heating elements		CA	Air Inlet plenum box with double row grille
RE	Heating element with installation kit, relay box and safety devices	CAF	Air Inlet plenum box with double row grille 300 x 600 mm and filter G2
Air inlet and outlet grilles		CM	Insulated air outlet plenum box with grille
GA	Aluminium air intake grille, with frame	Silencers	
GM	Aluminium air outlet grille with 2-row fins and subframe	SIL	Plenum silencer for air intake/outlet
External air intake louvers		Accessories	
SM	Motorized air intake louver	FG3	G3-class air filter
Valves			
V2VDF+STD	2-way valves, ON/OFF or MODULATING actuator, 230 V or 24 V power supply, hydraulic kit, for main and additional heat exchanger		

RATED TECHNICAL DATA

PWN i			13			14			16		
Speed			min	med	max	min	med	max	min	med	max
Control voltage		V	4,10	6,30	8,60	4,10	6,30	8,60	4,10	6,30	8,60
Rated air flow	(E)	m ³ /h	184	297	371	184	297	371	184	297	371
Available static pressure	(E)	Pa	19	50	78	19	50	70	19	50	70
Power input	(E)	W	12	27	46	12	29	43	12	29	43
Total cooling capacity	(1)	kW	1,36	1,98	2,43	1,52	2,39	2,93	1,70	2,61	3,24
Sensible cooling capacity	(1)	kW	0,93	1,44	1,76	1,04	1,64	2,01	1,12	1,75	2,18
Total cooling capacity	(2)(E)	kW	1,35	1,95	2,38	1,51	2,36	2,89	1,69	2,58	3,20
Sensible cooling capacity	(2)(E)	kW	0,92	1,41	1,71	1,03	1,61	1,97	1,11	1,72	2,14
FCEER class	(E)		A								
Water flow	(1)	l/h	219	340	418	256	410	502	283	448	555
Water pressure drop	(1)(E)	kPa	2	5	7	4	8	12	3	7	10
Heating capacity	(3)(E)	kW	1,66	2,52	3,04	1,77	2,76	3,37	1,84	2,92	3,61
Water pressure drop	(3)(E)	kPa	2	5	7	4	8	12	3	7	10
Heating capacity	(4)(E)	kW	1,39	2,11	2,54	1,48	2,29	2,80	1,53	2,43	3,00
FCCOP class	(E)		A								
Water flow	(4)	l/h	242	367	442	256	399	486	265	422	521
Water pressure drop	(4)(E)	kPa	2	5	6	3	7	9	2	5	7
Standard coil - number of rows			3			4			6		
Total sound power level		dB(A)	36	50	58	36	50	58	38	50	58
Inlet + radiated sound power level	(E)	dB(A)	33	46	55	33	46	55	36	46	55
Outlet sound power level	(E)	dB(A)	33	47	55	33	47	55	33	47	55
Heating capacity MDF	(5)(E)	kW	1,71	2,30	2,60	1,71	2,30	2,60	1,71	2,30	2,60
Water flow MDF	(5)	l/h	149	201	228	149	201	228	149	201	228
Water pressure drop MDF	(5)(E)	kPa	1	2	2	1	2	3	1	2	2
Additional coil MDF - number of rows			2			2			2		

(1) Water temperature 7°C / 12°C, air temperature dry bulb 27°C, wet bulb 19°C (47% relative humidity)

(2) According to EN1397:2015

(3) Inlet water temperature 50°C, water flow rate same as in cooling mode, air temperature 20°C

(4) Water temperature 45°C / 40°C, air temperature 20°C

(5) Water temperature 65°C / 55°C, air temperature 20°C

(E) EUROVENT certified data

Power supply 230-1-50 (V-ph-Hz)

NOTE: The dimensional drawings of the PWN i inverter units are the same of the PWN ON/OFF version. They are reported from page 105

RATED TECHNICAL DATA

PWN i			23			24			26		
Speed			min	med	max	min	med	max	min	med	max
Control voltage		V	4,20	6,60	8,90	4,20	6,60	8,90	4,20	6,60	8,90
Rated air flow	(E)	m ³ /h	283	576	722	331	576	722	331	576	722
Available static pressure	(E)	Pa	16	50	79	16	50	79	16	50	79
Power input	(E)	W	16	46	76	18	46	76	18	46	76
Total cooling capacity	(1)	kW	1,85	3,84	4,66	2,33	3,93	4,93	2,71	4,76	5,88
Sensible cooling capacity	(1)	kW	1,38	2,74	3,31	1,69	2,84	3,52	1,86	3,24	4,01
Total cooling capacity	(2)(E)	kW	1,83	3,79	4,58	2,31	3,88	4,85	2,69	4,71	5,80
Sensible cooling capacity	(2)(E)	kW	1,36	2,69	3,23	1,67	2,79	3,44	1,84	3,19	3,93
FCEER class	(E)		A								
Water flow	(1)	l/h	318	659	799	400	674	847	465	817	1009
Water pressure drop	(1)(E)	kPa	3	9	13	2	5	8	3	8	12
Heating capacity	(3)(E)	kW	2,93	4,71	5,65	3,07	5,07	6,18	3,24	5,47	6,71
Water pressure drop	(3)(E)	kPa	3	9	13	2	5	8	3	8	12
Heating capacity	(4)(E)	kW	2,14	3,93	4,70	2,81	4,25	5,15	2,71	4,53	5,56
FCCOP class	(E)		A								
Water flow	(4)	l/h	372	684	819	489	739	898	469	789	969
Water pressure drop	(4)(E)	kPa	3	8	11	2	4	6	3	7	9
Standard coil - number of rows			3			4			6		
Total sound power level		dB(A)	39	52	60	39	52	60	39	52	60
Inlet + radiated sound power level	(E)	dB(A)	37	49	57	37	49	57	37	49	57
Outlet sound power level	(E)	dB(A)	34	49	57	34	49	57	34	49	57
Heating capacity MDF	(5)(E)	kW	3,11	4,37	4,92	3,14	4,37	4,92	3,14	4,37	4,92
Water flow MDF	(5)	l/h	273	383	431	273	383	431	273	383	431
Water pressure drop MDF	(5)(E)	kPa	5	9	11	5	9	12	5	9	11
Additional coil MDF - number of rows			2			2			2		

(1) Water temperature 7°C / 12°C, air temperature dry bulb 27°C, wet bulb 19°C (47% relative humidity)

(2) According to EN1397:2015

(3) Inlet water temperature 50°C, water flow rate same as in cooling mode, air temperature 20°C

(4) Water temperature 45°C / 40°C, air temperature 20°C

(5) Water temperature 65°C / 55°C, air temperature 20°C

(E) EUROVENT certified data

Power supply 230-1-50 (V-ph-Hz)

NOTE: The dimensional drawings of the PWN i inverter units are the same of the PWN ON/OFF version. They are reported from page 105

High-head thermal ventilating units

UTN 3 - 23 kW



Flexibility of installation to respond to every need

The UTN range of thermal ventilating units has been developed for air conditioning rooms where the use of ducted hydronic indoor units capable of assuring available heads of up to 180 Pa and cooling capacities of 3 to 23 kW is required. The units are characterised by a high flexibility of installation, as they can in fact be positioned either vertically or horizontally and the orientation of the air intake in the rear or front part of the unit itself can be modified by simply moving the inspection panel. All units have a standard configuration for the intake of fresh air and slots for rapidly fixing them to the wall or ceiling. Their reduced height (280 mm up to size 16 and 350 mm for larger sizes) enables them to be accommodated in normal false ceiling and the availability of a wide range of plumbing and ventilation accessories makes it easy to integrate them into air conditioning systems. The units are available in standard and high-efficiency models, depending on the finned block exchanger used, so that they can be better adapted to the needs of the room to be air-conditioned.



PLUS

- » Compact dimensions (height 280 mm up to size 16 and 350 mm for larger sizes)
- » Vertical and horizontal installation
- » Wide range of available accessories for simple integration into the system
- » Available head up to 180 Pa
- » High flexibility of installation
- » Can be integrated into ERGO

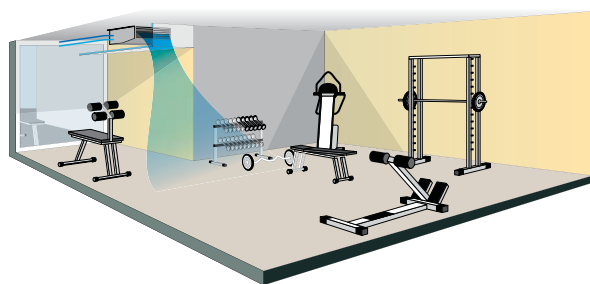

Comfort and hygiene

Available on request air decontamination system installed on special plenum.

AVAILABLE VERSIONS

UTXXX0L0...0A Thermal ventilating unit suitable for 2-pipe systems

UTXXX0LL...0A Thermal ventilating unit suitable for 4-pipe systems (2 heat exchangers)

UTXXX0L0...02

The version with double panelling is made with pre-painted sheet steel insulated with class 0 fire-resistant rockwool **(On request)**

MAIN COMPONENTS

Structure

Made of galvanized sheet steel insulated with sound-deadening, heat-insulating, self-extinguishing closed-cell material to reduce noise emissions and prevent the formation of condensate on the outside surface.

Heat exchanger

It is composed of copper tubing and aluminium fins fixed by expansion. Water connections are reversible. An additional exchanger is available for installing the unit in 4-pipe systems.

Fan

The aluminium fans are of the centrifugal type, with double suction and staggered blades to reduce noise emissions. They are statically and dynamically balanced to minimize the stresses transmitted to the motor shaft.



Filter module

The air filter, made of regenerable acrylic fibre, is available as an accessory in filtration classes G2 or G4.



Electric motor

Three-speed electrical motor, mounted on vibration damping couplings, directly connected to the fans, with permanently activated capacitor and winding thermal protection.

Condensate collection and drainage system

It consists of two insulated galvanized sheet steel trays designed for horizontal and vertical installation.

ACCESSORIES

Electromechanical control panels

CD	Recess wall-mounted speed switch
CDE	Wall mounted speed selector
IPM	Circuit board for connection of UTN 30-30A-40-40A to control panels.
TA	Wall-mounted room thermostat
TA2	Electromechanical room thermostat with summer/winter selection
TC	Thermostat for minimum water temperature in heating mode (42 °C)
TD	Wall mounted control with speed selector, thermostat and summer-winter selector
TD4T	Wall-mounted speed selector, thermostat and summer/winter selecting switch, for controlling fan and valves
TDC	Wall mounted control with speed selector and thermostat

Electronic microprocessor control panels with display

COB	Finishing plate for LED 503 controller, RAL9005 black
COG	Finishing plate for LED 503 controller, RAL7031 grey
COW	Finishing plate for LED 503 controller, RAL9003 white
DIST	MY COMFORT controller spacer for wall mounting
EVOBOARD	Circuit board for EVO control
EVO DISP	User interface with display for EVO controller
LED503	Recessed wall-mounted electronic display controller LED 503
MCBE	MYCOMFORT BASE electronic controller with display
MCLE	Microprocessor control with display MY COMFORT LARGE
MCME	MYCOMFORT MEDIUM electronic controller with display
MCSUE	Humidity sensor for MY COMFORT (medium e large), EVO
MCSWE	Water sensor for MYCOMFORT, EVO, LED 503 controllers

Electronic microprocessor control panels

TED 2T	Electronic controller for AC fan control and one ON/OFF 230 V valve
TED 4T	Electronic controller for AC fan control and two ON/OFF 230 V valves
TED SWA	Water temperature sensor for TED controls

Power interface and regulating louver controllers

CSD	Recess mounted controller for opening and closing the SM motor-driven regulating louver
KP	Power interface for connecting in parallel up to 4 fan coil units to the one controller

Auxiliary water drip trays, insulating shell, condensate drainage pump

KSC	Condensate drainage pump kit
------------	------------------------------

Electrical heating elements

RE	Heating element with installation kit, relay box and safety devices
-----------	---

Air inlet and outlet grilles

GA	Aluminium air intake grille, with frame
GM	Aluminium air outlet grille with 2-row fins and subframe
GR	Air intake grille with subframe
GRF	Air intake grille with subframe and filter

External air intake louvers

PA90	Motor-driven external air intake louver
-------------	---

Valves

V2VDF+STD	2-way valves, ON/OFF or MODULATING actuator, 230 V or 24 V power supply, hydraulic kit, for main and additional heat exchanger
V2VSTD	2-way valve, ON/OFF or MODULATING actuator, 230 V or 24 V power supply, hydraulic kit, for main heat exchanger
V3VDF	3-way valves, ON/OFF or MODULATING actuator, 230 V or 24 V power supply, hydraulic kit, for additional heat exchanger
V3VSTD	2-way valves, ON/OFF or MODULATING actuator, 230 V or 24 V power supply, hydraulic kit, for main heat exchanger

Plenum, air intake modules, air inlet and outlet connectors

G90	90° connection for intake/delivery
MAF	Air intake module with G2 air filter
MAFO	Air intake module with G4 air filter
PCOC	Junction panel with rectangular duct
PCOF	Junction panel with flexible circular duct Ø 200

Flexible ducts - caps

TFA	Not insulated flexible ducts, Ø 200 mm (6 m length indivisible)
TFM	Insulated flexible ducts, Ø 200 mm (6 m length indivisible)
TP	Plastic cap Ø 200 mm

Air inlet and outlet plenum box

CA	Air Inlet plenum box with double row grille
CAF	Air Inlet plenum box with double row grille 300 x 600 mm and filter G2
CM	Insulated air outlet plenum box with grille

Accessories

UYBP	Hot water post-heating exchanger kit
VRCH	Auxiliary water drip tray for horizontal installation units
VRCV	Auxiliary water drip tray for vertical installation units

RATED TECHNICAL DATA

UTN			6A			6D			8A			8D		
Speed			min	med	max	min	med	max	min	med	max	min	med	max
Rated air flow	(E)	m³/h	344	458	561	348	465	572	531	692	792	534	700	802
Available static pressure	(E)	Pa	28	50	75	28	50	75	30	50	65	29	50	65
Power input	(E)	W	84	122	188	84	122	188	135	185	265	135	185	265
Total cooling capacity	(1)	kW	2,30	3,00	3,58	2,02	2,58	3,03	3,42	4,27	4,76	2,87	3,54	3,91
Sensible cooling capacity	(1)	kW	1,71	2,25	2,71	1,55	1,99	2,36	2,58	3,26	3,68	2,23	2,77	3,09
Total cooling capacity	(2)(E)	kW	2,22	2,88	3,39	1,94	2,46	2,84	3,29	4,09	4,50	2,74	3,36	3,65
Sensible cooling capacity	(2)(E)	kW	1,63	2,13	2,52	1,47	1,87	2,17	2,45	3,07	3,42	2,09	2,59	2,82
FCEER class	(E)		D			E			E			E		
Water flow	(1)	l/h	395	515	614	347	442	521	587	732	817	493	607	671
Water pressure drop	(1)(E)	kPa	4	6	9	5	8	11	8	12	14	10	14	17
Heating capacity	(3)(E)	kW	2,94	3,75	4,43	2,61	3,27	3,82	4,24	5,22	5,79	3,63	4,41	4,85
Water pressure drop	(3)(E)	kPa	3	5	7	4	7	9	7	10	12	8	12	14
Heating capacity	(4)(E)	kW	2,47	3,14	3,70	2,19	2,75	3,20	3,55	4,36	4,83	3,04	3,69	4,05
FCCOP class	(E)		D											
Water flow	(4)	l/h	428	545	643	382	477	556	617	758	840	529	641	705
Water pressure drop	(4)(E)	kPa	4	6	8	5	8	10	7	11	13	9	13	15
Standard coil - number of rows			4			3			4			3		
Total sound power level		dB(A)	48	57	63	48	57	63	54	61	66	54	61	66
Inlet + radiated sound power level	(E)	dB(A)	46	54	61	46	54	61	52	59	64	52	59	64
Outlet sound power level	(E)	dB(A)	45	53	59	45	53	59	51	58	63	51	58	63
Heating capacity DF	(5)(E)	kW	2,56	2,99	3,31	2,58	3,02	3,34	3,23	3,66	3,89	3,23	3,68	3,91
Water flow DF	(5)	l/h	224	262	290	226	264	292	283	320	340	283	322	342
Water pressure drop DF	(5)(E)	kPa	3	4	5	3	5	5	5	6	7	5	6	7
Additional coil DF - number of rows			1			1			1			1		

UTN			12A			12D			16A			16D		
Speed			min	med	max	min	med	max	min	med	max	min	med	max
Rated air flow	(E)	m³/h	998	1107	1206	1021	1134	1241	1200	1371	1584	1208	1384	1609
Available static pressure	(E)	Pa	41	50	59	41	50	59	38	50	66	38	50	67
Power input	(E)	W	345	385	460	345	385	460	290	380	505	290	380	505
Total cooling capacity	(1)	kW	5,87	6,37	6,81	5,33	5,77	6,17	6,97	7,79	8,75	6,32	7,01	7,83
Sensible cooling capacity	(1)	kW	4,45	4,85	5,21	3,99	4,32	4,63	5,53	6,24	7,10	5,14	5,77	6,55
Total cooling capacity	(2)(E)	kW	5,53	5,99	6,35	4,99	5,38	5,71	6,68	7,41	8,24	6,03	6,63	7,33
Sensible cooling capacity	(2)(E)	kW	4,11	4,46	4,75	3,65	3,94	4,17	5,24	5,86	6,59	4,85	5,39	6,04
FCEER class	(E)		E											
Water flow	(1)	l/h	1008	1093	1169	915	990	1059	1197	1336	1501	1085	1202	1344
Water pressure drop	(1)(E)	kPa	15	17	19	18	21	24	11	13	16	17	20	24
Heating capacity	(3)(E)	kW	7,49	8,11	8,65	6,68	7,20	7,67	8,70	9,62	10,7	7,74	8,52	9,46
Water pressure drop	(3)(E)	kPa	12	14	15	15	17	19	9	10	13	13	16	20
Heating capacity	(4)(E)	kW	6,29	6,80	7,26	5,59	6,03	6,42	7,28	8,04	8,93	6,47	7,11	7,88
FCCOP class	(E)		E			E			D			E		
Water flow	(4)	l/h	1094	1183	1259	972	1048	1114	1264	1397	1551	1124	1236	1369
Water pressure drop	(4)(E)	kPa	14	17	18	17	19	22	10	12	14	15	17	21
Standard coil - number of rows			4			3			4			3		
Total sound power level		dB(A)	61	63	69	59	63	69	62	67	72	62	67	72
Inlet + radiated sound power level	(E)	dB(A)	56	60	66	56	60	66	60	64	70	60	64	70
Outlet sound power level	(E)	dB(A)	59	59	65	55	59	65	58	63	69	58	63	69
Heating capacity DF	(5)(E)	kW	5,21	5,45	5,65	5,25	5,51	5,72	6,99	7,44	7,94	7,02	7,47	7,99
Water flow DF	(5)	l/h	456	477	496	460	483	501	612	651	695	614	654	700
Water pressure drop DF	(5)(E)	kPa	10	11	12	12	13	14	20	22	25	8	9	10
Additional coil DF - number of rows			1			1			1			1		

(1) Water temperature 7°C / 12°C, air temperature dry bulb 27°C, wet bulb 19°C (47% relative humidity)

(2) According to EN1397:2015

(3) Inlet water temperature 50°C, water flow rate same as in cooling mode, air temperature 20°C

(4) Water temperature 45°C / 40°C, air temperature 20°C

(5) Water temperature 65°C / 55°C, air temperature 20°C

(E) EUROVENT certified data

Power supply 230-1-50 (V-ph-Hz)

RATED TECHNICAL DATA

UTN			22A			22D			30A			30D		
Speed			min	med	max	min	med	max	min	med	max	min	med	max
Rated air flow	(E)	m ³ /h	1438	1819	2218	1485	1898	2380	2073	2604	3175	2092	2641	3206
Available static pressure	(E)	Pa	31	50	75	30	50	78	32	50	74	31	50	74
Power input	(E)	W	370	535	750	370	535	750	870	1090	1300	870	1090	1300
Total cooling capacity	(1)	kW	9,58	11,7	13,8	8,79	10,6	12,6	13,8	16,4	19,0	12,5	14,9	17,2
Sensible cooling capacity	(1)	kW	7,14	8,85	10,6	6,73	8,28	9,98	10,2	12,5	14,8	9,48	11,5	13,5
Total cooling capacity	(2)(E)	kW	9,21	11,2	13,0	8,42	10,1	11,9	12,9	15,4	17,7	11,6	13,8	15,9
Sensible cooling capacity	(2)(E)	kW	6,77	8,31	9,83	6,36	7,74	9,23	9,37	11,4	13,5	8,61	10,4	12,2
FCEER class	(E)		E											
Water flow	(1)	l/h	1644	2010	2366	1509	1827	2163	2365	2823	3270	2145	2561	2953
Water pressure drop	(1)(E)	kPa	12	17	22	15	21	29	27	37	48	21	29	37
Heating capacity	(3)(E)	kW	11,7	14,1	16,4	10,8	13,0	15,3	16,5	19,7	22,9	15,2	18,0	20,8
Water pressure drop	(3)(E)	kPa	10	14	18	12	17	23	22	30	39	17	23	30
Heating capacity	(4)(E)	kW	9,73	11,7	13,7	9,06	10,8	12,7	13,7	16,4	19,0	12,7	15,0	17,3
FCCOP class	(E)		D			D			E			E		
Water flow	(4)	l/h	1689	2039	2380	1573	1884	2209	2389	2852	3311	2203	2617	3008
Water pressure drop	(4)(E)	kPa	10	14	19	14	19	25	23	32	41	18	25	31
Standard coil - number of rows			4			3			5			4		
Total sound power level		dB(A)	60	67	74	60	67	74	69	73	78	69	73	78
Inlet + radiated sound power level	(E)	dB(A)	58	65	72	58	65	72	67	71	76	67	71	76
Outlet sound power level	(E)	dB(A)	57	64	71	57	64	71	66	70	75	66	70	75
Heating capacity DF	(5)(E)	kW	10,6	12,3	13,9	10,9	12,6	14,4	14,8	17,0	19,2	14,9	17,2	19,3
Water flow DF	(5)	l/h	930	1077	1215	950	1105	1264	1295	1490	1680	1302	1503	1690
Water pressure drop DF	(5)(E)	kPa	6	8	10	6	8	10	13	16	20	12	17	21
Additional coil DF - number of rows			2			2			2			2		

UTN			40A			40D		
Speed			min	med	max	min	med	max
Rated air flow	(E)	m ³ /h	3067	3622	4287	3129	3706	4422
Available static pressure	(E)	Pa	36	50	71	35	50	71
Power input	(E)	W	650	820	1150	650	820	1150
Total cooling capacity	(1)	kW	18,0	20,4	23,2	16,1	18,2	20,7
Sensible cooling capacity	(1)	kW	14,0	16,1	18,6	12,7	14,6	16,8
Total cooling capacity	(2)(E)	kW	17,3	19,6	22,0	15,4	17,4	19,5
Sensible cooling capacity	(2)(E)	kW	13,3	15,3	17,5	12,1	13,8	15,6
FCEER class	(E)		D			E		
Water flow	(1)	l/h	3082	3505	3979	2761	3128	3551
Water pressure drop	(1)(E)	kPa	16	20	25	17	21	26
Heating capacity	(3)(E)	kW	22,4	25,4	28,7	20,5	23,1	26,0
Water pressure drop	(3)(E)	kPa	16	20	25	16	20	24
Heating capacity	(4)(E)	kW	18,8	21,2	24,0	17,2	19,4	21,8
FCCOP class	(E)		D					
Water flow	(4)	l/h	3263	3693	4177	2986	3364	3799
Water pressure drop	(4)(E)	kPa	18	22	28	18	23	28
Standard coil - number of rows			5			4		
Total sound power level		dB(A)	70	74	79	70	74	79
Inlet + radiated sound power level	(E)	dB(A)	68	72	77	68	72	77
Outlet sound power level	(E)	dB(A)	67	71	76	67	71	76
Heating capacity DF	(5)(E)	kW	18,3	20,2	22,2	18,5	20,4	22,6
Water flow DF	(5)	l/h	1601	1766	1948	1620	1790	1983
Water pressure drop DF	(5)(E)	kPa	9	11	13	9	11	13
Additional coil DF - number of rows			2			2		

(1) Water temperature 7°C / 12°C, air temperature dry bulb 27°C, wet bulb 19°C (47% relative humidity)

(2) According to EN1397:2015

(3) Inlet water temperature 50°C, water flow rate same as in cooling mode, air temperature 20°C

(4) Water temperature 45°C / 40°C, air temperature 20°C

(5) Water temperature 65°C / 55°C, air temperature 20°C

(E) EUROVENT certified data

Power supply 230-1-50 (V-ph-Hz)

DIMENSIONAL DRAWINGS

UTN 06 - 16

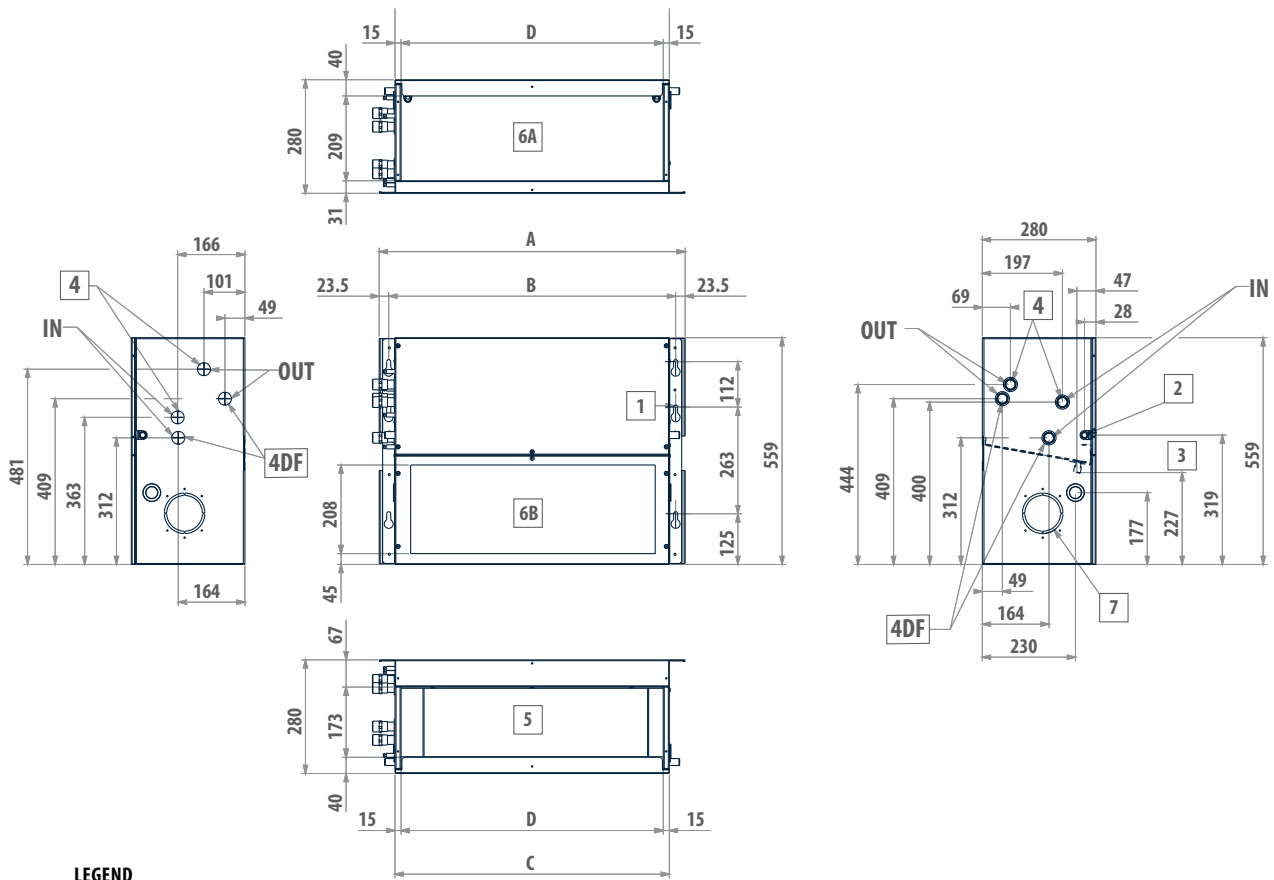

LEGEND

1	No. 6 quick-coupling slots
2	Condensate drainage horizontal installation
3	Condensate drainage vertical installation
4	Water connections on the right
4DF	Water connections additional heat exchanger
5	Air outlet
6	Air intake
6-A	supply condition
6-B	modifiable during installation
7	Circular pre-cut slot (\varnothing 100 mm) for intake of external air

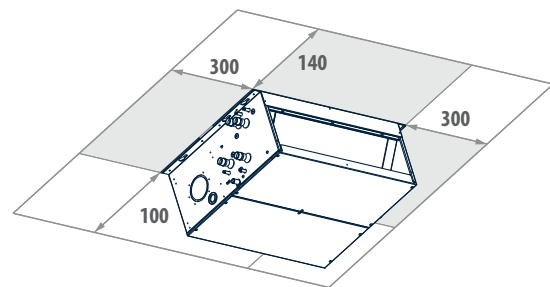

UTN	A mm	B mm	C mm	D mm	4 "	4DF "	2 mm	3 mm	kg
6D - 6A - 8D - 8A	754	707	676	646	3/4	3/4	17	17	33
12D - 12A	964	917	886	856	3/4	3/4	17	17	42
16D - 16A	1174	1127	1096	1066	3/4	3/4	17	17	49

MODELS 6 AND 6A AVAILABLE ON/OFF VERSION ONLY

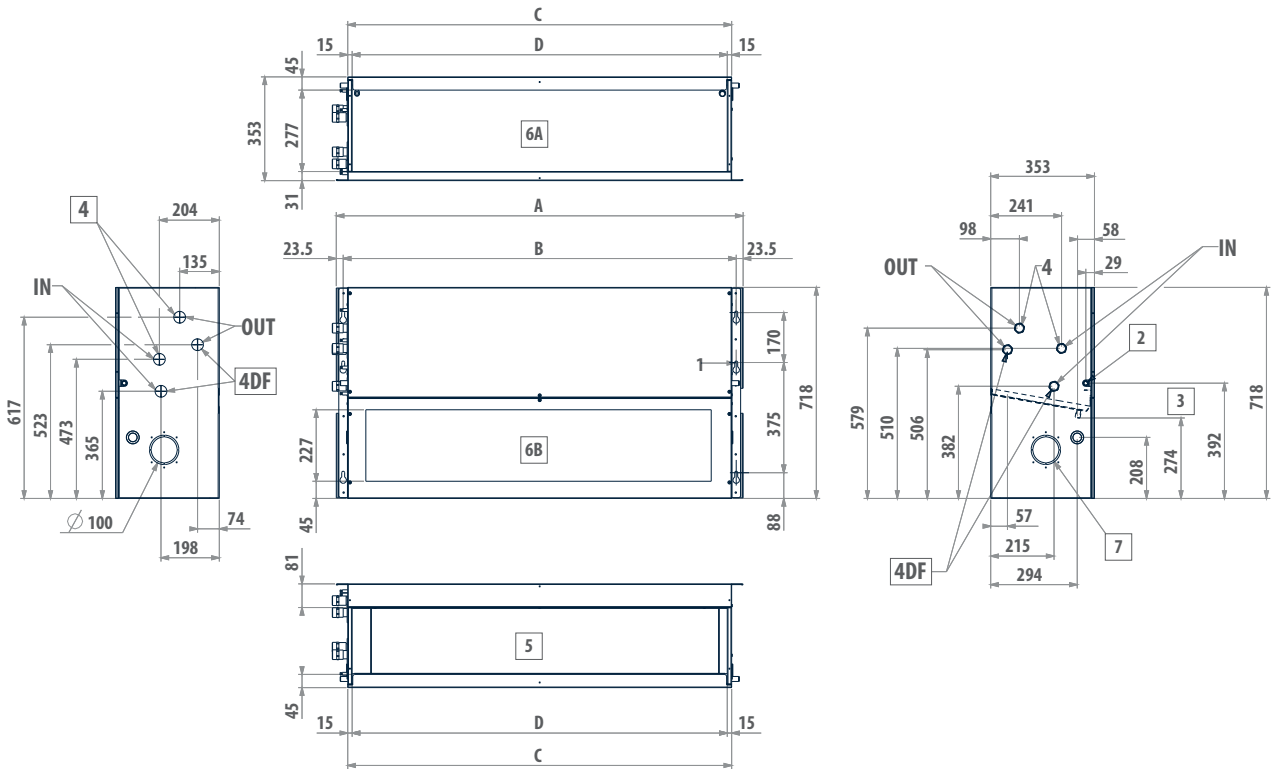
DIMENSIONAL DRAWINGS
UTN 22 - 40

LEGEND

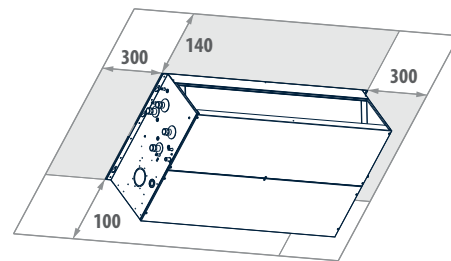
1	No. 6 quick-coupling slots
2	Condensate drainage horizontal installation
3	Condensate drainage vertical installation
4	Water connections on the right
4DF	Water connections additional heat exchanger
5	Air outlet
6	Air intake
6-A	supply condition
6-B	modifiable during installation
7	Circular pre-cut slot (Ø 100 mm) for intake of external air



UTN	A	B	C	D	4	4DF	2	3	kg
	mm	mm	mm	mm	"	"	mm	mm	
22D - 22A	1174	1127	1096	1066	1	1	17	17	67
30D - 30A	1384	1337	1306	1276	1	1	17	17	80
40D - 40A	1594	1547	1516	1486	1	1	17	17	90

High-head thermal ventilating units with BLDC motor

UTN i 4 - 10 kW

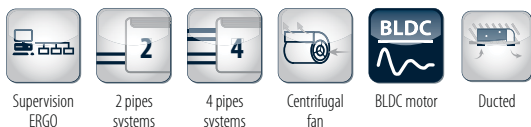

High efficiency and low noise emissions for ducted applications

The thermal ventilating units of the UTN i range with inverter motors and cooling capacities of 4 to 10 kW represent an evolution of the UTN series: keeping in pace with current legislation on energy savings and equipment efficiency and the most recent technological developments in the realm of electric motors, Galletti offers ducted units equipped with inverter-controlled permanent magnet BLDC motors. This solution makes it possible to reduce electricity consumption by up to 70% compared to a traditional asynchronous motor and at the same time offers the possibility of achieving a precise regulation of air flow, thanks to its ability to vary the number of fan revolutions in a continuous and efficient manner. The particular features which characterize the UTN series, namely, the height of 280 mm to enable the units to be accommodated in false ceilings, flexibility of installation and connection to air ducts and wide selection of accessories, are maintained to ensure the same standards of quality. Moreover, the availability of heat exchangers with a large number of rows makes it possible to use a low-temperature thermal carrier fluid in the heating mode, which means further energy savings.

PLUS

- » Permanent magnet BLDC motor
- » Low electricity consumption
- » Easy setup of ventilation section
- » Reduced height across the entire range (280 mm)
- » Vertical and horizontal installation
- » Wide range of available accessories
- » High flexibility of installation

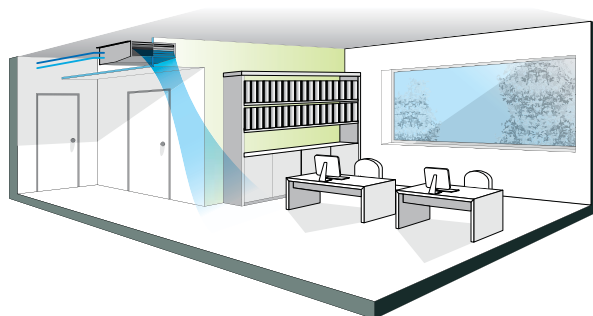

Comfort and quiet operation

Thanks to the possibility of regulating the rotation speed of the motor with high precision, UTN i is well-suited to interiors where keeping noise levels low is a must.

Available on request air decontamination system installed on special plenum.

AVAILABLE VERSIONS

UTXXXILO...0A Thermal ventilating unit suitable for 2-pipe systems

UTXXXILL...0A Thermal ventilating unit suitable for 4-pipe systems (2 heat exchangers)

UTXXXILO...02 The version with double panelling is made with pre-painted sheet steel insulated with class 0 fire-resistant rockwool **(On request)**

MAIN COMPONENTS

Structure

Made of galvanized sheet steel insulated with sound-deadening, heat-insulating, self-extinguishing closed-cell material to reduce noise emissions and prevent the formation of condensate on the outside surface.

Heat exchanger

It is composed of copper tubing and aluminium fins fixed by expansion. Water connections are reversible. An additional exchanger is available for installing the unit in 4-pipe systems.

Fan

The aluminium fans are of the centrifugal type, with double suction and staggered blades to reduce noise emissions. They are statically and dynamically balanced to minimize the stresses transmitted to the motor shaft.



BLDC electric motor

Permanent magnet motor. The unit is equipped with an inverter board to control the motor, that makes it possible to precisely set the maximum rotation speed of the motor (control signal 0-10 V).

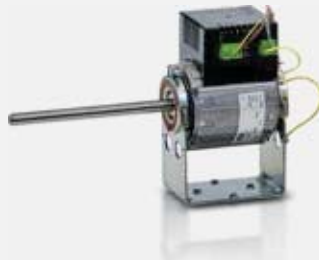

Condensate collection and drainage system

It consists of two insulated galvanized sheet steel trays designed for horizontal and vertical installation.

Filter module

The air filter, made of regenerable acrylic fibre, is available as an accessory in filtration classes G2 or G4.

ACCESSORIES

Electronic microprocessor control panels with display

DIST MY COMFORT controller spacer for wall mounting

EVOBOARD Circuit board for EVO control

EVODISP User interface with display for EVO controller

MCLE Microprocessor control with display MY COMFORT LARGE

MCSUE Humidity sensor for MY COMFORT (medium e large), EVO

MCSWE Water sensor for MYCOMFORT, EVO, LED 503 controllers

Electronic microprocessor control panels

TED 10 Electronic controller for BLDC fan equipped with inverter and ON/OFF valves 230 V

TED SWA Water temperature sensor for TED controls

Power interface and regulating louver controllers

CSD Recess mounted controller for opening and closing the SM motor-driven regulating louver

Auxiliary water drip trays, insulating shell, condensate drainage pump

KSC Condensate drainage pump kit

Electrical heating elements

RE Heating element with installation kit, relay box and safety devices

Air inlet and outlet grilles

GM Aluminium air outlet grille with 2-row fins and subframe

GR Air intake grille with subframe

GRF Air intake grille with subframe and filter

External air intake louvers

PA90 Motor-driven external air intake louver

Valves

V2VDF+STD 2-way valves, ON/OFF or MODULATING actuator, 230 V or 24 V power supply, hydraulic kit, for main and additional heat exchanger

V2VSTD 2-way valve, ON/OFF or MODULATING actuator, 230 V or 24 V power supply, hydraulic kit, for main heat exchanger

V3VDF 3-way valves, ON/OFF or MODULATING actuator, 230 V or 24 V power supply, hydraulic kit, for additional heat exchanger

V3VSTD 2-way valves, ON/OFF or MODULATING actuator, 230 V or 24 V power supply, hydraulic kit, for main heat exchanger

Plenum, air intake modules, air inlet and outlet connectors

G90 90° connection for intake/delivery

MAF Air intake module with G2 air filter

MAFO Air intake module with G4 air filter

PCOC Junction panel with rectangular duct

PCOF Junction panel with flexible circular duct Ø 200

Flexible ducts - caps

TFA Not insulated flexible ducts, Ø 200 mm (6 m length undivisible)

TFM Insulated flexible ducts, Ø 200 mm (6 m length undivisible)

TP Plastic cap Ø 200 mm

Air inlet and outlet plenum box

CA Air Inlet plenum box with double row grille

CAF Air Inlet plenum box with double row grille 300 x 600 mm and filter G2

CM Insulated air outlet plenum box with grille

Accessories

UYBP Hot water post-heating exchanger kit

VRCH Auxiliary water drip tray for horizontal installation units

VRCV Auxiliary water drip tray for vertical installation units

Vibration-damping couplings

GA Vibration-damping coupling

GAT Heat-resistant vibration-damping coupling

RATED TECHNICAL DATA

UTN i			8A			8D			12A			12D		
Speed			min	med	max	min	med	max	min	med	max	min	med	max
Control voltage		V	6,00	7,40	8,90	6,00	7,40	8,90	7,30	8,00	8,80	7,30	8,00	8,80
Rated air flow	(E)	m ³ /h	531	692	792	534	700	802	998	1107	1206	1021	1134	1241
Available static pressure	(E)	Pa	30	50	65	29	50	65	41	50	59	41	50	59
Power input	(E)	W	40	73	112	40	73	112	102	125	152	102	125	152
Total cooling capacity	(1)	kW	3,42	4,27	4,76	2,87	3,54	3,91	5,87	6,37	6,81	5,33	5,77	6,17
Sensible cooling capacity	(1)	kW	2,58	3,26	3,68	2,23	2,77	3,09	4,45	4,85	5,21	3,99	4,32	4,63
Total cooling capacity	(2)(E)	kW	3,38	4,20	4,65	2,83	3,47	3,80	5,77	6,25	6,66	5,23	5,64	6,02
Sensible cooling capacity	(2)(E)	kW	2,54	3,19	3,57	2,19	2,70	2,98	4,35	4,72	5,06	3,89	4,20	4,48
FCEER class	(E)		B			C			C			C		
Water flow	(1)	l/h	587	732	817	493	607	671	1008	1093	1169	915	990	1059
Water pressure drop	(1)(E)	kPa	8	12	14	10	14	17	15	17	19	18	21	24
Heating capacity	(3)(E)	kW	4,24	5,22	5,79	3,63	4,41	4,85	7,49	8,11	8,65	6,68	7,20	7,67
Water pressure drop	(3)(E)	kPa	7	10	12	8	12	14	12	14	15	15	17	19
Heating capacity	(4)(E)	kW	3,55	4,36	4,83	3,04	3,69	4,05	6,29	6,80	7,26	5,59	6,03	6,42
FCCOP class	(E)		A			B			B			B		
Water flow	(4)	l/h	617	758	840	529	641	705	1094	1183	1259	972	1048	1114
Water pressure drop	(4)(E)	kPa	7	11	13	9	13	15	14	17	18	17	19	22
Standard coil - number of rows			4			3			4			3		
Total sound power level		dB(A)	54	61	66	54	61	66	61	63	69	59	63	69
Inlet + radiated sound power level	(E)	dB(A)	52	59	64	52	59	64	56	60	66	56	60	66
Outlet sound power level	(E)	dB(A)	51	58	63	51	58	63	59	59	65	55	59	65
Heating capacity DF	(5)(E)	kW	3,23	3,66	3,89	3,23	3,68	3,91	5,21	5,45	5,65	5,25	5,51	5,72
Water flow DF	(5)	l/h	283	320	340	283	322	342	456	477	496	460	483	501
Water pressure drop DF	(5)(E)	kPa	5	6	7	5	6	7	10	11	12	12	13	14
Additional coil DF - number of rows			1			1			1			1		

(1) Water temperature 7°C / 12°C, air temperature dry bulb 27°C, wet bulb 19°C (47% relative humidity)

(2) According to EN1397:2015

(3) Inlet water temperature 50°C, water flow rate same as in cooling mode, air temperature 20°C

(4) Water temperature 45°C / 40°C, air temperature 20°C

(5) Water temperature 65°C / 55°C, air temperature 20°C

(E) EUROVENT certified data

Power supply 230-1-50 (V-ph-Hz)

NOTE: The dimensional drawings of the UTN i inverter units are the same of the UTN ON/OFF version. They are reported from page 114

RATED TECHNICAL DATA

UTN i			16A			16D		
Speed			min	med	max	min	med	max
Control voltage		V	6,70	7,70	8,90	6,70	7,70	8,90
Rated air flow	(E)	m ³ /h	1200	1371	1584	1208	1384	1609
Available static pressure	(E)	Pa	38	50	66	38	50	67
Power input	(E)	W	124	170	248	124	170	248
Total cooling capacity	(1)	kW	6,97	7,79	8,75	6,32	7,01	7,83
Sensible cooling capacity	(1)	kW	5,53	6,24	7,10	5,14	5,77	6,55
Total cooling capacity	(2)(E)	kW	6,85	7,62	8,50	6,20	6,84	7,58
Sensible cooling capacity	(2)(E)	kW	5,41	6,07	6,85	5,02	5,60	6,30
FCEER class	(E)		C					
Water flow	(1)	l/h	1197	1336	1501	1085	1202	1344
Water pressure drop	(1)(E)	kPa	11	13	16	17	20	24
Heating capacity	(3)(E)	kW	8,70	9,62	10,7	7,74	8,52	9,46
Water pressure drop	(3)(E)	kPa	9	10	13	13	16	20
Heating capacity	(4)(E)	kW	7,28	8,04	8,93	6,47	7,11	7,88
FCCOP class	(E)		B			C		
Water flow	(4)	l/h	1264	1397	1551	1124	1236	1369
Water pressure drop	(4)(E)	kPa	10	12	14	15	17	21
Standard coil - number of rows			4			3		
Total sound power level		dB(A)	62	67	72	62	67	72
Inlet + radiated sound power level	(E)	dB(A)	60	64	70	60	64	70
Outlet sound power level	(E)	dB(A)	58	63	69	58	63	69
Heating capacity DF	(5)(E)	kW	6,99	7,44	7,94	7,02	7,47	7,99
Water flow DF	(5)	l/h	612	651	695	614	654	700
Water pressure drop DF	(5)(E)	kPa	20	22	25	8	9	10
Additional coil DF - number of rows			1			1		

(1) Water temperature 7°C / 12°C, air temperature dry bulb 27°C, wet bulb 19°C (47% relative humidity)

(2) According to EN1397:2015

(3) Inlet water temperature 50°C, water flow rate same as in cooling mode, air temperature 20°C

(4) Water temperature 45°C / 40°C, air temperature 20°C

(5) Water temperature 65°C / 55°C, air temperature 20°C

(E) EUROVENT certified data

Power supply 230-1-50 (V-ph-Hz)

NOTE: The dimensional drawings of the UTN i inverter units are the same of the UTN ON/OFF version. They are reported from page 114



FAN HEATERS

AREO	p. 122
AREO i	p. 132
DST	p. 136

Air conditioning fan heaters with ON/OFF motor

AREO 8 - 101 kW



Hygrothermal comfort in the industrial and commercial sectors

In line with recent regulatory developments regarding energy efficiency, Galletti is updating its offering of fan heaters for heating and cooling systems to be used in industrial and commercial environments of any volume. The new AREO, which was designed to meet the stringent requirements of the ERP Directive, retains unchanged the distinctive aspects of the original design, that is, extreme reliability and sturdiness.

AREO's cover, which is made of pre-painted steel sheet, possesses an original design with a rounded shape that enhances its aesthetic form.

The AREO range consists of 18 models that, limited to the only heating version, can be either wall mounted (horizontal air flow) or ceiling mounted (vertical air flow). The cooling version is equipped with a new system in order to collect condensation and further insulation inside the cover.

The units are available in 6 sizes with 2-, 3- or 4-row heat exchangers ensuring an efficient performance with hot water supplied by a boiler or heat pump (4-row models).



2 pipes systems



Vertical installation



Horizontal installation (not for AREO C)



Heating



Cooling (only for AREO C)

PLUS

- » Low sound levels
- » Wide operating range (up to 60 °C intake air)
- » Axial fan with blades with an aerodynamic profile (HyBlade® technology)
- » Electric motor, class F, approved for continuous operation
- » Wide operating range (up to 60 °C intake air)



AVAILABLE VERSIONS

Single-phase and three-phase power supply.

AREO P

Fan heaters for hot water heating, with side water connections.

AREO H

Fan heaters for hot water heating, with vertical water connections, for replacement of indoor units installed in existing systems.

AREO S

Fan heaters for steam heating, with vertical water connections.

AREO L

Fan heaters for hot water heating, equipped with air-curtain diffuser, ceiling mounted.

AREO C

Single phase power supplied fan heaters suitable either for heating or cooling mode, equipped with asynchronous electric motor and side water connections, wall mounted.

MAIN COMPONENTS
Fan drive assembly

The motor and fan are a single integrated unit optimized to achieve maximum aerodynamic efficiency. In fact, conformity to ERP2017 is guaranteed, even for the versions with single-phase power supply.

Electric motor

Tropicalized motor directly coupled to an external rotor, standard, with the following features:

- equipped with internal thermal protection
- windings in class F
- protection rating IP54
- maintenance-free ball bearings

Axial fan

With blades with an optimized aerodynamic profile (HyBlade® technology), statically balanced, inserted in a housing that enhances aerodynamic performance and minimizes noise.

Cabinet

Made of pre-painted steel sheet, complete with ABS corners, and manually adjustable aluminum baffles located on the air outlet for optimum distribution in the room to be heated.

Safety cage

Made of electrogalvanized steel wire, it supports the motor and is fixed to the cabinet by means of vibration-damping supports.

Heat exchanger

Made of copper pipes and aluminum fins of high thermal conductivity to optimize heat exchange.

RVM regulator for ventilation speed adjustment in single phase power supplied models

The speed regulator RVM can vary the effective value on the load by controlling the wave shape caused by a TRIAC. This accessory can be used only coupled to single phase power supplied models, and allows a fan heater manual ventilation speed adjustment depending on different needs. The device is also equipped with special filters in order to suppress noise induced on the supplied line or irradiated from the equipment and a minimum speed manually adjustable trimmer. This accessory is yet included with AREO C cooling series.

ACCESSORIES
Electromechanical control panels

CST	Delta/star switch for installation in electrical box
CSTP	Delta/star switch with box wall mounted
RVM	RVM manual power regulator for monophase power supply FAN HEATERS
TA	Wall-mounted room thermostat
TA2	Electromechanical room thermostat with summer/winter selection

Power interface and regulating louver controllers

CSD	Recess mounted controller for opening and closing the SM motor-driven regulating louver
------------	---

Accessories

VA	Auxiliary tray for collecting condensate
-----------	--

Fixation templates

DFC	Template for column installation
------------	----------------------------------

DFO	Adjustable template for wall/column installation
------------	--

DFP	Template for wall installation
------------	--------------------------------

Protective grill for gyms (ball shield)

R	Protective net for gyms
----------	-------------------------

Diffusers

DO	Two-row adjustable fin diffuser
LA	Air curtain diffuser

External air intake

PAE	External air intake
PAEM	Manual mixing louver
PAEMM	Motor driven mixer louver, 24 V power supply with spring return

External air intake rain protection grille

GR	Air intake grille with subframe
-----------	---------------------------------

RATED TECHNICAL DATA AREO P - HEATING MODE

AREO P			12	12	13	13	14	14	
Power supply		V-ph-Hz	230 - 1 - 50						
no. of poles			4	6	4	6	4	6	
Motor connctions			Mono	Mono	Mono	Mono	Mono	Mono	
Rated air flow		m³/h	1280	1000	1140	900	1040	800	
Heating capacity	(1)	kW	9,77	8,48	12,4	10,7	14,2	11,9	
Water flow	(1)	l/h	863	749	1097	946	1252	1047	
Water pressure drop	(1)	kPa	29	23	22	17	17	12	
Sound power level	(2)	dB(A)	64	59	64	59	65	60	
Power input		W	69	49	69	50	70	51	

AREO P			22	22	23	23	24	24	
Power supply		V-ph-Hz	230 - 1 - 50						
no. of poles			4	6	4	6	4	6	
Motor connctions			Mono	Mono	Mono	Mono	Mono	Mono	
Rated air flow		m³/h	3020	2100	2630	1850	2600	1800	
Heating capacity	(1)	kW	19,9	16,2	25,6	20,6	28,9	22,9	
Water flow	(1)	l/h	1754	1432	2256	1820	2555	2022	
Water pressure drop	(1)	kPa	23	16	29	20	19	13	
Sound power level	(2)	dB(A)	76	64	76	65	77	65	
Power input		W	198	110	210	114	212	120	

AREO P			32	32	32	33	33	33
Power supply		V-ph-Hz	230 - 1 - 50	400 - 3 - 50	400 - 3 - 50	230 - 1 - 50	400 - 3 - 50	400 - 3 - 50
no. of poles			4	4	6	4	4	6
Motor connctions			Mono	Delta	Star	Mono	Delta	Star
Rated air flow		m³/h	4500	4300	3200	4150	4000	2900
Heating capacity	(1)	kW	35,6	34,7	29,2	39,5	38,6	31,8
Water flow	(1)	l/h	3143	3060	2579	3486	3411	2806
Water pressure drop	(1)	kPa	20	19	14	18	17	12
Sound power level	(2)	dB(A)	76	76	69	76	76	69
Power input		W	320	315	175	340	330	180

AREO P			34	34	34	42	42	42
Power supply		V-ph-Hz	230 - 1 - 50	400 - 3 - 50	400 - 3 - 50	230 - 1 - 50	400 - 3 - 50	400 - 3 - 50
no. of poles			4	4	6	4	4	6
Motor connctions			Mono	Delta	Star	Mono	Delta	Star
Rated air flow		m³/h	4050	3900	2800	6900	7100	5600
Heating capacity	(1)	kW	45,1	44,0	35,6	53,4	54,3	47,4
Water flow	(1)	l/h	3980	3886	3145	4718	4793	4185
Water pressure drop	(1)	kPa	29	28	19	37	38	30
Sound power level	(2)	dB(A)	77	77	70	75	73	67
Power input		W	345	340	182	623	650	450

AREO P			43	43	43	44	44	44
Power supply		V-ph-Hz	230 - 1 - 50	400 - 3 - 50	400 - 3 - 50	230 - 1 - 50	400 - 3 - 50	400 - 3 - 50
no. of poles			4	4	6	4	4	6
Motor connctions			Mono	Delta	Star	Mono	Delta	Star
Rated air flow		m³/h	6400	6550	5300	6200	6400	5150
Heating capacity	(1)	kW	59,6	60,4	53,2	66,8	68,1	59,5
Water flow	(1)	l/h	5259	5329	4695	5894	6009	5250
Water pressure drop	(1)	kPa	36	37	30	23	24	19
Sound power level	(2)	dB(A)	74	74	68	75	75	69
Power input		W	635	690	465	655	700	470

- (1) Water temperature 85°C / 75°C, air temperature 15°C - 100% of the max speed
(2) Sound power measured according to standards ISO 3741 - 100% of the max speed

RATED TECHNICAL DATA AREO P - HEATING MODE

AREO P			52	52	52	53	53	53
Power supply		V-ph-Hz	230 - 1 - 50	400 - 3 - 50	400 - 3 - 50	230 - 1 - 50	400 - 3 - 50	400 - 3 - 50
no. of poles			6	4	6	6	4	6
Motor connections			Mono	Delta	Star	Mono	Delta	Star
Rated air flow		m ³ /h	6400	8200	6800	6200	7900	6450
Heating capacity	(1)	kW	48,6	55,9	50,3	60,8	70,2	62,3
Water flow	(1)	l/h	4294	4934	4445	5373	6202	5497
Water pressure drop	(1)	kPa	17	22	18	19	25	20
Sound power level	(2)	dB(A)	69	75	71	69	76	72
Power input		W	370	725	760	374	732	775

AREO P			54	54	54	62	62	62
Power supply		V-ph-Hz	230 - 1 - 50	400 - 3 - 50	400 - 3 - 50	230 - 1 - 50	400 - 3 - 50	400 - 3 - 50
no. of poles			6	4	6	6	6	8
Motor connections			Mono	Delta	Star	Mono	Delta	Star
Rated air flow		m ³ /h	5900	7600	6200	8600	8900	7100
Heating capacity	(1)	kW	66,2	77,4	68,3	85,7	87,5	76,2
Water flow	(1)	l/h	5852	6834	6033	7567	7722	6731
Water pressure drop	(1)	kPa	21	27	22	21	22	17
Sound power level	(2)	dB(A)	71	77	73	70	71	66
Power input		W	380	755	780	555	565	360

AREO P			63	63	63	64	64	64
Power supply		V-ph-Hz	230 - 1 - 50	400 - 3 - 50	400 - 3 - 50	230 - 1 - 50	400 - 3 - 50	400 - 3 - 50
no. of poles			6	6	8	6	6	8
Motor connections			Mono	Delta	Star	Mono	Delta	Star
Rated air flow		m ³ /h	7695	8300	6500	7500	7650	6000
Heating capacity	(1)	kW	79,3	101	86,4	99,6	101	85,8
Water flow	(1)	l/h	7002	8943	7626	8795	8913	7571
Water pressure drop	(1)	kPa	18	30	23	29	29	22
Sound power level	(2)	dB(A)	69	72	67	71	72	67
Power input		W	560	575	380	582	590	390

- (1) Water temperature 85°C / 75°C, air temperature 15°C - 100% of the max speed
 (2) Sound power measured according to standards ISO 3741 - 100% of the max speed

RATED TECHNICAL DATA AREO C - HEATING MODE

AREO C			12	12	13	13	14	14	22	22	23
Power supply		V-ph-Hz	230 - 1 - 50								
no. of poles			4	6	4	6	4	6	4	6	4
Air flow rate max heating		m ³ /h	1280	1000	1140	900	1040	800	3020	2100	2630
Heating capacity	(1)	kW	9,77	8,48	12,4	10,7	14,2	11,9	19,9	16,2	25,6
Water flow	(1)	l/h	863	749	1097	946	1252	1047	1754	1432	2256
Water pressure drop	(1)	kPa	29	23	22	17	17	12	23	16	29
Sound power level	(2)	dB(A)	64	59	64	59	65	60	76	64	76
Power input	(3)	W	67	49	69	50	70	51	198	110	210

AREO C			23	24	24	32	33	34	42	43	44
Power supply		V-ph-Hz	230 - 1 - 50								
no. of poles			6	4	6	4	4	4	4	4	4
Air flow rate max heating		m ³ /h	1850	2600	1800	4500	4150	4050	6900	6400	6200
Heating capacity	(1)	kW	20,6	28,9	22,9	35,6	39,5	45,1	53,4	59,6	66,8
Water flow	(1)	l/h	1820	2555	2022	3143	3486	3980	4718	5259	5894
Water pressure drop	(1)	kPa	20	19	13	20	18	29	37	36	23
Sound power level	(2)	dB(A)	65	77	65	76	76	77	75	74	75
Power input	(3)	W	114	212	120	320	340	345	623	635	655

AREO C			52	53	54	62	63	64
Power supply		V-ph-Hz	230 - 1 - 50					
no. of poles			6	6	6	6	6	6
Air flow rate max heating		m ³ /h	6400	6200	5900	8600	7695	7500
Heating capacity	(1)	kW	48,6	60,8	66,3	85,7	79,3	99,6
Water flow	(1)	l/h	4294	5373	5852	7567	8802	8795
Water pressure drop	(1)	kPa	17	19	21	21	29	29
Sound power level	(2)	dB(A)	69	69	71	70	69	71
Power input	(3)	W	370	374	380	555	560	582

- (1) Water temperature 85°C / 75°C, air temperature 15°C - 100% of the max speed
 (2) Sound power measured according to standards ISO 3741 - 100% of the max speed
 (3) Measured at 100% of the max speed

RATED TECHNICAL DATA AREO C - COOLING MODE

AREO C			12	12	13	13	14	14	22	22	23
Power supply		V-ph-Hz	230 - 1 - 50								
no. of poles			4	6	4	6	4	6	4	6	4
Air flow rate max cooling		m ³ /h	898	898	808	808	718	718	1602	1602	1411
Heating capacity	(1)	kW	7,87	7,87	10,0	10,0	11,2	11,2	13,4	13,4	17,3
Water flow	(1)	l/h	695	695	884	884	988	988	1184	1184	1527
Water pressure drop	(1)	kPa	18	18	13	13	10	10	9	9	15
Total cooling capacity	(2)	kW	2,30	2,30	2,82	2,82	3,15	3,15	3,61	3,61	5,00
Sensible cooling capacity	(2)	kW	1,81	1,81	2,23	2,23	2,45	2,45	3,08	3,08	3,91
Water flow	(2)	l/h	395	395	482	482	541	541	620	620	860
Water pressure drop	(2)	kPa	9	9	6	6	5	5	4	4	7
Sound power level	(3)	dB(A)	53	54	53	54	54	55	58	59	63
Power input	(4)	W	33	34	33	34	33	34	95	81	95

AREO C			23	24	24	32	33	34	42	43	44
Power supply		V-ph-Hz	230 - 1 - 50								
no. of poles			6	4	6	4	4	4	4	4	4
Air flow rate max cooling		m ³ /h	1411	1373	1373	2485	2292	2237	3738	3467	3359
Heating capacity	(1)	kW	17,3	19,1	19,1	22,9	25,4	29,1	35,1	39,2	43,9
Water flow	(1)	l/h	1527	1686	1686	2024	2242	2569	3098	3460	3875
Water pressure drop	(1)	kPa	15	5	5	5	5	8	7	7	3
Total cooling capacity	(2)	kW	5,00	5,23	5,23	5,72	7,22	9,65	9,72	12,4	13,1
Sensible cooling capacity	(2)	kW	3,91	4,20	4,20	5,23	6,12	7,50	7,85	8,69	10,3
Water flow	(2)	l/h	860	898	898	982	1239	1656	1668	2123	2255
Water pressure drop	(2)	kPa	7	2	2	1	1	4	2	3	1
Sound power level	(3)	dB(A)	60	59	60	63	63	64	62	61	62
Power input	(4)	W	81	95	81	153	153	153	400	400	400

AREO C			52	53	54	62	63	64
Power supply		V-ph-Hz	230 - 1 - 50					
no. of poles			6	6	6	6	6	6
Air flow rate max cooling		m ³ /h	3072	3001	2832	4730	4232	4125
Heating capacity	(1)	kW	31,1	38,6	42,4	55,7	48,0	64,7
Water flow	(1)	l/h	2745	3406	3743	4197	4240	5715
Water pressure drop	(1)	kPa	10	11	11	8	8	8
Total cooling capacity	(2)	kW	8,92	10,5	14,8	14,5	18,9	22,4
Sensible cooling capacity	(2)	kW	7,64	8,50	11,4	12,4	14,3	16,8
Water flow	(2)	l/h	1304	1800	2022	2490	3237	3853
Water pressure drop	(2)	kPa	4	5	6	2	4	4
Sound power level	(3)	dB(A)	53	53	55	57	56	58
Power input	(4)	W	272	272	272	335	335	335

(1) Water temperature 85°C / 75°C, air temperature 15°C - max speed available in cooling mode

(2) Water temperature 7°C / 12°C, air temperature dry bulb 27°C, wet bulb 19°C (47% relative humidity) - max speed available in cooling mode

(3) Sound power measured according to standards ISO 3741 - max speed available in cooling mode

(4) Measured at max speed available in cooling mode

All data reported in the table above refer to maximum allowed ventilation speed in order to avoid the drag of the condensation drops generated in the heat exchanger.

RATED TECHNICAL DATA AREO H - HEATING MODE

AREO H			13	13	23	23	33	33	33	43
Power supply		V-ph-Hz	230 - 1 - 50	230 - 1 - 50	230 - 1 - 50	230 - 1 - 50	230 - 1 - 50	400 - 3 - 500	400 - 3 - 500	230 - 1 - 50
no. of poles			4	6	4	6	4	4	6	4
Motor connections			Mono	Mono	Mono	Mono	Mono	Delta	Star	Mono
Rated air flow		m ³ /h	1083	855	2499	1758	3943	3800	2755	6080
Heating capacity	(1)	kW	10,2	8,89	21,3	17,3	33,2	32,5	26,9	50,4
Water flow	(1)	l/h	905	785	1882	1529	2935	2871	2376	4454
Water pressure drop	(1)	kPa	13	10	19	13	12	11	8	25
Sound power level	(2)	dB(A)	64	59	76	65	74	76	69	75
Power input		W	69	50	210	114	340	330	180	635

(1) Water temperature 85°C / 75°C, air temperature 15°C - 100% of the max speed

(2) Sound power measured according to standards ISO 3741 - 100% of the max speed

AREO H			43	43	53	53	53	63	63	63
Power supply		V-ph-Hz	400 - 3 - 500	400 - 3 - 500	230 - 1 - 50	400 - 3 - 500	400 - 3 - 500	230 - 1 - 50	400 - 3 - 500	400 - 3 - 500
no. of poles			4	6	6	4	6	6	6	8
Motor connections			Delta	Star	Mono	Delta	Star	Mono	Delta	Star
Rated air flow		m ³ /h	6223	5035	5890	7505	6128	8100	7885	6175
Heating capacity	(1)	kW	51,1	45,2	56,2	64,8	57,5	99,7	80,5	69,2
Water flow	(1)	l/h	4512	3991	4960	5720	5079	8802	7106	6112
Water pressure drop	(1)	kPa	25	20	16	20	16	29	19	15
Sound power level	(2)	dB(A)	77	70	69	76	72	70	71	66
Power input		W	690	465	375	732	775	560	575	380

(1) Water temperature 85°C / 75°C, air temperature 15°C - 100% of the max speed

(2) Sound power measured according to standards ISO 3741 - 100% of the max speed

DIMENSIONAL DRAWINGS

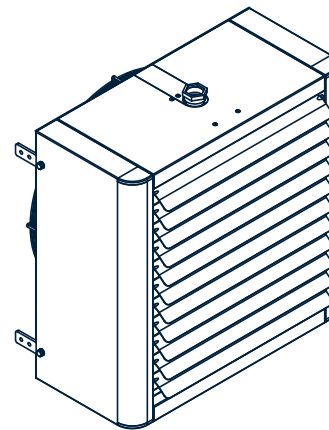
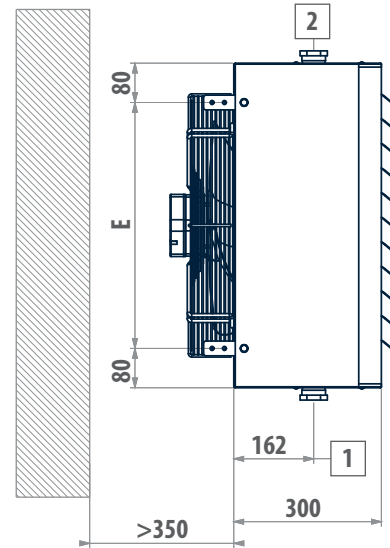
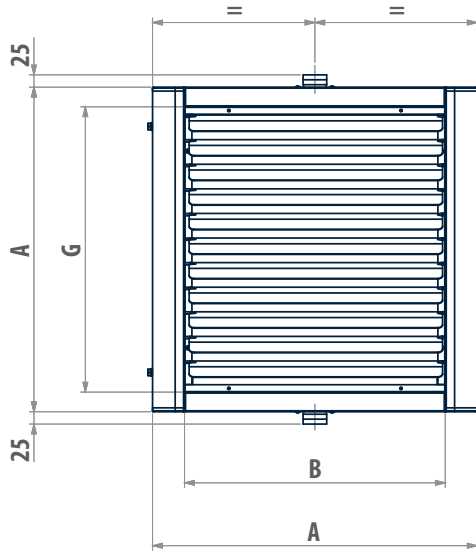
AREO H - AREO S

LEGEND

- | | |
|---|------------------------------------|
| 1 | Water inlet connection female gas |
| 2 | Water outlet connection female gas |

AREO H	A mm	B mm	E mm	G mm	1 "	2 "	 kg
13	460	330	300	380	1 1/4	1 1/4	20
23	560	430	400	480	1 1/4	1 1/4	26
33	660	530	500	580	1 1/4	1 1/4	35
43	760	630	600	680	1 1/4	1 1/4	41
53	860	730	700	780	1 1/4	1 1/4	52
63	960	830	800	880	1 1/4	1 1/4	61

AREO S	A mm	B mm	E mm	G mm	1 "	2 "	 kg
12	460	330	300	380	1 1/4	1 1/4	20
22	560	430	400	480	1 1/4	1 1/4	26
32	660	530	500	580	1 1/4	1 1/4	35
42	760	630	600	680	1 1/4	1 1/4	41
52	860	730	700	780	1 1/4	1 1/4	52
62	960	830	800	880	1 1/4	1 1/4	61

DIMENSIONAL DRAWINGS

AREO P - AREO L

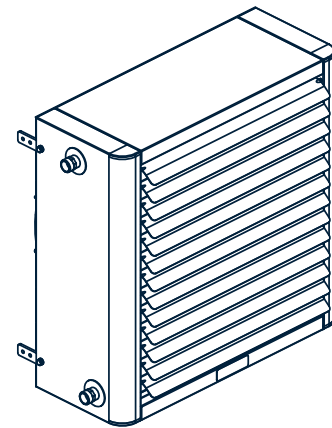
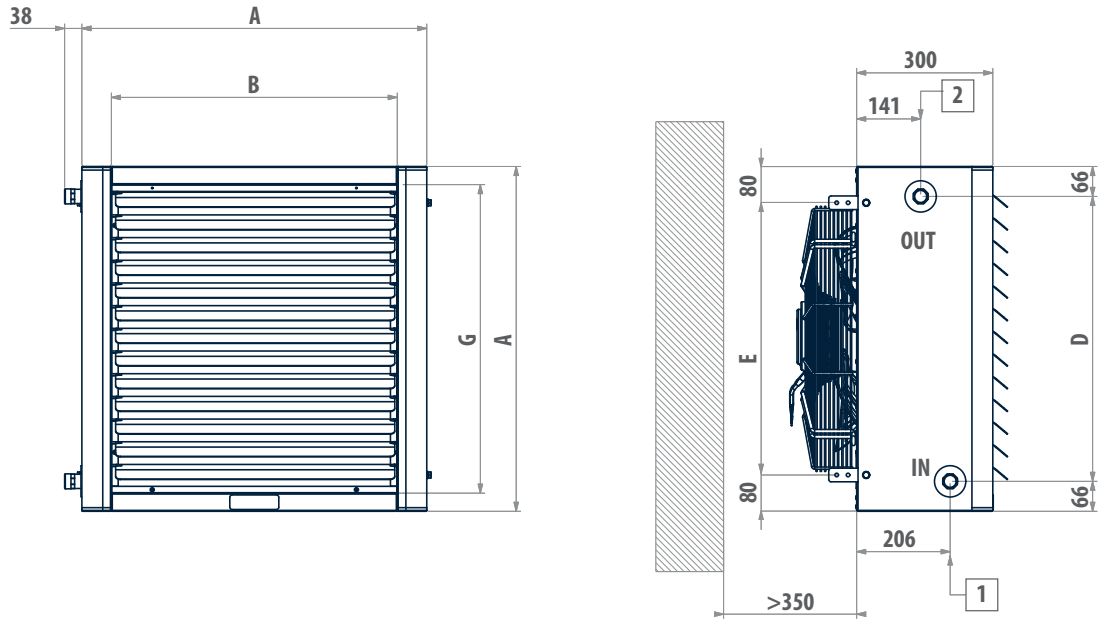

LEGEND

- 1 Water inlet connection male gas
- 2 Water outlet connection male gas

AREO P	A	B	D	E	G	1	2	kg
	mm	mm	mm	mm	mm	"	"	
12 - 13 - 14	460	330	300	380	380	3/4	3/4	20-20-21
22 - 23 - 24	560	430	400	480	480	3/4	3/4	26-26-27
32 - 33 - 34	660	530	500	580	580	1	1	34-35-37
42 - 43 - 44	760	630	600	680	680	1	1	40-41-44
52 - 53 - 54	860	730	700	780	780	1 1/4	1 1/4	50-52-55
62 - 63 - 64	960	830	800	880	880	1 1/4	1 1/4	58-61-64

AREO L	A	B	D	E	G	1	2	kg
	mm	mm	mm	mm	mm	"	"	
32 - 33	660	530	500	580	580	1	1	34-35
42 - 43	760	630	600	680	680	1	1	40-41
52 - 53	860	730	700	780	780	1 1/4	1 1/4	50-52
62 - 63	960	830	800	880	880	1 1/4	1 1/4	58-61

DIMENSIONAL DRAWINGS

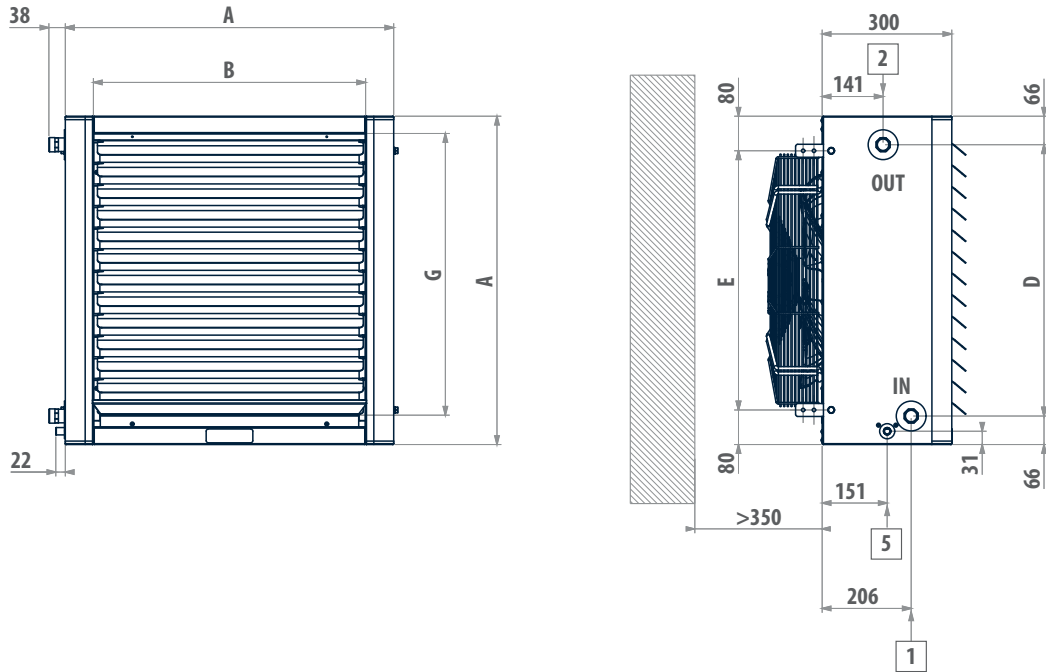
AREO C

LEGEND

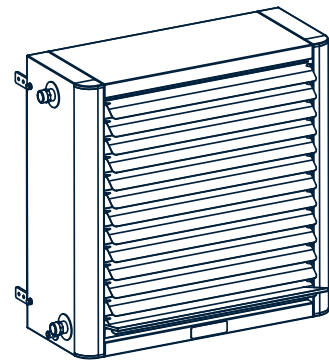
- | | |
|---|---|
| 1 | Water inlet connection male gas |
| 2 | Water outlet connection male gas |
| 5 | Condensate drainage \varnothing 17 mm |



AREO C	A mm	B mm	D mm	E mm	G mm	1 "	2 "	kg
12 - 13 - 14	460	330	300	380	380	3/4	3/4	20-20-21
22 - 23 - 24	560	430	400	480	480	3/4	3/4	26-26-27
32 - 33 - 34	660	530	500	580	580	1	1	34-35-37
42 - 43 - 44	760	630	600	680	680	1	1	40-41-44
52 - 53 - 54	860	730	700	780	780	1 1/4	1 1/4	50-52-55
62 - 63 - 64	960	830	800	880	880	1 1/4	1 1/4	58-61-64

Air conditioning fan heaters with BLDC motor

AREO i 11 - 118 kW



Reliability and energy efficiency at the top of its category

The new AREO i series combines the reliability and sturdiness of the on/off version with the innovation of EBM-PAPST GreenTech® technology. The AREO i series is equipped with brushless inverters (BLDC) integrated with the motor, which guarantees accurate adjustment of the rotation speed and maximum adaptability to real-time thermal load

Innovative GreenTech® technology makes it possible to achieve an exceptional degree of aerodynamic efficiency and a consequent reduction in seasonal power consumption of up to 50% in comparison to the traditional version with AC motor.

The rounded shape of the cabinet gives the product an especially unique design.

The AREO i range consists of 18 models to be wall mounted. AREO i is ideal for both mode heating and cooling due to an innovative system for collecting condensate and additional insulation inside the cabinet.

The range includes 6 different construction sizes that are also available with 4-row heat exchangers to allow proper operation with hot water produced by the heat pump.

PLUS

- » Low sound levels
- » Wide operating range (up to 65 °C intake air)
- » Axial fan with blades with an aerodynamic profile (HyBlade® technology)
- » Electric motor, class F, approved for continuous operation
- » Fan and motor are integrated to provide considerably increased reliability



ACCESSORIES

Electronic microprocessor control panels with display

DIST MY COMFORT controller spacer for wall mounting

MCLE Microprocessor control with display MY COMFORT LARGE

MCSWE Water sensor for MYCOMFORT, EVO, LED 503 controllers

Power interface and regulating louver controllers

CSD Recess mounted controller for opening and closing the SM motor-driven regulating louver

Accessories

VA Auxiliary tray for collecting condensate

Fixation templates

DFC Template for column installation

DFO Adjustable template for wall/column installation

DFP Template for wall installation

Protective grill for gyms (ball shield)

R Protective net for gyms

Diffusors

DO Two-row adjustable fin diffuser

External air intake

PAE External air intake

PAEM Manual mixing louver

PAEMM Motor driven mixer louver, 24 V power supply with spring return

External air intake rain protection grille

GR Air intake grille with subframe

MAIN COMPONENTS
Fan drive assembly

The electric fan and BLDC motor are a single integrated unit optimized to achieve maximum aeraulic efficiency. In fact, conformity to ERP2017 is guaranteed, even for the versions with single-phase power supply.

Electric motor

Tropicalized motor directly coupled to an external rotor, standard, with the following features:

- equipped with internal thermal protection
- windings in class F
- protection rating IP54
- maintenance-free ball bearings

Axial fan

With blades with an optimized aerodynamic profile (HyBlade® technology), statically balanced, inserted in a housing that enhances aeraulic performance and minimizes noise.

Microprocessor controller (accessory)

The advanced microprocessor control unit adjusts the fan speed of the brushless motor between 0 and 100%, so that in all partial load conditions the indoor unit will operate at a reduced speed with considerably reduced noise emissions and power consumption.

Cabinet

Pre-painted steel sheet cabinet complete with ABS corner trims, adjustable aluminium louvers (spring-operated) placed on the air outlet which enable an optimal distribution of air within the room to be heated.

Heat exchanger

High conductivity heat exchanger made with copper piping and aluminium fins assuring higher heat exchange than standard iron piping exchangers.

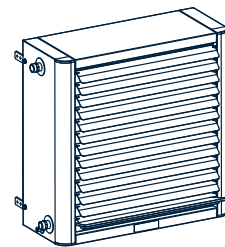
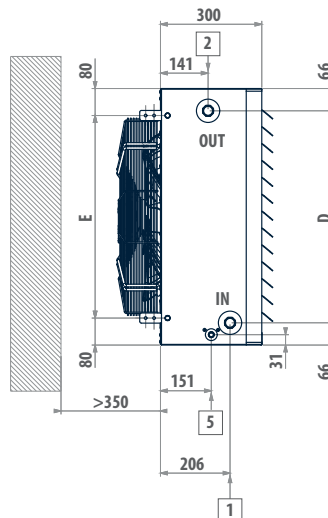
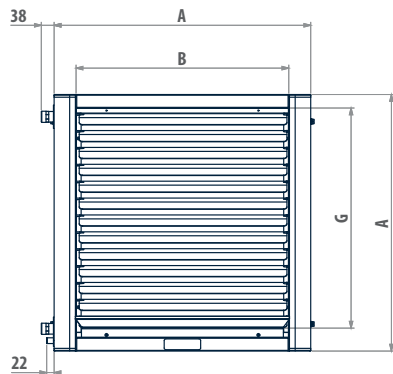
DIMENSIONAL DRAWINGS
AREO i

LEGEND

- 1** Water inlet connection, male gas
- 2** Water outlet connection, male gas
- 3** Condensate discharge Ø 17 mm

AREO i	A	B	D	E	G	1	2	kg
	mm	mm	mm	mm	mm	"	"	
12 - 13 - 14	460	330	300	380	380	3/4	3/4	19-19-20
22 - 23 - 24	560	430	400	480	480	3/4	3/4	25-26-27
32 - 33 - 34	660	530	500	580	580	1	1	33-34-36
42 - 43 - 44	760	630	600	680	680	1	1	39-41-42
52 - 53 - 54	860	730	700	780	780	1 1/4	1 1/4	50-53-54
62 - 63 - 64	960	830	800	880	880	1 1/4	1 1/4	58-61-63

Fan Heaters AREO i

RATED TECHNICAL DATA - HEATING MODE

AREO i			12	13	14	22	23	24	32	33	34
Power supply		V-ph-Hz	230-1-50								
Air flow rate max heating		m ³ /h	1626	1375	1250	2700	2350	2300	3100	2850	2770
Heating capacity	(1)	kW	11,2	14,0	16,0	18,7	23,9	26,8	28,7	31,5	35,4
Water flow	(1)	l/h	988	1232	1416	1651	2111	2368	2535	2778	3129
Water pressure drop	(1)	kPa	37	27	21	21	26	17	13	12	19
Sound power level	(2)	dB(A)	68	69	70	71	69	69	64	64	64
Power input	(3)	W	80	79	81	139	132	146	105	108	108

AREO i			42	42	43	43	44	44	52	52	53
Power supply		V-ph-Hz	230-1-50	400-3-50	230-1-50	400-3-50	230-1-50	400-3-50	230-1-50	400-3-50	230-1-50
Air flow rate max heating		m ³ /h	5800	8200	5400	7800	5350	7749	8800	9500	8450
Heating capacity	(1)	kW	48,5	59,0	53,9	67,0	61,0	76,6	58,2	60,7	73,2
Water flow	(1)	l/h	4279	5210	4756	5913	5386	6763	5138	5358	6457
Water pressure drop	(1)	kPa	31	44	30	44	20	30	24	25	27
Sound power level	(2)	dB(A)	71	81	72	81	72	82	80	80	82
Power input	(3)	W	318	844	334	840	344	850	715	859	766

AREO i			53	54	54	62	62	63	63	64	64
Power supply		V-ph-Hz	400-3-50	230-1-50	400-3-50	230-1-50	400-3-50	230-1-50	400-3-50	230-1-50	400-3-50
Air flow rate max heating		m ³ /h	9150	8100	8850	7200	11200	6700	10500	6200	9750
Heating capacity	(1)	kW	76,6	80,6	85,0	77,0	100	88,2	118	87,8	118
Water flow	(1)	l/h	6764	7114	7503	6797	8861	7789	10393	7751	10446
Water pressure drop	(1)	kPa	29	29	32	18	28	24	39	23	39
Sound power level	(2)	dB(A)	80	82	81	69	78	70	79	71	79
Power input	(3)	W	876	776	875	248	845	259	864	266	875

- (1) Water temperature 85°C / 75°C, air temperature 15°C - 100% of the max speed
 (2) Sound power measured according to standards ISO 3741 - 100% of the max speed
 (3) Measured at 100% of the max speed

RATED TECHNICAL DATA - COOLING MODE

AREO i		12	13	14	22	23	24	32	33	34
Power supply	V-ph-Hz	230-1-50								
Air flow rate max cooling	m ³ /h	865	936	899	1538	1616	1570	2409	2362	2412
Heating capacity	(1) kW	7,81	11,0	12,9	13,6	19,0	21,0	24,7	28,0	32,4
Water flow	(1) l/h	689	971	1136	1199	1673	1850	2179	2469	2856
Water pressure drop	(1) kPa	20	18	14	12	17	11	10	10	16
Total cooling capacity	(2) kW	2,25	3,17	3,71	3,49	5,50	5,80	5,59	7,06	9,78
Sensible cooling capacity	(2) kW	1,77	2,48	2,89	2,96	4,29	4,63	5,12	5,99	7,42
Water flow	(2) l/h	385	544	637	599	944	996	959	1213	1679
Water pressure drop	(2) kPa	10	9	7	5	9	5	3	4	9
Sound power level	(3) dB(A)	47	54	55	57	59	64	58	59	60
Power input	(4) W	36	44	45	25	46	63	47	57	68

AREO i		42	42	43	43	44	44	52	52	53
Power supply	V-ph-Hz	230-1-50	400-3-50	230-1-50	400-3-50	230-1-50	400-3-50	230-1-50	400-3-50	230-1-50
Air flow rate max cooling	m ³ /h	3346	3399	3492	3278	3421	3282	4644	4536	4492
Heating capacity	(1) kW	35,0	35,3	41,2	39,5	45,7	44,5	40,5	40,0	50,0
Water flow	(1) l/h	3087	3115	3631	3489	4038	3927	3578	3529	4417
Water pressure drop	(1) kPa	18	18	19	18	12	11	12	12	14
Total cooling capacity	(2) kW	9,66	9,77	12,3	11,8	13,1	12,7	10,6	10,4	14,4
Sensible cooling capacity	(2) kW	7,80	7,88	9,43	9,03	10,2	9,93	8,89	8,74	11,3
Water flow	(2) l/h	1658	1675	2109	2020	2240	2172	1825	1790	2462
Water pressure drop	(2) kPa	8	8	10	9	6	6	5	5	7
Sound power level	(3) dB(A)	61	64	63	64	63	63	64	63	64
Power input	(4) W	91	69	118	73	120	76	97	92	105

AREO i		53	54	54	62	62	63	63	64	64
Power supply	V-ph-Hz	400-3-50	230-1-50	400-3-50	230-1-50	400-3-50	230-1-50	400-3-50	230-1-50	400-3-50
Air flow rate max cooling	m ³ /h	4365	4706	4653	6011	5888	6005	5605	5861	5779
Heating capacity	(1) kW	49,1	57,5	57,1	68,8	67,9	82,1	78,3	84,5	83,7
Water flow	(1) l/h	4338	5076	5040	6075	5996	7241	6912	7458	7387
Water pressure drop	(1) kPa	13	16	16	14	14	21	19	22	21
Total cooling capacity	(2) kW	14,1	17,6	17,5	17,3	17,0	24,5	23,3	26,7	26,5
Sensible cooling capacity	(2) kW	11,1	13,3	13,2	14,8	14,6	18,8	17,9	19,8	19,6
Water flow	(2) l/h	2415	3025	2999	2963	2922	4212	3999	4586	4542
Water pressure drop	(2) kPa	7	9	9	6	6	11	10	13	12
Sound power level	(3) dB(A)	64	66	66	64	62	67	62	70	65
Power input	(4) W	96	141	134	157	150	195	152	232	205

(1) Water temperature 85°C / 75°C, air temperature 15°C - max speed available in cooling mode

(2) Water temperature 7°C / 12°C, air temperature dry bulb 27°C, wet bulb 19°C (47% relative humidity) - max speed available in cooling mode

(3) Sound power measured according to standards ISO 3741 - max speed available in cooling mode

(4) Measured at max speed available in cooling mode

All data reported in the table above refer to maximum allowed ventilation speed in order to avoid the drag of the condensation drops generated in the heat exchanger.

Air destratifiers

DST 1700 - 9100 m³/h



Horizontal installation



Axial fan

PLUS

- » Simple installation
- » Overload cut-out and safety thermostat are standard
- » Adjustable louvers
- » HyBlade® axial fans

The solution for eliminating hot air stratification in industrial environments

In industrial environments characterized by high ceilings and heating with hot air systems, the need to maintain a comfortable temperature at the floor level for the personnel results in the inconvenience of concentrating high-temperature air in the upper part of the area. Therefore, the heat remains trapped and unused near the roof and it is destined to be lost outdoors, thus increasing the building's heat loss.

The DST series air destratifiers eliminate this problem, generating a descending vertical air flow that is able to reduce the difference in temperature of the air between the floor and the ceiling up to a maximum of approximately 3 °C. During the summer months the DST air destratifiers can be used to achieve effective ventilation. They are equipped with a fan drive unit consisting of axial fans and asynchronous, single-phase, and three-phase electric motors depending on the size, with external rotor, which guarantees compatibility with the most recent regulations on limiting energy consumption.

The safety thermostat and the magnetothermic motor protection device with manual reset, installed in the unit as standard equipment, together with the convenient mounting brackets and baffles that can be adjusted to direct the air flow, make installation particularly easy without the use of further accessories.



MAIN COMPONENTS
Fan drive assembly

The axial fan, with Hyblade® type airfoil blades made of aluminum and coated with plastic material, possesses the unique characteristics of both materials: sturdiness and quietness are combined with a highly efficient asynchronous electric motor with external rotor.

Fan stop thermostat

It is installed on the unit and allows the temperature to be set at which destratifier operation is activated.

Structure

Pre-painted sheet steel structural work equipped with ABS and adjustable aluminum baffles.

RATED TECHNICAL DATA

DST			14	26	36	46	56	66
Fan speed		rpm	1400	900	900	900	900	750
Rated air flow		m ³ /h	1710	3083	4199	7220	8142	9139
Minimum installation height		m	3,00	3,50	4,50	5,00	7,00	6,50
Maximum installation height		m	5,00	5,50	7,00	7,50	9,00	10,0
Power supply		V-ph-Hz	230 - 1 - 50	230 - 1 - 50	400 - 3 - 50	400 - 3 - 50	400 - 3 - 50	400 - 3 - 50
Power input		W	62	110	160	390	418	320
Absorbed current		A	0,30	0,50	0,30	0,70	0,70	0,60
Sound power level	(1)	dB(A)	65	68	72	76	78	70

(1) Sound power measured according to standards ISO 3741

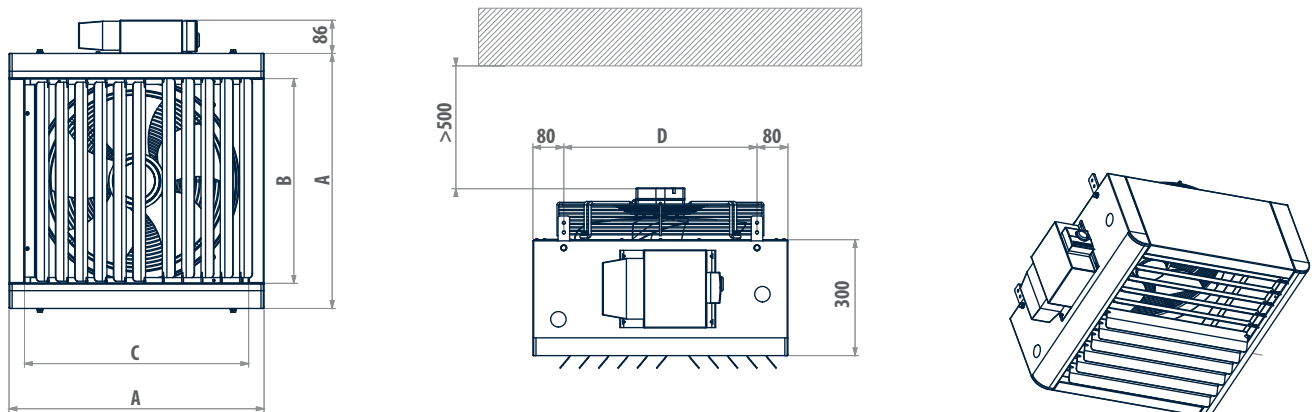
DIMENSIONAL DRAWINGS
DST

DST	A	B	C	D	E
	mm	mm	mm	mm	mm
14	460	300	350	300	500
26	560	400	450	400	500
36	660	500	550	500	525
46	760	600	650	600	515
56	860	700	750	700	535
66	960	800	850	800	535



CONTROLLERS AND SOFTWARE FOR HYDRONIC INDOOR UNITS

Introduction	p.140
TED	p.144
LED503	p.145
MYCOMFORT	p.146
EVO	p.148
ERGO LIGHT	p.150
ERGO	p.152



Galletti controls



Air-conditioning control is now quick and easy: effective room comfort is efficiently, simply, and intuitively accessible with Galletti control panels, from the simplest electromechanical control for setting the fan speed to microprocessor controls for complete temperature and humidity control.

Both ON/OFF and modulating 2- and 3-way valves are managed according to the temperature and humidity values measured.

The integrated management of the controls is completed with ERGO, supervision software that allows the creation of sophisticated adjustment logics whose goals are to meet the required level of comfort and to achieve energy savings.

Controls that can be integrated into any type of system



The wide range of Galletti controllers offers a multitude of installation options.

No fewer than 7 controls designed for on-board installation guarantee simple and elegant solutions. Specific installation kits allow mounting in the ESTRO, FLAT, 2x1 hydronic indoor units. This gives users control of the temperature at their fingertips and a solution that can be integrated in any type of environment.

There is now an even wider range of wall-mounted controllers: 9 controls with the option to manage, from a single point, more than one indoor unit in the same room.

In addition to these, an infrared remote control is also available for high wall-mounted indoor units and cassette fan coil units.

Controls of every level for any need



Galletti's offering is suitable for every need of cost-effectiveness and functionality. With its 9 electromechanical controls and its 5 microprocessor controls, Galletti is a market leader due to the diversity of its range of products. The devices offered in its catalogue are capable of interacting with multiple-speed indoor units or with modulating ventilation managing various different dynamics of thermostatisation and any serial communication.

Serial Communication: different possibilities for different needs

Galletti offer of RS485 serial port microprocessor controls, allows a suitable single terminal management, literally opening the doors to every plant adjustment need. The circulation of information on a bus-type network via Modbus communication protocol, standard in the HVAC field, is completed and combined with Power Line Communication (PLC), enabling a customised and easier interaction between user and plant.

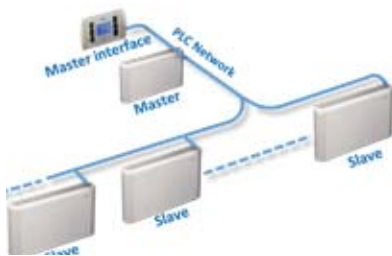
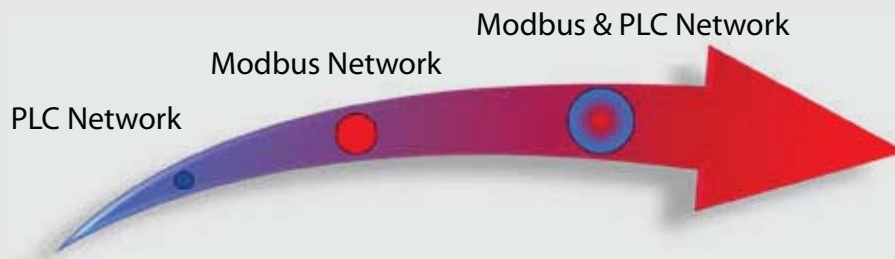

Power Line Communication (PLC) Network

» **Easy installation**

- » Single interface to control multiple units
- » Electrical wires reduction
- » Slave units repeat exactly Master unit instructions
- » Suitable solution for terminal units submitted to the same thermal charge
- » Available with EVO controller

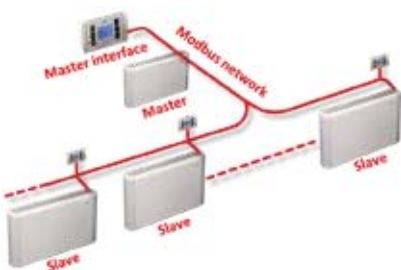

Modbus Network

» **Suitable solution for terminal units submitted to different charges**

- » Each unit is equipped with its own sensors
- » Master unit sets the main parameters
- » Multiple degrees of freedom settable for Slave units
- » Available with MYCOMFORT or EVO controllers



Mixed Network

» **Ideal solution for hotels or places with multiple zones to be conditioned**











- » Key areas controlled via Modbus protocol and replica of the same instructions via Power Line Communication (PLC)
- » Master unit can be a simple controller or a more complex supervision system
- » Monitoring with decreasing degree of autonomy
- » Contemporary use of Modbus Network and Power Line Communication (PLC) with both advantages
- » Available with EVO controller

Controllers and software for indoor hydronic units

Overview page of controls for hydronic indoor units

The following table can be used to quickly identify the most suitable control panel according to the functionality required.

ELECTROMECHANICAL CONTROLLERS

		CB	CD	CDE	TB	TD	TIB	TDC	TD4T	TA	TA2
											
Installation	On-board	✓	–	–	✓	–	✓	–	–	–	–
	Wall	–	✓	✓	–	✓	–	✓	✓	✓	✓
System	2 pipes	✓	✓	–	✓	✓	✓	✓	✓	✓	✓
	4 pipes	–	–	–	–	–	–	–	✓	–	–
Adjustment	Air thermostat	–	–	–	✓	✓	✓	✓	✓	✓	✓
	3 speeds	✓	✓	✓	✓	✓	✓	✓	✓	–	–
	4 speeds	–	–	–	–	–	–	–	–	–	–
	Automatic speeds	–	–	–	–	–	–	–	–	–	–
	Variable speed	–	–	–	–	–	–	–	–	–	–
	Dehumidification / RH reading	–	–	–	–	–	–	–	–	–	–
External sensors	Water sensor	–	–	–	–	–	–	–	–	–	–
	Remote air sensor	–	–	–	–	–	–	–	–	–	–
	Remote RH sensor	–	–	–	–	–	–	–	–	–	–
	Water operating thermostat	✓	✓	✓	✓*	✓	✓*	✓	–	✓	–
External devices management	ON/OFF valve management	–	–	–	✓*	–	✓*	–	✓	✓	✓
	Modulating valve management	–	–	–	–	–	–	–	–	–	–
	Control of heating element	–	–	–	–	–	–	–	–	–	–
	Digital outputs	–	–	–	–	–	–	–	–	–	–
Ancillary functions	Summer/Winter local	–	–	–	–	✓	✓	–	✓	–	✓
	Summer/Winter water	–	–	–	–	–	–	–	–	–	–
	Summer/Winter air (4 pipes)	–	–	–	–	–	–	–	–	–	–
	Economy	–	–	–	–	–	–	–	–	–	–
	Digital inputs	–	–	–	–	–	–	–	–	–	–
	Modbus communication	–	–	–	–	–	–	–	–	–	–

✓* options that are not mutually compatible



Overview page of controls for hydronic indoor units

The following table can be used to quickly identify the most suitable control panel according to the functionality required.

MICROPROCESSOR CONTROLLERS

MICROPROCESSOR CONTROLLERS WITH DISPLAY

TED2T	TED4T	TED10	MYCOMFORT BASE	MYCOMFORT MEDIUM	MYCOMFORT LARGE	EVO	LED503		
✓	✓	✓	✓	✓	✓	—	✓	On-board	Installation
✓	✓	✓	✓	✓	✓	✓	✓	Wall	
✓	—	✓	✓	✓	✓	✓	✓	2 pipes	System
—	✓	✓	✓	✓	✓	✓	✓*	4 pipes	
✓	✓	✓	✓	✓	✓	✓	✓	Air thermostat	Adjustment
✓	✓	✓	✓	✓	✓	✓	✓	3 speeds	
—	—	—	✓	✓	✓	✓	✓*	4 speeds	
—	—	✓	✓	✓	✓	✓	✓	Automatic speeds	
—	—	✓	—	—	✓	✓	—	Variable speed	
—	—	—	—	✓	✓	✓	—	Dehumidification / RH reading	
✓	✓	✓	✓	✓	✓	✓	✓	Water sensor	External sensors
✓	✓	✓	✓	✓	✓	✓	✓	Remote air sensor	
—	—	—	—	✓	✓	✓	—	Remote RH sensor	
—	—	—	—	—	—	—	—	Water operating thermostat	
✓	✓	✓	✓	✓	✓	✓	✓	ON/OFF valve management	External devices management
—	—	—	—	—	✓	✓	—	Modulating valve management	
—	—	—	✓	✓	✓	✓	✓*	Control of heating element	
—	—	—	—	—	✓	✓	—	Digital outputs	
✓	✓	✓	✓	✓	✓	✓	✓	Summer/Winter local	Ancillary functions
—	—	—	✓	✓	✓	✓	✓	Summer/Winter water	
—	✓	✓	✓	✓	✓	✓	✓	Summer/Winter air (4 pipes)	
—	—	—	✓	✓	✓	✓	—	Economy	
—	—	—	✓	✓	✓	✓	✓	Digital inputs	
—	—	—	—	✓	✓	✓	—	Modbus communication	

✓* options that are not mutually compatible

Simplified electronic controller

TED

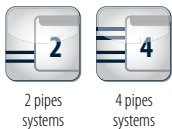

A series of three easy and efficient controllers

The three versions of the new electronic device TED, are Galletti answer to the demand of a simple and flexible controller suitable to the different plant needs.

The assignment of the operating conditions is intuitive and easy-applicable, and the supplied accessories allow the installation on board in addition to the classical on wall.

The controller is moreover equipped in all versions with dedicated contacts for both air and water probes. In this latter case it is therefore possible to consent ventilation only if water temperature is adequate to the normal operating condition.

PLUS

- » Three versions depending on plant and terminal units
- » Easy application
- » Wall mounted or on-board installation
- » Units supplied with BLDC electric motor supported (only 0-10 V version)



AVAILABLE VERSIONS



TED2T

- It supports terminal units equipped with asynchronous electric motor in 2 pipes plants
- ON/OFF valve supported
- Water consent on the basis of temperature



TED4T

- It supports terminal units equipped with asynchronous electric motor in 4 pipes plants
- Two ON/OFF valves supported
- Seasonal manual or automatic switch (on the basis of air temperature)
- Water consent on the basis of temperature



TED10

- It supports terminal units equipped with BLDC electric motor thanks to its internal 0-10 V signal generator
- Suitable for both 2 or 4 pipes plants
- Manual or automatic speed adjustment mode
- Water consent on the basis of temperature

ACCESSORIES

Electronic microprocessor control panels

- KB A** On-board ESTRO FA installation kit suitable for TED controller
- KB F** On-board FLAT/FLAT S installation kit suitable for TED controller

- KB L DX** On-board ESTRO FL/FU/FB installation kit on the right side suitable for TED controller
- KB L SX** On-board ESTRO FL/FU/FB installation kit on the left side suitable for TED controller
- TED SWA** Water temperature sensor for TED controls

Recess wall-mounted control panel

LED503



PLUS

- » Complete management of indoor units for 2- or 4-pipe systems
- » Intuitive use
- » Large LED display for ease of visualization
- » Can be installed in a 503 socket box

Simplicity and elegance for the management of water system indoor units

The proposed microprocessor control panels for Galletti indoor units is completed by the LED503 command with LED display that is designed for recess wall mounting or mounting on the ESTRO series fan coils. LED503 includes an advanced software program developed internally by Galletti's R&D department focusing on ease of use and simplicity of installation and programming.

LED503 makes it possible to control up to 4 fan speeds, automatically or manually, together with the management of 2- or 3-way valves in 2- or 4-pipe air conditioning systems.

Due to the presence of a configurable digital input it can easily be remotely interfaced to centralize specific functions such as seasonal switchover of the operating mode, activation of the economy mode, or simply turning it on or off.

The proportional adjustment algorithm automatically adjusts the fan speed depending on the value of the difference between the ambient temperature and the set setpoint and allows precise adjustment of the room conditions.

The water sensor, which can be installed as an accessory, is used to verify that the temperature of the heat transfer fluid is always at an optimal level and compatible with the active operating mode.

The seasonal switchover can be made automatic depending on the air or water temperature, making this controller the perfect tool for applications in both the residential sector and the commercial or hotel sector.

LED503 can be easily integrated in the room to be air conditioned due to the option to choose between three different frames.

Alternatively it is also possible to use commercial plates of the Idea and Rondò series in the Vimar catalogue.



RAL7031 grey plate



RAL9003 white plate



RAL9005 black plate



LED503 on-board controller installation kit for ESTRO

ACCESSORIES

Electromechanical control panels		COW	Finishing plate for LED 503 controller, RAL9003 white
IPM	Circuit board for connection of UTN 30-30A-40-40A to control panels.	KL	LED503 on-board controller installation kit for ESTRO
Electronic microprocessor control panels with display		Power interface and regulating louver controllers	
COB	Finishing plate for LED 503 controller, RAL9005 black	KP	Power interface for connecting in parallel up to 4 fun coil units to the one controller
COG	Finishing plate for LED 503 controller, RAL7031 grey		

Electronic microprocessor controller with LCD display

MYCOMFORT



Three different proposals for a customized level of comfort

Climate control becomes fast and simple: interior comfort conditions can be controlled thanks to the new MYCOMFORT control panels, the connection node of Galletti integrated systems.

The microprocessor control panel allows you to set the operating mode of the indoor hydronic units in such a way as to achieve conditions of interior comfort and complete control over the air conditioning system.

The controller features a large-sized liquid crystal display with incorporated keypad for setting and reading environmental parameters and the operating parameters of the indoor unit connected to it.

There is a vast choice of accessories available, which allow either wall mounting or installation on board the indoor unit.



Supervision
ERGO



BUS com-
munication



Management
of external
devices

PLUS

- » Three versions depending on the customer's requirements
- » Large display
- » User-friendly interface
- » Wall mounted or on-board installation
- » Easy connection and startup



AVAILABLE VERSIONS

BASE

Temperature-based control of fan coil (4 fan speeds) unit and regulating valves.

MEDIUM

Control of fan coil unit (4 fan speeds) and valves based on temperature and humidity, connection to ERGO systems, setting up of small networks in slave mode.

LARGE

Control of fan coil unit (4 fan speeds) and regulating valves based on temperature, humidity, weekly timer, connection to ERGO systems, setting up of small networks in master mode, backlit display, control of modulating devices (valves, BLDC motors).

MAIN COMPONENTS AND FEATURES

Shell

The outer shell is made of ABS that has been UV treated to retain the original colour over time. Its pleasant design makes it suitable for high-grade installations in sophisticated environments.



Display

3" are available to the user to clearly view all the data of interest for efficient adjustment. The use of intuitive pictograms to represent all the functions makes it highly user friendly.



Terminal board

MYCOMFORT features quick-connect terminals which enable hassle-free wiring. Programming of the functions and address is simplified as it can be done directly from the keypad and display.



Control and savings

Automatic control of the unit's cooling and heating functions according to air and water temperatures.

Real comfort

MYCOMFORT can control and maintain comfort in terms of both temperature and humidity thanks to the presence of a sensor which measures ambient humidity and enables dehumidification cycles to be carried out by acting on valves, ventilation and the water set-point.

Management of accessories and external devices

This controller allows the management of both ON/OFF and modulating 2- and 3-way valves, and in addition it is possible to manage external devices such as chillers, boilers, and zone valves. It is performed by means of no-voltage ON/OFF contacts, depending on the environmental parameters.

Supervision

This controller can be integrated with the ERGO software monitoring system, by means of the RS485 bus connection, from which it is possible to display all the functions and access to the MYCOMFORT programming menu.

MYCOMFORT FEATURE

	Base	Medium	Large
4-speed fan control	•	•	•
ON/OFF valve control	•	•	•
ON/OFF via external enable signals / digital inputs	•	•	•
External devices/digital outputs ON/OFF			•
Air temperature sensor	•	•	•
Water temperature sensor	•	•	•
Humidity air probe		•	•
BUS/RS485 connection		•	•
Modulating valves/0-10V outputs control		•	•
Inverter fans/0-10V outputs control			•
Weekly clock			•
Backlit display			•

ACCESSORIES

Electronic microprocessor control panels with display

DIST	MY COMFORT controller spacer for wall mounting
KB2X1E	MY COMFORT on-board installation KIT for 2X1
KBESTE	MY COMFORT on-board installation kit for ESTRO

KBFLAE	MY COMFORT on-board installation KIT for FLAT
MCSUE	Humidity sensor for MY COMFORT (medium e large), EVO
MCSWE	Water sensor for MYCOMFORT, EVO, LED 503 controllers

Electronic microprocessor controller with remote user interface

EVO

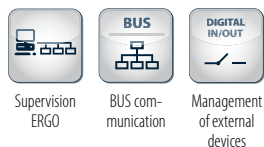

Intuitive and user-friendly multi-purpose regulator

EVO encompasses the best of Galletti adjustment with regard to hydronic indoor units.

The EVO software, which was developed entirely by Galletti's Technical Department, consists of two distinct parts in two microprocessors. The first of these, resident on the power board, manages the monitoring of the parameters and the adjustment logics. The second part of the software, which is loaded on the user interface microprocessor, guarantees true communication, by means of which the installer and the user are guided in the configuration and use of the controller.

If on-board installation of the power board is requested, which is an option that is available for the majority of Galletti hydronic indoor units, during the wiring phase you just need to connect the user interface using a two-core shielded cable. This extraordinary simplicity cuts installation time and costs in half.

The EVO controller has been designed to govern the operation of Galletti indoor units with single-phase multi-speed asynchronous motor or modulating speed BLDC motors. Specifically, its advanced technology makes it possible to establish control networks that are suited to meet any need, for automatic and intelligent management of the system's indoor units.

PLUS

- » Considerable savings in the installation phase
- » User-friendly interface
- » RS485 and OC serial communication
- » Advanced de-humidifying function
- » Simultaneous control of 3 modulating devices
- » Advanced control of time schedules



ACCESSORIES

Electromechanical control panels

IPM Circuit board for connection of UTN 30-30A-40-40A to control panels.

Electronic microprocessor control panels with display

MCSUE Humidity sensor for MY COMFORT (medium e large), EVO

MCSWE Water sensor for MYCOMFORT, EVO, LED 503 controllers

FUNCTIONS

Automatic control of time slots

The user interface makes it possible to set the ON/OFF status of the control and the desired setpoint, on an hourly basis, for the different days of the week. If the above-mentioned operating parameters are set on a master unit, they can be replicated on all the connected slaves.



Modulating devices control

EVO is capable of simultaneously controlling up to two modulating valves and one BLDC fan, making it possible to vary the air flow rate and the water flow rate in the heat exchanger, adapting to the thermal load.

Humidity control

EVO offers the possibility of automatically activating a dehumidification process depending on the relative humidity and a settable setpoint. This function requires a humidity sensor that is available as an accessory.

Serial communication

The controller has serial ports for RS485 communication and power-line communication that allow the development of control networks that are adequate for every need.

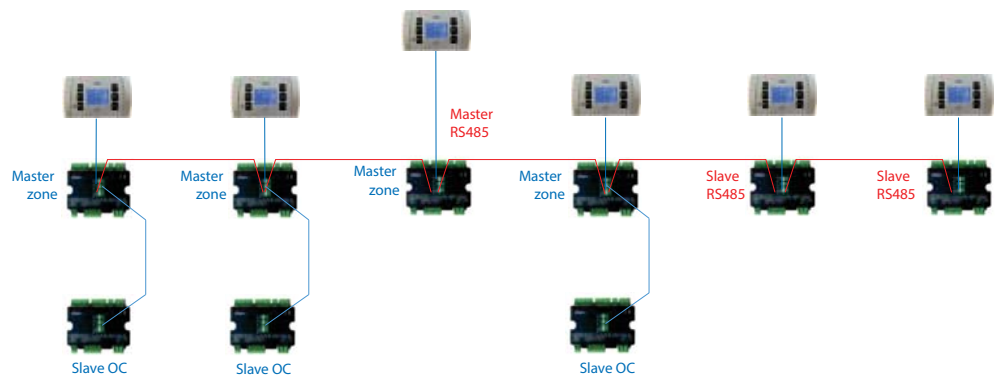

CONNECTIVITY

By combining digital outputs and inputs present on EVO, it is possible to develop synergetic solutions with other system components.

Remote activation of heat recovery units

The heat recovery units are essential for maintaining good ventilation in the rooms, especially during periods with high occupancy. With EVO it is possible to set a series of weekly time slots that take into account the effective occupancy of the rooms. The activation of indoor units in those zones will be managed concurrently with the activation of the heat recovery units. This makes it possible to combine good air quality, temperature and humidity comfort, and considerable energy savings by deactivating all the systems when they are not necessary.



“Economy”

A typical need in hotel rooms and in other rooms with variable occupancy is the management of air conditioning with reduced operation when the user is not present. This solution, which is often accomplished by means of occupancy sensors or magnetic readers, guarantees considerable energy savings, but requires the possibility to force the fan coil unit to operate in Economy mode in a simple and effective manner. This is all possible with EVO, which has 3 pre-configured digital inputs for ON/OFF, Economy mode, and remote summer/winter switchover.

Activation of external dehumidifier/humidifier

This control implements the humidity control function in relation to a settable setpoint. By connecting the appropriate sensor to the control it is possible to not only vary the fan coil unit's adjustment dynamics, but also manage the calls to external devices such as humidifiers and dehumidifiers.

Simplified monitoring system with touch screen display

ERGO LIGHT



Centralized control for indoor units and heat pumps

ERGO LIGHT takes advantage of a modern and attractive interface as a base for easy, integrated, and effective indoor units/system monitoring.

The product development philosophy has been designed to provide ease of configuration and use in maintaining the typical features of a monitoring system. The hardware, comprised of a touch screen display, leverages new technologies to make the installation suitable for all environments.

The software, which is already integrated into the product, allows immediate consultation of the information regarding the operation of each controlled unit, allowing rapid correction and exploiting the logics implemented to maximize energy savings.



BUS communication



Management by zones



Touch screen device

PLUS

- » Display touch screen 7"
- » 10 points controlled
- » Indoor unit-generation system integrated control
- » Management of heat pumps and multi-purpose units
- » Can be integrated with all EVO-controlled indoor units
- » Integrated software and hardware
- » Easy installation
- » Ready to use
- » Dimensions: 187 x 147 x 85 mm



ACCESSORIES

Electronic microprocessor control panels with display

EVOBOARD Circuit board for EVO control

EVODISP

User interface with display for EVO controller

MCSWE

Water sensor for MYCOMFORT, EVO, LED 503 controllers

MAIN FUNCTIONS

Individual unit management

The monitoring system can be adapted to any type of indoor unit, whether it is equipped with an ON/OFF motor or a BLDC motor.

An easily understood user interface allows all the operating parameters of each monitored zone to be displayed and edited. Therefore, all features can be managed remotely through simple and intuitive dedicated screens.



Generation system control

The system is not limited to controlling only hydronic indoor units, but is also suitable for managing any heat pump connected with the system, making changes to the main parameters immediately. Furthermore, the multi-purpose units are supported, thus guaranteeing control of the temperature of the DHW produced. An intuitive screen guarantees the modification of the summer and winter set-points and the main operating conditions of the unit.



Simple configuration

Each easily accessible screen has been designed with the aim of facilitating interaction with the user. For example, you can configure the system with a few clicks, selecting the number of fan coils controlled and the possible presence of a heat pump. A convenient summary screen allows you to send power on and power off signals to all connected hydronic units and to a possible heat pump, keeping the settings that were previously set.



CONNECTIVITY

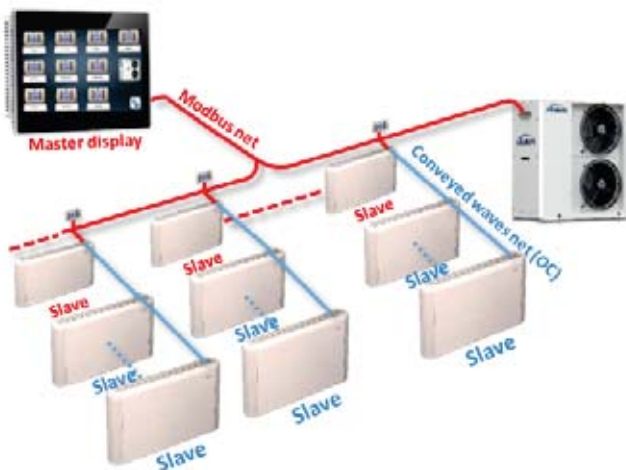

Zone control with Modbus protocol

ERGO LIGHT is able to monitor and adjust the ambient conditions of 10 distinct zones.

The communication network is a bus in which information is exchanged via Modbus protocol. The number of indoor units can be expanded, because each Master can replicate the commands to other Slave units through power-line communication.

The heat pump is connected to the network via the RS485 serial card integrated with the unit's microprocessor. Fan coil side the monitoring system is supported by the microprocessor control of EVO Galletti, equipped with RS485 communication port. Therefore, you can take advantage of all the EVO features, such as the minimum room temperature control, the economy savings function, and the ability to enable previously selected time periods on individual hydronic units.

Supervision software for air conditioning systems

ERGO



BUS communication



Management of external devices



Time schedules



Management by zones

Complete and automatic control of the air conditioning system

Efficiency and comfort require a careful check of every single part of the system, enhancing its capacities and managing it according to the user's needs.

It is now no longer necessary to worry about comfort and energy savings: ERGO takes care of everything.

ERGO can be installed on any control panel with Windows operating system and interfaces with Galletti hydronic indoor units and heat pumps, with generation system operators like EVO SYSTEM, and with external devices, circulators, and valves.

The ERGO solution, a result of Galletti's long-time experience in HVAC technologies, was created in response to the need to control heating and air conditioning systems in a simple manner with a view to saving energy.

ERGO is intended specifically for hotels, administrative centers, offices, and apartment buildings and offers a control strategy that adapts the chiller and indoor units' operation to the actual thermal load requirements, guaranteeing:

- energy savings in the production of chilled water
- simple, economical installation
- a reduction in operating costs
- user-friendly operation
- advanced system monitoring capabilities
- centralised control over the system

PLUS

- » Automatic correction of operating parameters
- » Time schedules
- » Zone Management
- » Selection of the degree of autonomy offered to the individual user
- » Management of external devices
- » Available On-line Web Server version



ACCESSORIES

Electronic microprocessor control panels with display

EVOBOARD	Circuit board for EVO control
EVODISP	User interface with display for EVO controller
MCLE	Microprocessor control with display MY COMFORT LARGE
MCME	MYCOMFORT MEDIUM electronic controller with display
MCSWE	Water sensor for MYCOMFORT, EVO, LED 503 controllers

Converters

EYIOEXP	Remote power interface
VM11000203	Converter USB-RS485
VM11000204	Converter TCP/IP - RS485
VM11000205	RS485 repeater

FUNCTIONS

Comfort index

The software analyses the operating conditions of indoor units on a real-time basis in order to determine the actual instantaneous thermal load of each user, an essential prerequisite for implementing an adjustment strategy that minimises operating costs while enabling the system to work in the best possible conditions.

Self-adaptive function

The adaptive function adjusts the heat pump's setpoint according to the effective power required in the various zones to be air conditioned. This guarantees a more accurate adjustment and an increase in the heat pump's efficiency, which can reach up to 20%.

Management of external devices

This software allows the automatic or manual management of external devices such as circulators, pumps and zone valves, and heat recovery units. Its activation and deactivation could be, for example, linked to seasonality or associated with the time slots of a specific zone.

Automatic adjustment

The individual zones' setpoint changes automatically on an hourly basis depending on the settings. In the configuration phase the heating requirements in the different seasons are evaluated, thereby achieving automatic and intelligent management without any additional actions by the user.

Time schedules management

The system turns on and off the indoor units in the various zones depending on actual need and the presence of people. This makes it possible to considerably reduce consumption and eliminate in the room the possibility of human error in managing the air conditioning.

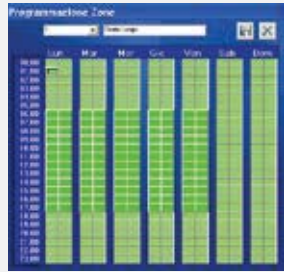

Operational data acquisition

ERGO allows the storage of large amounts of operational data collected by individual indoor units or averaged for the zones of interest. This provides an essential tool for system operators and maintenance providers that is able to highlight criticalities and possible optimization of the system.

Degree of autonomy

This monitor allows you to choose between 4 different levels of remote control, thereby defining, according to requirements, what modification options to offer the user.



CONNECTIVITY

The ERGO system places a large number of indoor units in communication with each other and offers the user the option of overall control from a single location with minimum effort.

ERGO operates by means of communication with Modbus protocol on RS485 network. The system is capable of managing up to 240 indoor units controlled by MY-COMFORT and EVO and supports "mixed" networks with both types of controllers. Within the system up to 3 heat pumps can be managed, linking their operation to that of the hydronic indoor units. Galletti offers modular solutions that are adequate for every need. The converters offered allow the RS485 BUS to be connected directly to the computer or to establish up to 8 communication branches from a single Ethernet backbone.

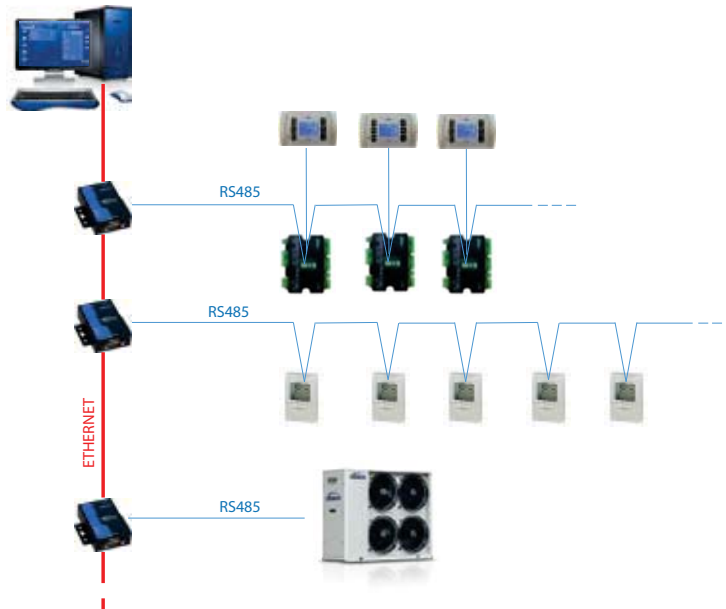



AIR CHILLERS AND HEAT PUMPS

Introduction	p. 156
MPI DC	p. 158
MCI	p. 162
MPE	p. 166
EvitechH	p. 176
VIPER	p. 184
SCX	p. 196
LCX	p. 210
BCX	p. 226
LSE	p. 232
MTE	p. 244
LER	p. 252



Air chillers and heat pumps

Range of capacities between 4 and 1200 kW to meet engineering and installation requirements.

8 different series of units, cooling only or heat pump, from which professionals can make the proper choice depending on their design and installation requirements.

The feature that all Galletti units have in common is the complete configurability of every model. The hydronic and aeraulic “plug & play” feature that allows immediate system application, the partial heat recovery from overheating for the production of hot water at the same time as operation in cooling mode, and the sophisticated controls that allow interconnection with monitoring systems using the most common protocols, are a few of the possibilities for customizing the air/water heat pumps and chillers. With Galletti, special becomes standard.



All-in-one solutions.

All Galletti air heat pumps and chillers are completely configurable on the hydronic side. Inside every unit, from 4 to 1200 kW, depending on the series, it is possible to install hydronic kits without modifying their dimensions, with the option of choosing the water circulation pump:

- » single pump, standard head or uprated (high head).
- » dual pump solution (OR): standard or uprated pump, operating singly. The pumps operate in turns on a time/fault basis. In the case, the microprocessor controls the pumps in such a way as to equally divide the hours of operation, changing over the pumps in the event of a fault.
- » dual pump solution (AND): standard or uprated pump, operating simultaneously. Connected in parallel, they deliver water at the nominal flow rate when operating simultaneously.

AEROTHERMAL ENERGY

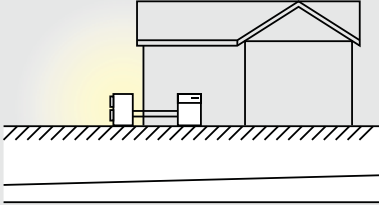

Air: a source that is always available

Galletti air/water units are characterized by a large operating range that allows them to adapt to use under any conditions. Cooling operation at full load with air temperatures up to 51 °C, which increases as a result of careful management of the step levels. During the winter period, production of water up to 60 °C and operation with external temperatures as low as -15 °C.



Finned block heat exchangers

They are generously sized and can use hose with a diameter of 8 mm, which reduces air side pressure drops, thereby considerably improving the unit's noise levels. The special engineering of the heat exchangers allows defrost cycles to be carried out at maximum speed in the models with heat pump operation, which brings clear benefits in terms of the integrated efficiency of the whole cycle. On request hydrophilic heat exchangers can be installed that partialize the water droplets and reduce obstruction by ice of the spaces between the fins, preventing the formation of frost at low temperatures. The finned block condensers can be fitted with a protective outer grille.



Air heat exchanger – micro-channel refrigerant coil

Micro-channel heat exchanger made of aluminium-manganese alloy fins, heads and channels made of long life alloy and copper coated user connections. Micro-channel technology together with an accurate thermodynamic project, ensure a reduced refrigerant charge up to 30 or 40% than the corresponding chillers equipped with usual condensing coils. This result appears to be extraordinary if related to the coherent choose of producing low TEWI units made by Galletti in order to reduce environmental impact in the HVAC sector.

Free-cooling

The Free-cooling units permit high energy saving when outdoor temperature is lower than the circulating fluid temperature (process industry, close control applications, information technology industry in general, congress halls, etc.). Free cooling exchanger performance depends on the difference between outdoor air temperature and circulating water temperature.

Outdoor packaged unit with BLDC compressor

MPI DC 10 - 29 kW



Large operating range and energy efficiency under every condition

The MPIDC series consists of 5 heat pump models and 5 cold only models and is intended mainly for residential or light commercial applications. Due to the control managed by a software program developed by Galletti, the MPIDC series' adjustment logic makes it possible to adjust the water delivery temperature to the set value and to control the compressor so that the power generated by the machine is adjusted to the thermal load required by the system. This represents a strategic feature in the limiting of energy consumption, because the effective thermal load of an air conditioning system is less than 60% of the nominal load most of the time.

The BLDC technology upon which is based the compressor's electric motor guarantees the ability to change the rotation speed in a frequency range between 30 and 120 Hz, thereby reducing at the same time the power consumption and thus maintaining a high level of efficiency in the operation at partial load and improved isentropic efficiency. These units' large operating range, which is also achieved due to the variable flow water circulator they are equipped with as a standard feature, guarantees operation with air temperatures from -15 °C up to 52 °C, while in heating mode it is possible to produce hot water up to 58 °C. This allows their use as a single generator in addition to summer air conditioning, even in medium-temperature heating systems and for the production of DHW. Furthermore, the innovative Smart Defrost System guarantees that defrosting always occurs in the most efficient manner even under the most extreme environmental conditions.

PLUS

- » Twin-rotary or scroll electronically-controlled compressor driven by an electric BLDC motor
- » Electronically controlled electronic expansion valve
- » Modulating hydraulic pump with stainless steel impeller
- » Incorporable inertial tank

MPIDC can be the only heat generator in low-power systems due to its large operating range that includes both low winter temperatures and high summer temperatures.

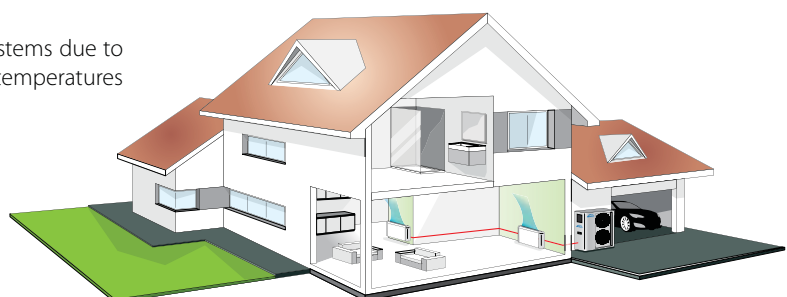

MAIN COMPONENTS

Structure

It is constructed of galvanized and painted sheet metal that is resistant to corrosive agents. Compressor compartment closed and accessible from three sides due to easily removable panels, available also with internal coating of sound-proofing material.

Compressor

Hermetic twin-rotary or scroll compressor driven by a permanent magnet BLDC motor and controlled by a trapezoidal wave inverter. It is attached to the base by means of rubber dampers to reduce the transmission of vibrations.

Heat exchanger

Finned coil made of copper pipes mechanically fixed to steel fins, accurately designed to minimize defrosting phase and optimize the efficiency of thermal exchange in every operating mode.

Electronically controlled electronic expansion valve

Key component for the proper functioning of the unit. The PID control algorithm allows it to quickly adapt to all operating conditions and to keep the cooling cycle stable.

Hydraulic kit

Variable flow centrifugal circulator with stainless steel impeller. An expansion vessel and the automatic filling tap are also included. An inertial buffer tank built into the structure is available as an optional accessory.

3-ways kit

This is a smart kit able to convert MPIDC heat pumps in multi-function units in order to fulfill every necessity of the hydraulic air-conditioning plant. It allows domestic hot water priority production thanks to Galletti thermal accumulators of the TP or TN series. It is composed of an electronic microprocessor with LCD display and a 3-ways motorised valve. It can also realize cycles to avoid genus Legionella proliferation thanks to an electric resistance



CONFIGURATOR

The models are completely configurable by selecting the version and the options. To the right is shown an example of configuration.

Version	Fields	1	2	3	4	5	6	7	8	9	10	11	12	13
MPIDC014HOAC		A	2	0	0	E	P	3	0	2	0	G	0	2

To verify the compatibility of the options, use the selection software or the price list.

AVAILABLE VERSIONS

Cooling only versions

MPIDC...CMAC Water chiller 230V - 1 - 50 Hz
MPIDC...COAC Water chiller 400V - 3N - 50 Hz

Versions with reversible heat pump

MPIDC...HMAC Air/water heat pump 230V - 1 - 50 Hz
MPIDC...HOAC Air/water heat pump 400V - 3N - 50 Hz

CONFIGURATION OPTIONS

- | | |
|--|--|
| 1 Expansion valve | M Refrigerant pressure gauges |
| A Electronic | 9 Remote control / Serial communication |
| 2 Water pump and accessories | 0 Absent |
| 1 LP pump + expansion vessel | 2 RS485 serial board (Carel / Modbus protocol) |
| 2 EC pump + expansion vessel | B BACNET IP / PCOWEB serial board (advanced controller required) |
| 3 Water buffer tank | F BACNET MS/TP / PCONET serial board (advanced controller required) |
| 0 Absent | G BACNET IP / PCOWEB serial board + supervision software Gweb (advanced controller required) |
| S Selected | S Remote simplified user panel |
| 4 Partial heat recovery | X Remote user panel for advanced controller |
| 0 Absent | 10 Special coils / Protective treatments |
| 5 Air flow modulation | 0 Standard |
| C Condensation control by phase-cut fans | B Pre-painted fins with epoxy painting |
| E Condensation control performed by EC fans | C Cataphoresis |
| 6 Antifreezing kit | I Hydrophilic |
| 0 Absent | R Copper-copper |
| E Plate exchanger | 11 Outdoor finned coil heat exchanger protection |
| P Plate exchanger and water pump | 0 Absent |
| S Plate exchanger, water pump and inertial tank | G Outdoor finned coil heat exchanger protection grille |
| 7 Acoustic insulation and attenuation | 12 Compressors options |
| 0 Absent | 0 Absent |
| 1 Compressor compartment acoustic insulation | 4 Outdoor coil trace heater |
| 2 Compressor sound blanket | 13 Onboard controller |
| 3 Compressor compartment acoustic insulation and sound blanket | 2 Advanced |
| 8 Refrigerant pipework accessories | |
| 0 Absent | |

ACCESSORIES

1701546	Remote simplified user panel
RYKAMF	Spring anti vibration shock mounts
RYMCL	MyChiller Plus (RS485 serial board required)

RYMCM	MyChiller Base (RS485 serial board required)
RYPAM	Rubber anti vibration shock mounts

WATER CHILLERS RATED TECHNICAL DATA

MPI DC C			010M	014	018	023	029
Power supply		V-ph-Hz	230 - 1 - 50	400 - 3N - 50	400 - 3N - 50	400 - 3N - 50	400 - 3N - 50
Cooling capacity	(1)(E)	kW	10,5	14,2	18,0	22,8	28,9
Total power input	(1)(E)	kW	3,42	4,89	7,82	7,91	12,5
EER	(1)(E)		3,07	2,90	2,30	2,88	2,31
SEER	(2)(E)		3,99	3,98	3,81	3,88	3,80
Water flow	(1)	l/h	1819	2455	3127	3935	4997
Water pressure drop	(1)(E)	kPa	23	30	47	27	42
Available pressure head - LP pumps	(1)	kPa	142	162	132	130	84
Cooling capacity	(5)(E)	kW	14,6	19,4	24,2	31,5	39,2
Total power input	(5)(E)	kW	3,61	5,27	8,59	8,49	13,6
EER	(5)(E)		4,04	3,68	2,82	3,71	2,88
Maximum current absorption		A	16	20	20	35	35
Compressors / circuits					1 / 1		
Expansion vessel volume		dm ³	5	5	5	5	5
Buffer tank volume		dm ³	30	30	30	50	50
Sound power level	(7)(E)	dB(A)	70	71	71	71	74
Transport weight unit with pump and tank		kg	184	218	218	262	262
Operating weight unit with pump and full tank		kg	201	235	235	299	299

HEAT PUMPS RATED TECHNICAL DATA

MPI DC H			010M	014	018	023	029
Power supply		V-ph-Hz	230 - 1 - 50	400 - 3N - 50	400 - 3N - 50	400 - 3N - 50	400 - 3N - 50
Cooling capacity	(1)(E)	kW	10,3	13,9	17,7	22,4	28,3
Total power input	(1)(E)	kW	3,42	4,89	7,81	7,90	12,5
EER	(1)(E)		3,03	2,84	2,27	2,84	2,26
SEER	(2)(E)		4,01	3,93	3,81	3,82	3,74
Water flow	(1)	l/h	1785	2407	3067	3861	4903
Water pressure drop	(1)(E)	kPa	22	29	44	26	40
Available pressure head - LP pumps	(1)	kPa	142	163	133	131	84
Heating capacity	(3)(E)	kW	11,6	15,8	21,8	24,8	34,0
Total power input	(3)(E)	kW	3,64	5,08	7,70	8,02	12,0
COP	(3)(E)		3,22	3,11	2,83	3,10	2,83
SCOP	(2)(E)		3,03	2,92	2,87	2,92	2,82
Heating energy efficiency class	(4)				A+		
Water flow	(3)	l/h	1986	2727	3752	4273	5853
Water pressure drop	(3)(E)	kPa	23	31	55	29	51
Available pressure head - LP pumps	(3)	kPa	137	155	109	116	45
Cooling capacity	(5)(E)	kW	14,3	19,1	23,8	30,7	38,5
Total power input	(5)(E)	kW	3,60	5,31	8,56	8,50	13,6
EER	(5)(E)		3,97	3,60	2,78	3,61	2,83
Heating capacity	(6)(E)	kW	12,1	16,5	22,6	25,6	34,7
Total power input	(6)(E)	kW	3,00	4,20	6,44	6,81	10,1
COP	(6)(E)		4,03	3,93	3,51	3,76	3,44
Maximum current absorption		A	16	20	20	35	35
Compressors / circuits					1 / 1		
Expansion vessel volume		dm ³	5	5	5	5	5
Buffer tank volume		dm ³	30	30	30	50	50
Sound power level	(7)(E)	dB(A)	70	71	71	71	74
Transport weight unit with pump and tank		kg	188	243	243	290	290
Operating weight unit with pump and full tank		kg	205	260	260	327	327

(1) Outdoor air temperature 35°C, water temperature 12°C / 7°C (EN14511:2013)

(2) η efficiency values for heating and cooling are respectively calculated by the following formulas: $[\eta = SCOP / 2,5 - F(1) - F(2)]$ e $[\eta = SEER / 2,5 - F(1) - F(2)]$. For further information, please refer to the technical document "ErP 2009/125/EC DIRECTIVE" in the catalogue introducing pages, or to the EN14825:2017 regulation.

(3) Outdoor air temperature dry bulb 7°C / wet bulb 6°C, water temperature 40°C / 45°C (EN14511:2013)

(4) Seasonal energy efficiency class for MEDIUM TEMPERATURE room heating under AVERAGE climatic conditions [EUROPEAN REGULATION No 811/2013]

(5) Outdoor air temperature 35°C, water temperature 23°C / 18°C (EN14511:2013)

(6) Outdoor air temperature dry bulb 7°C / wet bulb 6°C, water temperature 30°C / 35°C (EN14511:2013)

(7) Sound power level measured according to ISO 9614

(E) EUROVENT certified data

DIMENSIONAL DRAWINGS

MPI DC 010 - 014 - 018

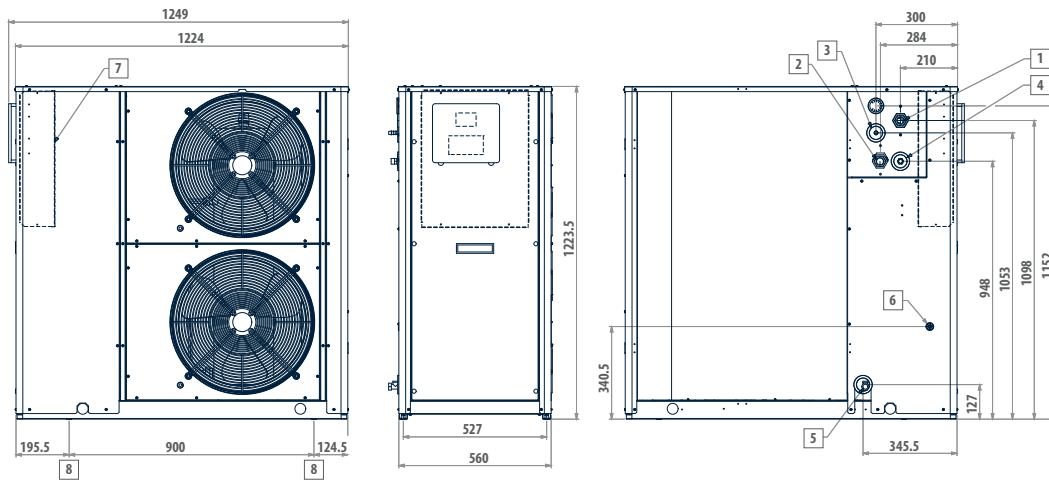

LEGEND

- | | |
|---|--|
| 1 | Water inlet 1" 1/4 female |
| 2 | Water outlet 1" 1/4 female |
| 3 | Safety valve discharge outlet provided with rubber ring holder |
| 4 | Water supply 1/2" male (optional tap) |
| 5 | Water drainage 1/2" female |
| 6 | Power supply \varnothing 28 mm |
| 7 | Electric control board |
| 8 | Fastening points for vibration dampers (accessory) |

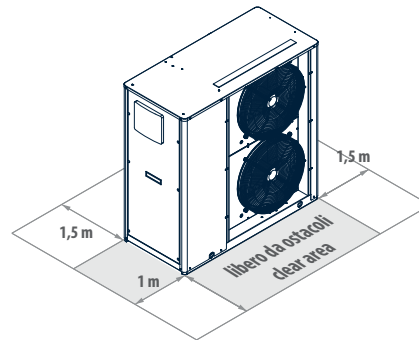

MPI DC 023 - 029

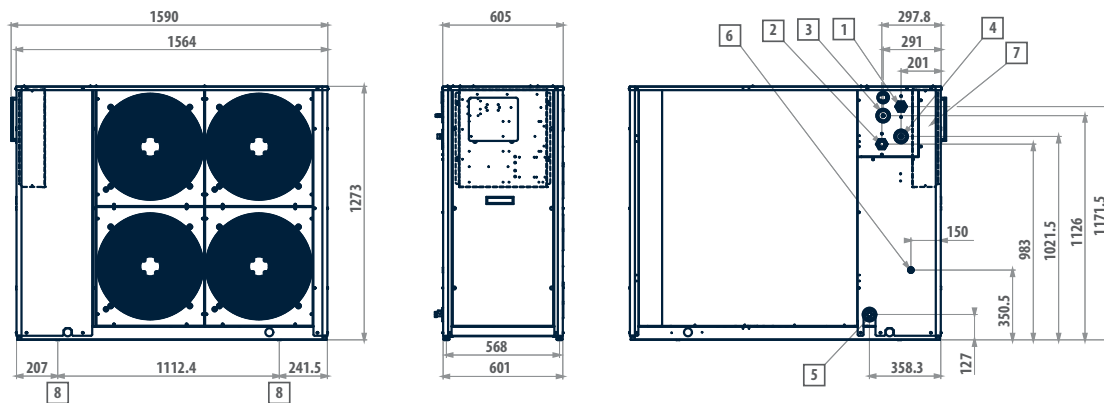

LEGEND

- | | |
|---|--|
| 1 | Water inlet 1" 1/4 female |
| 2 | Water outlet 1" 1/4 female |
| 3 | Safety valve discharge outlet provided with rubber ring holder |
| 4 | Water supply 1/2" male (optional tap) |
| 5 | Water drainage 1/2" female |
| 6 | Power supply \varnothing 28 mm |
| 7 | Electric control board |
| 8 | Fastening points for vibration dampers (accessory) |

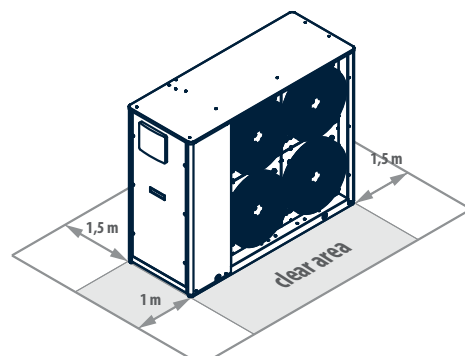

High-efficiency full inverter compact outdoor packaged units

MCI 5 - 19 kW



High efficiency full inverter heat pumps

MCI is a range of heat pumps consisting of 5 unit sizes and 6 models, equipped with a state-of-the-art inverter compressor capable of efficiently meeting the cooling or thermal power requirements of residential or light commercial buildings.

All models, that access to tax deductions provided for by actual law, takes full advantage of some of the most innovative HVAC technologies: in fact, all the units are full-inverter and the extended use of electrical motors with permanent magnets driven by inverters with direct current, even for the accessory components – such as fans and water circulators – drastically reduces electrical power consumption and minimizes it under every operating condition, ensuring an energy efficiency level that puts them solidly in class A+ or A++. Thanks to the advanced management strategies that have been implemented, the control electronics integrate the functioning of the units' key components, thereby optimizing interaction between the main parts: compressor, fan, and water circulator.



PLUS

- » Twin-rotary compressor driven by an electric BLDC motor
- » EC hydraulic pump
- » EC axial fan
- » Access to tax deductions
- » Advanced system management and adjustment strategies

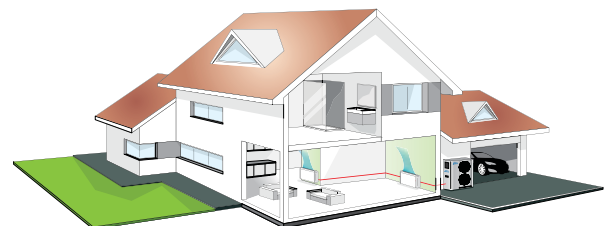

MAIN COMPONENTS



Control unit

The user terminal of the MCI series heat pumps is not a simple remote control, but a sophisticated controller that is capable of extending the basic functions implemented in the unit's electronics. It allows you not only to manage with absolute ease the basic daily functions the machine is intended to provide (on and off, setting the operating mode, instant activation of predefined comfort settings), but also to access advanced programming levels. Customized time slots according to real usage needs and the ability to implement climatic curves on the basis of which to modulate the operation of the unit in order to maximize the overall efficiency of the heating and air-conditioning system, in addition to the ability to manage external equipment such as dehumidifiers, additional hydraulic circulators for primary/secondary loop systems, 3-way valves for the production of domestic hot water and boilers or external backup devices, are just some of the advantages offered to users by this powerful interface. The clear and ergonomic display of the main parameters and the ability to provide in-depth diagnoses of operation are a valuable aid for the maintenance and service operations.

Heat exchanger

Brazed-welded plate condenser in AISI 316 corrosion resistant austenitic stainless steel, specifically developed to maximise heat exchange coefficients between water and refrigerant.



Fan

The sound levels are especially low thanks to the use of a specially designed fan with airfoil blades that is able to ensure a high air flow rate with limited noise emission.

Compressor

Hermetic twin-rotary compressor driven by a permanent magnet BLDC motor and equipped with a double acoustic insulation is fixed to the base by means of vibration-damping supports.

EXTENDED OPERATING RANGE FOR EACH APPLICATION

MCI series heat pumps were designed to ensure maximum flexibility in every application. Thanks to their extremely wide operating range ensuring the operation even in particularly cold climates and allowing them to produce water up to a maximum of 60 °C and to the advanced adjustment logics provided by the electronic control, they are able to ensure not only winter heating and summer air conditioning, but also the production of thermal energy to be used for domestic hot water production. The high efficiency values that characterize them make it possible, in many cases, to cover the share of renewable energy required by the most recent regulations on limiting energy consumption and to benefit from the tax credits offered by the legislation of many countries that are dedicated to promoting equipment that meets the highest standards.

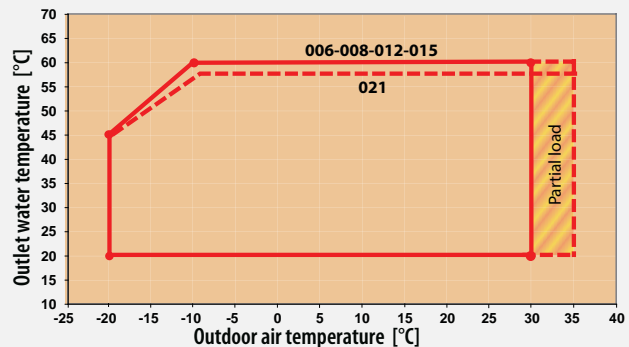
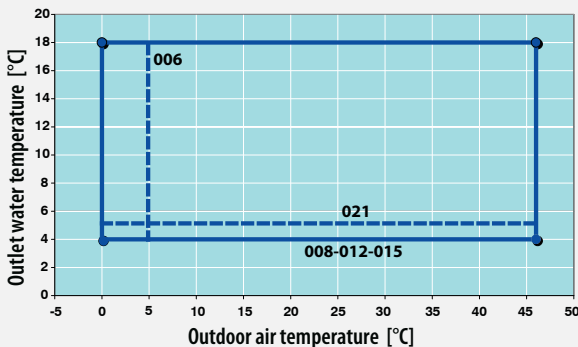

LIGHT COMMERCIAL AND RESIDENCIAL USE: PERFORMANCE AND FUNCTIONALITY ALWAYS ON TOP

The control unit is able to activate an alternative heat generator (boiler or heating element) and employ its operation according to various user-configurable logics in unfavorable weather conditions and particularly high thermal loads, in order to integrate the missing heat capacity or to completely replace heat generation. This feature can also be used during the defrost phases, in order to balance the energy extracted from the heat transfer fluid to melt the ice present on the outside of the heat exchanger, or in the case of machine stoppage due to malfunction or maintenance.

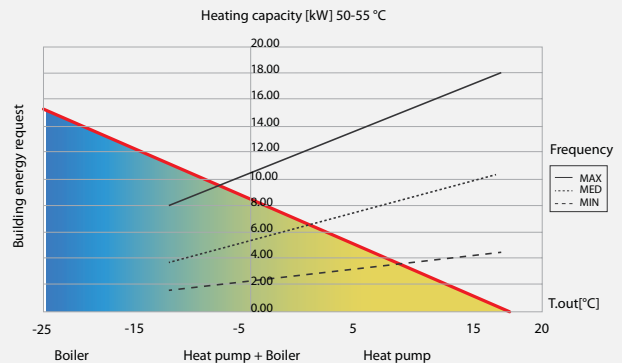

All the models of the MCI range feature extremely compact size and low weight, which allow them to be installed even in environments with high population density and particularly small installation spaces. This is contributed to also by the multi-speed inverter circulator and the expansion tank integrated in the internal hydronic module, thus making superfluous the use of a dedicated technical compartment and in this manner simplifying and speeding up the installation operations. The units' structural metalwork was designed to facilitate maintenance operations and allow easy access to the main internal parts even in the case of limited clearance.

Air chillers and heat pumps MCI

RATED TECHNICAL DATA

MCI		V-ph-Hz	006HM	008HM	012HM	015H0	015HM	021H0
Power supply			230 - 1 - 50	230 - 1 - 50	230 - 1 - 50	400 - 3 - 50	230 - 1 - 50	400 - 3 - 50
Cooling capacity	(1)(E)	kW	4,73	5,84	10,2	13,0	13,0	18,6
Total power input	(1)(E)	kW	1,58	1,96	3,46	4,47	4,42	6,00
EER	(1)(E)		3,00	2,98	2,96	2,91	2,95	3,10
SEER	(2)(E)		4,19	3,85	3,98	4,88	4,30	4,51
Water flow	(1)	l/h	810	992	1750	2237	2237	3201
Available pressure head - LP pumps	(1)(E)	kPa	65	66	76	66	66	74
Heating capacity	(3)(E)	kW	5,76	7,36	12,9	14,5	14,0	20,0
Total power input	(3)(E)	kW	1,89	2,31	4,26	4,39	4,32	6,06
COP	(3)(E)		3,05	3,19	3,03	3,30	3,23	3,30
SCOP	(2)(E)		3,37	2,84	2,95	3,33	3,25	2,90
Heating energy efficiency class	(4)		A++	A+	A+	A++	A++	A+
Water flow	(3)	l/h	996	1281	2238	2439	2439	3470
Available pressure head - LP pumps	(3)(E)	kPa	60	55	72	58	60	74
Cooling capacity	(5)(E)	kW	7,04	7,84	13,5	16,0	16,0	25,8
Total power input	(5)(E)	kW	1,90	1,96	3,70	4,20	4,17	6,79
EER	(5)(E)		3,70	3,99	3,66	3,81	3,85	3,80
Heating capacity	(6)(E)	kW	5,76	7,16	11,9	15,0	14,5	21,1
Total power input	(6)(E)	kW	1,35	1,80	3,00	3,57	3,54	5,15
COP	(6)(E)		4,28	3,97	3,95	4,20	4,09	4,10
Maximum current absorption		A	11	15	21	11	23	16
Compressors / circuits			1 / 1					
Expansion vessel volume		dm ³	2	2	3	3	3	8
Sound power level	(7)(E)	dB(A)	64	65	68	69	69	74
Transport weight - unit with pump		kg	61	69	104	116	112	199
Operating weight - unit with pump		kg	61	69	104	116	112	199

(1) Outdoor air temperature 35°C, water temperature 12°C / 7°C (EN14511:2013)

(2) η efficiency values for heating and cooling are respectively calculated by the following formulas: $[\eta = SCOP / 2,5 - F(1) - F(2)]$ e $[\eta = SEER / 2,5 - F(1) - F(2)]$. For further information, please refer to the technical document "ErP 2009/125/EC DIRECTIVE" in the catalogue introducing pages, or to the EN14825:2017 regulation.

(3) Outdoor air temperature dry bulb 7°C / wet bulb 6°C, water temperature 40°C / 45°C (EN14511:2013)

(4) Seasonal energy efficiency class for MEDIUM TEMPERATURE room heating under AVERAGE climatic conditions [EUROPEAN REGULATION No 811/2013]

(5) Outdoor air temperature 35°C, water temperature 23°C / 18°C (EN14511:2013)

(6) Outdoor air temperature dry bulb 7°C / wet bulb 6°C, water temperature 30°C / 35°C (EN14511:2013)

(7) Sound power level measured according to ISO 9614

(E) EUROVENT certified data

DIMENSIONAL DRAWINGS

MCI 006-008 - MCI 012-015

006-008

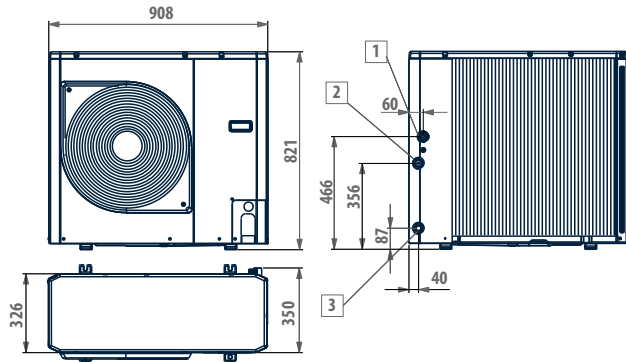

012-015

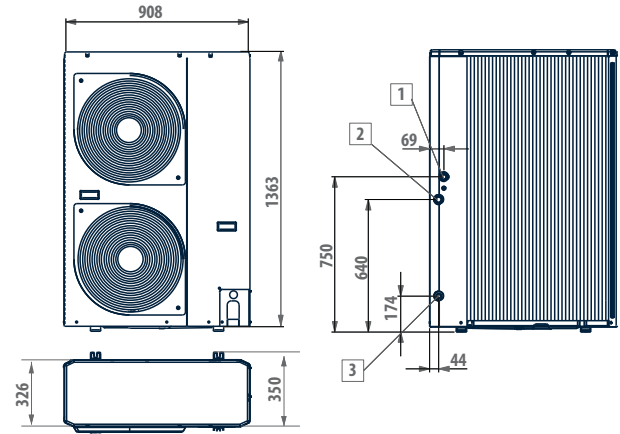

LEGEND

- | | |
|---|-----------------|
| 1 | Water inlet 1" |
| 2 | Water outlet 1" |
| 3 | Water drainage |

MCI 021

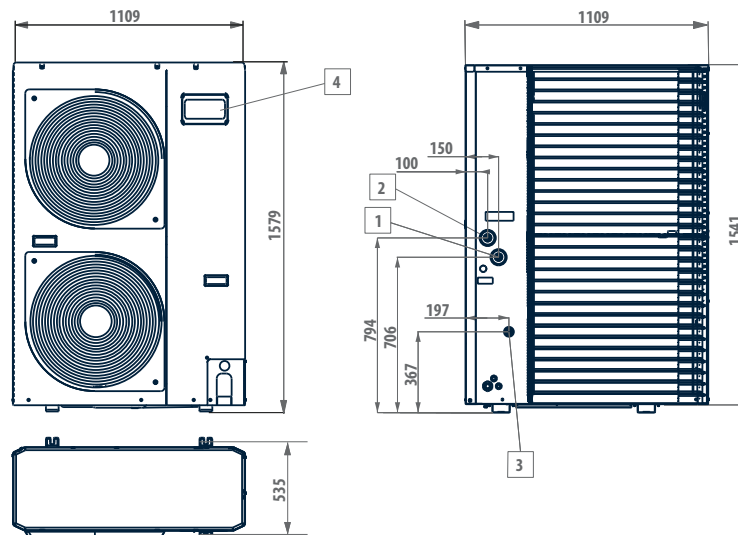

LEGEND

- | | |
|---|--------------------|
| 1 | Water inlet 1" 1/4 |
| 2 | Water outlet 1" |
| 3 | Water drainage |
| 4 | User interface |

Outdoor packaged unit

MPE 4 - 76 kW



PLUS

- » Completely configurable range
- » Dual-compressor version that guarantees high efficiency at partial loads
- » Production of chilled water up to an air temperature of 51 °C
- » Built-in hydronic unit
- » Available ducted version on request

Efficiency under all operating conditions

MPE water chillers and heat pumps are designed for outdoor installation in both residential and industrial applications. The range uses R410A refrigerant, which assures high levels of performance with relatively low energy consumption and features 18 models in the chiller version and 25 models in the heat pump version, with cooling capacities ranging from 9 to 76 kW and heating capacities from 5 to 85 kW.

The finned block heat exchangers have been optimised for R410A and use 8 mm copper pipes, which permit a better heat exchange and quiet operation of the fans. Their generous sizing guarantees the production of chilled water even with outdoor air temperatures as high as 51°C.

In the MPET models, with a double compressor on the same cooling circuit, the working temperature range is extended further and efficiency at partial loads increases. In demanding working conditions the microprocessor controller activates the capacity control mode, doubling the condensing surface available to the single compressor.

The self-adaptive logic allows the setpoint to be adjusted automatically according to the outdoor temperature in order to reduce consumption and broaden the working temperature range.

The unit can also function in systems with a low water content, even without the use of a storage reservoir, thanks to the automatic adjustment which limits the number of compressor starts and thus extends the life of the compressors themselves.

The exclusive Smart Defrost System (optional feature available with the advanced controller) can correctly identify an impairment of performance in the outdoor exchanger due to the formation of ice and minimise the process time in relation to normal operation of the unit.

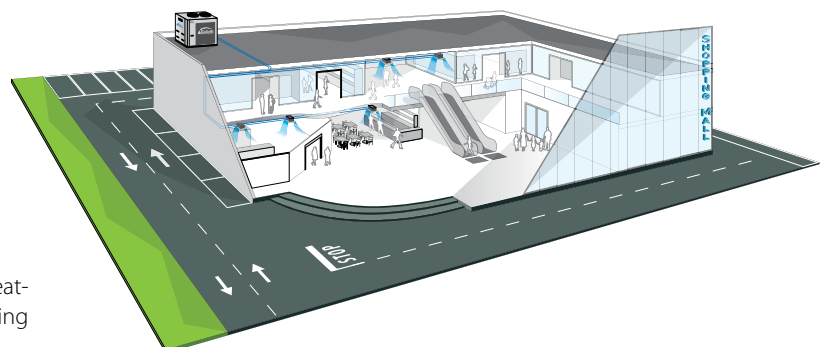

MPE heat pumps and water chillers are designed for heating or cooling the water to be used in air-conditioning systems for residential, commercial or industrial use.

MAIN COMPONENTS

Structure

Painted galvanised sheet steel structure (RAL9002) for an effective resistance to corrosive agents. Fastening devices are made of non-oxidizable carbon steel that has undergone surface-passivating treatments.

Customised hydraulic kit

The structure can accommodate hydronic kits with pump, expansion tank, and buffer tank. High head pump made entirely of stainless steel, already configured for use with mixtures of water and ethylene glycol up to 35% and provided with internal thermal protection.

Fan drive assembly

Electric fan with external rotor motor directly keyed to the axial fan, with internal thermal protection on the windings.

Finned block heat exchanger

Made of 8mm diameter copper pipes and aluminium fins. The heat exchangers' particular design makes it possible to speed up to the maximum the defrost phases in the versions with heat pump with obvious benefits to seasonal efficiency while operating in heating mode.

Electronic microprocessor control

The electronic controller enables the complete control of the MPE unit. It can be easily accessed through a polycarbonate flap with IP65 protection rating. It implements the compressor regulation logic and allows the complete management of the unit's other parts, the reversal of the cooling cycle, and the alarms.



CONFIGURATOR

The models are completely configurable by selecting the version and the options. To the right is shown an example of configuration.

Version	Fields	1	2	3	4	5	6	7	8	9	10	11	12	13
MPE009C0AA		A	1	S	0	E	0	3	M	2	0	G	2	1

AVAILABLE VERSIONS

To verify the compatibility of the options, use the selection software or the price list.

Cooling only versions

MPE..COAA	Unit with 400V - 3N - 50 Hz power supply
MPE..CMAA	Unit with 230V - 1 - 50 Hz power supply
MPE..C2AA	Unit with circuit breakers and 400V - 3N - 50 Hz power supply
MPE..C4AA	Unit with circuit breakers and 230V - 1 - 50 Hz power supply

Versions with reversible heat pump

MPE...HOAA	Unit with 400V - 3N - 50 Hz power supply
MPE...HMAA	Unit with 230V - 1 - 50 Hz power supply
MPE...H2AA	Unit with circuit breakers and 400V - 3N - 50 Hz power supply
MPE...H4AA	Unit with circuit breakers and 230V - 1 - 50 Hz power supply

CONFIGURATION OPTIONS

1 Expansion valve	0 Absent
A Electronic	2 RS485 serial board (Carel / Modbus protocol)
B Floor Pack (electronic expansion valve included)	B BACNET IP / PCOWEB serial board (advanced controller required)
2 Water pump and accessories	F BACNET MS/TP / PCONET board (advanced control required)
1 LP pump + expansion vessel	G BACNET IP / PCOWEB serial board + supervision software Gweb (advanced controller required)
2 LP run and standby double pump + expansion vessel	L LON FTT10 serial board (advanced controller required)
3 Water buffer tank	M Remote simplified user panel for standard controller
0 Absent	S Remote simplified user panel
S Selected	X Remote simplified user panel for advanced controller
4 Partial heat recovery	10 Special coils / Protective treatments
0 Absent	0 Standard
D Desuperheater with pump activation contact	B Pre-painted fins with epoxy painting
5 Air flow modulation	C Cataphoresis
C Condensation control by phase-cut fans	R Copper-copper
E Condensation control performed by EC fans	11 Outdoor finned coil heat exchanger protection
6 Antifreezing kit	0 Absent
0 Absent	G Outdoor finned coil heat exchanger protection grille
E Evaporator	12 Compressors options
P Evaporator and water pump	0 Absent
S Evaporator, water pump and water buffer tank	1 Power factor capacitors
7 Acoustic insulation and attenuation	2 Soft starter
0 Absent	3 Power factor capacitors + soft starter
1 Compressor compartment acoustic insulation	4 Crankcase compressor heater (CHILLER), outdoor coil trace heater (HP)
2 Compressor sound blanket	13 Onboard controller
3 Compressor compartment acoustic insulation and sound blanket	1 Basic
8 Refrigerant pipework accessories	2 Advanced
0 Absent	3 Advanced + GSM modem board
M Refrigerant pressure gauges	4 Advanced + clock card
9 Remote control / Serial communication	

ACCESSORIES

1701546	Remote simplified user panel	RYPAM	Rubber anti vibration shock mounts
RYKAMF	Spring anti vibration shock mounts	RYRT40	Tank module connection kit
RYMCL	MyChiller Plus (RS485 serial board required)	RYT40	Inertial tank module for under-base installation
RYMCM	MyChiller Base (RS485 serial board required)		

RATED TECHNICAL DATA MPE C

MPE C		009	012	014	019	023	027	028
Power supply	V-ph-Hz	400 - 3 - 50						
Cooling capacity	(1)(E) kW	9,20	12,3	14,3	19,7	22,5	26,4	27,9
Total power input	(1)(E) kW	2,97	3,69	4,80	6,60	7,53	9,52	8,87
EER	(1)(E)	3,10	3,33	2,98	2,98	2,99	2,77	3,15
SEER	(2)(E)	3,80	4,10	3,80	3,80	3,80	3,80	3,99
Water flow	(1) l/h	1590	2217	2571	3373	4090	4565	4823
Water pressure drop	(1)(E) kPa	34	61	38	51	49	34	40
Available pressure head - LP pumps	(1) kPa	115	81	102	123	113	123	141
Maximum current absorption	A	12	15	18	24	26	32	33
Star up current	A	49	64	67	105	159	133	134
Star up current with soft starter	A	33	44	46	72	110	91	91
Compressors / circuits		1 / 1						
Expansion vessel volume	dm ³	5	5	5	5	5	5	8
Buffer tank volume	dm ³	30	30	30	50	50	50	125
Sound power level	(3)(E) dB(A)	69	69	69	71	72	72	73
Transport weight unit with pump and tank	kg	211	216	219	281	297	313	427
Operating weight unit with pump and full tank	kg	227	232	236	317	333	350	534

MPE C		T30	032	T34	035	040	T40	T44
Power supply	V-ph-Hz	400 - 3 - 50						
Cooling capacity	(1)(E) kW	29,8	31,3	33,9	34,7	39,4	39,3	43,8
Total power input	(1)(E) kW	10,6	10,3	12,8	11,7	13,0	13,9	15,1
EER	(1)(E)	2,81	3,04	2,65	2,97	3,03	2,83	2,90
SEER	(2)(E)	3,88	3,98	3,80	3,82	3,87	3,95	4,18
Water flow	(1) l/h	5156	5415	5854	6008	6816	6799	7648
Water pressure drop	(1)(E) kPa	30	51	38	40	43	45	57
Available pressure head - LP pumps	(1) kPa	148	123	133	128	117	116	94
Maximum current absorption	A	37	34	43	39	40	47	63
Star up current	A	86	167	96	162	164	127	150
Star up current with soft starter	A	64	114	71	111	112	93	110
Compressors / circuits		2 / 1	1 / 1	2 / 1	1 / 1	1 / 1	2 / 1	2 / 1
Expansion vessel volume	dm ³	8	8	8	8	8	8	8
Buffer tank volume	dm ³	125	125	125	125	125	125	125
Sound power level	(3)(E) dB(A)	72	73	72	73	75	72	72
Transport weight unit with pump and tank	kg	448	456	484	487	516	521	555
Operating weight unit with pump and full tank	kg	555	563	591	595	624	629	663

(1) Outdoor air temperature 35°C, water temperature 12°C / 7°C (EN14511:2013)

(2) η efficiency values for heating and cooling are respectively calculated by the following formulas: $\eta = SCOP / 2,5 - F(1) - F(2)$ e $\eta = SEER / 2,5 - F(1) - F(2)$. For further information, please refer to the technical document "ErP 2009/125/EC DIRECTIVE" in the catalogue introducing pages, or to the EN14825:2017 regulation.

(3) Sound power level measured according to ISO 9614

(E) EUROVENT certified data

RATED TECHNICAL DATA MPE C

MPE C			T54	T61	T69	T76
Power supply		V-ph-Hz	400 - 3 - 50			
Cooling capacity	(1)(E)	kW	54,2	61,4	69,3	75,6
Total power input	(1)(E)	kW	18,7	21,7	24,1	28,0
EER	(1)(E)		2,90	2,83	2,88	2,70
SEER	(2)(E)		4,01	3,95	3,93	4,01
Water flow	(1)	l/h	9378	10629	11989	13075
Water pressure drop	(1)(E)	kPa	53	66	52	60
Available pressure head - LP pumps	(1)	kPa	136	119	127	115
Maximum current absorption		A	48	53	57	69
Star up current		A	177	187	202	229
Star up current with soft starter		A	130	138	149	169
Compressors / circuits			2 / 1			
Expansion vessel volume		dm ³	8	8	8	8
Buffer tank volume		dm ³	125	125	125	125
Sound power level	(3)(E)	dB(A)	81	81	81	81
Transport weight unit with pump and tank		kg	643	665	685	786
Operating weight unit with pump and full tank		kg	751	773	793	894

(1) Outdoor air temperature 35°C, water temperature 12°C / 7°C (EN14511:2013)

(2) η efficiency values for heating and cooling are respectively calculated by the following formulas: $[\eta = SCOP / 2,5 - F(1) - F(2)]$ e $[\eta = SEER / 2,5 - F(1) - F(2)]$. For further information, please refer to the technical document "ErP 2009/125/EC DIRECTIVE" in the catalogue introducing pages, or to the EN14825:2017 regulation.

(3) Sound power level measured according to ISO 9614

(E) EUROVENT certified data

RATED TECHNICAL DATA MPE H

MPE H			004M	005M	007M	008	008M	010	010M	
Power supply		V-ph-Hz	230 - 1 - 50	230 - 1 - 50	230 - 1 - 50	400 - 3 - 50	230 - 1 - 50	400 - 3 - 50	230 - 1 - 50	
Cooling capacity	(1)(E)	kW	4,02	4,99	6,51	8,26	8,13	8,99	8,98	
Total power input	(1)(E)	kW	1,35	1,71	2,28	3,11	3,38	3,31	3,31	
EER	(1)(E)		2,98	2,92	2,86	2,66	2,41	2,72	2,71	
SEER	(2)(E)		3,16	3,02	3,06	3,17	2,98	3,15	3,15	
Water flow	(1)	l/h	692	859	1122	1423	1400	1559	1557	
Water pressure drop	(1)(E)	kPa	5	5	6	6	6	33	33	
Available pressure head - LP pumps	(1)	kPa	77	74	70	67	67	115	115	
Heating capacity	(3)(E)	kW	4,73	5,88	7,79	9,93	10,3	11,0	11,0	
Total power input	(3)(E)	kW	1,47	1,83	2,44	3,26	3,66	3,73	3,73	
COP	(3)(E)		3,22	3,21	3,19	3,05	2,81	2,95	2,95	
SCOP	(2)(E)		3,45	3,59	3,59	3,51	3,26	3,34	3,34	
Heating energy efficiency class	(4)(E)								A+	
Water flow	(3)	l/h	820	1020	1348	1720	1788	1884	1884	
Water pressure drop	(3)(E)	kPa	5	5	8	8	8	46	46	
Available pressure head - LP pumps	(3)	kPa	75	73	66	63	63	104	104	
Maximum current absorption		A	9	11	15	9	24	12	24	
Star up current		A	38	44	63	49	98	49	98	
Star up current with soft starter		A	26	30	44	34	68	33	68	
Compressors / circuits									1 / 1	
Expansion vessel volume		dm ³	1	1	1	1	1	5	5	
Buffer tank volume		dm ³	20	20	20	20	20	30	30	
Sound power level	(5)(E)	dB(A)	66	66	67	67	67	69	69	
Transport weight unit with pump and tank		kg	114	118	123	127	127	211	211	
Operating weight unit with pump and full tank		kg	123	127	132	136	136	227	227	

MPE H			013	015	018	020	024	027	028	
Power supply		V-ph-Hz	400 - 3 - 50							
Cooling capacity	(1)(E)	kW	12,5	14,5	16,7	19,1	23,1	25,9	27,3	
Total power input	(1)(E)	kW	4,31	5,28	6,51	7,30	8,31	9,51	8,86	
EER	(1)(E)		2,90	2,75	2,57	2,62	2,78	2,72	3,08	
SEER	(2)(E)		3,45	3,39	3,17	3,14	3,32	3,32	3,71	
Water flow	(1)	l/h	2172	2520	2894	3306	4008	4474	4727	
Water pressure drop	(1)(E)	kPa	59	36	49	49	47	32	39	
Available pressure head - LP pumps	(1)	kPa	81	102	130	123	113	123	141	
Heating capacity	(3)(E)	kW	15,4	17,8	20,3	23,1	27,4	30,1	31,5	
Total power input	(3)(E)	kW	4,92	5,66	6,87	7,42	8,38	9,11	9,38	
COP	(3)(E)		3,13	3,14	2,95	3,11	3,27	3,30	3,36	
SCOP	(2)(E)		3,34	3,47	3,22	3,22	3,44	3,57	3,60	
Heating energy efficiency class	(4)(E)								A+	
Water flow	(3)	l/h	2628	3053	3493	3976	4721	5187	5431	
Water pressure drop	(3)(E)	kPa	85	52	71	70	63	43	50	
Available pressure head - LP pumps	(3)	kPa	59	87	107	101	93	106	127	
Maximum current absorption		A	15	18	22	24	26	32	33	
Star up current		A	64	67	76	105	159	133	134	
Star up current with soft starter		A	44	46	51	72	110	91	91	
Compressors / circuits									1 / 1	
Expansion vessel volume		dm ³	5	5	5	5	5	5	8	
Buffer tank volume		dm ³	30	30	50	50	50	50	125	
Sound power level	(5)(E)	dB(A)	69	69	71	71	72	72	73	
Transport weight unit with pump and tank		kg	216	219	265	281	297	313	427	
Operating weight unit with pump and full tank		kg	232	236	301	317	333	350	534	

(1) Outdoor air temperature 35°C, water temperature 12°C / 7°C (EN14511:2013)

(2) η efficiency values for heating and cooling are respectively calculated by the following formulas: $\eta = SCOP / 2,5 - F(1) - F(2)$ e $\eta = SEER / 2,5 - F(1) - F(2)$. For further information, please refer to the technical document "ErP 2009/125/EC DIRECTIVE" in the catalogue introducing pages, or to the EN14825:2017 regulation.

(3) Outdoor air temperature dry bulb 7°C / wet bulb 6°C, water temperature 40°C / 45°C (EN14511:2013)

(4) Seasonal energy efficiency class for LOW TEMPERATURE room heating under AVERAGE climatic conditions [EUROPEAN REGULATION No 811/2013]

(5) Sound power level measured according to ISO 9614

(E) EUROVENT certified data

RATED TECHNICAL DATA MPE H

MPE H			T30	032	T34	035	040	T40	T45	
Power supply		V-ph-Hz	400 - 3 - 50							
Cooling capacity	(1)(E)	kW	29,3	30,6	33,2	34,0	38,6	38,5	43,3	
Total power input	(1)(E)	kW	10,6	10,3	12,8	11,7	13,0	13,9	16,7	
EER	(1)(E)		2,76	2,97	2,59	2,91	2,97	2,77	2,59	
SEER	(2)(E)		3,85	3,58	3,78	3,58	3,66	3,88	3,76	
Water flow	(1)	l/h	5053	5307	5737	5888	6681	6663	7495	
Water pressure drop	(1)(E)	kPa	29	49	37	39	42	44	55	
Available pressure head - LP pumps	(1)	kPa	148	123	133	128	117	116	94	
Heating capacity	(3)(E)	kW	34,6	35,9	39,5	39,5	45,2	46,7	53,2	
Total power input	(3)(E)	kW	11,1	10,8	13,1	11,9	13,5	14,3	16,7	
COP	(3)(E)		3,12	3,32	3,02	3,32	3,35	3,27	3,19	
SCOP	(2)(E)		3,54	3,64	3,70	3,70	3,64	3,73	3,68	
Heating energy efficiency class	(4)(E)		A+							
Water flow	(3)	l/h	5976	6173	6818	6813	7800	8042	9155	
Water pressure drop	(3)(E)	kPa	39	64	52	51	54	58	74	
Available pressure head - LP pumps	(3)	kPa	131	109	113	114	99	95	65	
Maximum current absorption		A	37	34	43	39	40	47	63	
Star up current		A	86	167	96	162	164	127	150	
Star up current with soft starter		A	64	114	71	111	112	93	110	
Compressors / circuits			2 / 1	1 / 1	2 / 1	1 / 1	1 / 1	2 / 1	2 / 1	
Expansion vessel volume		dm ³	8	8	8	8	8	8	8	
Buffer tank volume		dm ³	125	125	125	125	125	125	125	
Sound power level	(5)(E)	dB(A)	72	73	72	73	75	72	72	
Transport weight unit with pump and tank		kg	448	456	484	487	516	521	555	
Operating weight unit with pump and full tank		kg	555	563	591	595	624	629	663	

MPE H			054	T54	T61	066	T69	T76
Power supply		V-ph-Hz	400 - 3 - 50					
Cooling capacity	(1)(E)	kW	51,6	53,1	60,2	62,3	68,1	74,1
Total power input	(1)(E)	kW	18,2	18,7	21,7	24,6	24,0	28,0
EER	(1)(E)		2,84	2,84	2,77	2,53	2,84	2,65
SEER	(2)(E)		3,57	3,77	3,78	3,18	3,42	3,97
Water flow	(1)	l/h	8932	9189	10423	10776	11766	12818
Water pressure drop	(1)(E)	kPa	56	51	64	54	50	58
Available pressure head - LP pumps	(1)	kPa	107	136	119	92	127	115
Heating capacity	(3)(E)	kW	61,4	60,4	68,1	75,8	77,0	85,4
Total power input	(3)(E)	kW	18,9	19,0	22,1	23,8	23,9	27,4
COP	(3)(E)		3,25	3,18	3,08	3,18	3,22	3,12
SCOP	(2)(E)		3,58	3,55	3,47	3,48	3,67	3,56
Heating energy efficiency class	(4)(E)		A+					
Water flow	(3)	l/h	10575	10412	11733	13063	13292	14730
Water pressure drop	(3)(E)	kPa	82	58	74	81	56	69
Available pressure head - LP pumps	(3)	kPa	76	126	100	52	110	87
Maximum current absorption		A	40	48	53	41	57	69
Star up current		A	163	177	187	165	202	229
Star up current with soft starter		A	110	130	138	112	149	169
Compressors / circuits			1 / 1	2 / 1	2 / 1	1 / 1	2 / 1	2 / 1
Expansion vessel volume		dm ³	8	8	8	8	8	8
Buffer tank volume		dm ³	125	125	125	125	125	125
Sound power level	(5)(E)	dB(A)	78	81	81	78	81	81
Transport weight unit with pump and tank		kg	521	643	665	558	685	786
Operating weight unit with pump and full tank		kg	630	751	773	665	793	894

(1) Outdoor air temperature 35°C, water temperature 12°C / 7°C (EN14511:2013)

(2) η efficiency values for heating and cooling are respectively calculated by the following formulas: $[\eta = SCOP / 2,5 - F(1) - F(2)]$ e $[\eta = SEER / 2,5 - F(1) - F(2)]$. For further information, please refer to the technical document "ErP 2009/125/EC DIRECTIVE" in the catalogue introducing pages, or to the EN14825:2017 regulation.

(3) Outdoor air temperature dry bulb 7°C / wet bulb 6°C, water temperature 40°C / 45°C (EN14511:2013)

(4) Seasonal energy efficiency class for LOW TEMPERATURE room heating under AVERAGE climatic conditions [EUROPEAN REGULATION No 811/2013]

(5) Sound power level measured according to ISO 9614

(E) EUROVENT certified data

DIMENSIONAL DRAWINGS

MPE 4 - 8

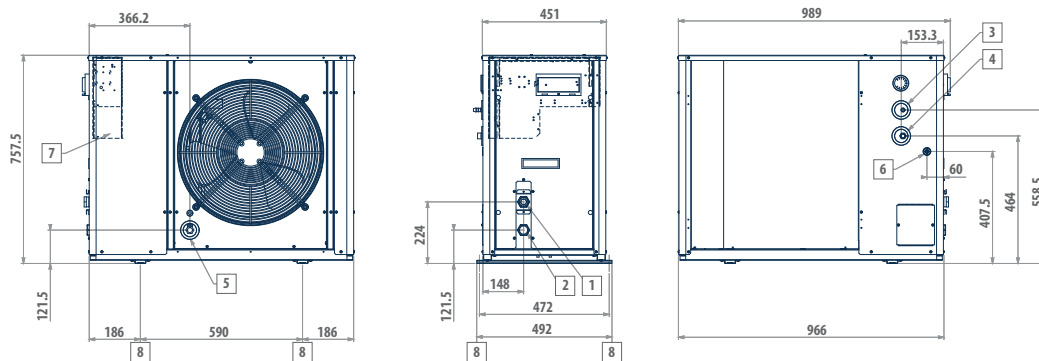

LEGEND

1	Water inlet 1" female
2	Water outlet 1" female
3	Safety valve discharge outlet provided with rubber ring holder
4	Water supply 1/2" male (optional tap)
5	Water drainage 1/2" female
6	Power supply \varnothing 28 mm
7	Electric control board
8	Fastening points for vibration dampers (accessory)

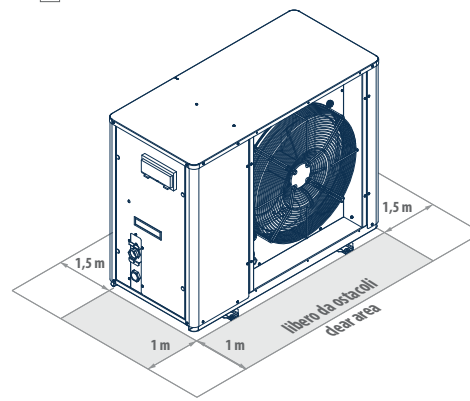

MPE 9 - 15

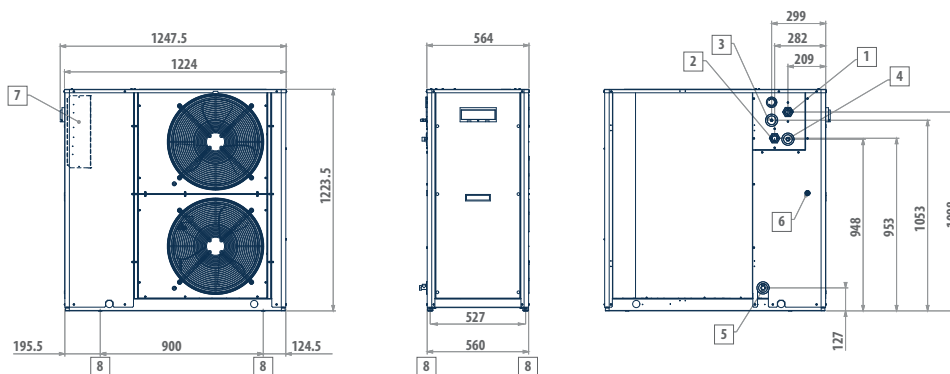

LEGEND

1	Water inlet 1" 1/4 female
2	Water outlet 1" 1/4 female
3	Safety valve discharge outlet provided with rubber ring holder
4	Water supply 1/2" male (optional tap)
5	Water drainage 1/2" female
6	Power supply \varnothing 28 mm
7	Electric control board
8	Vibration dampers

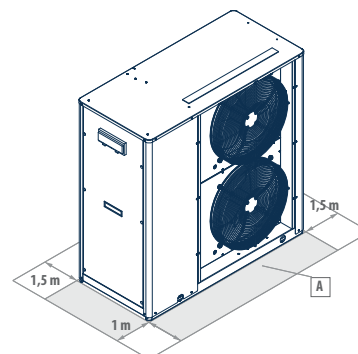

DIMENSIONAL DRAWINGS

MPE 18 - 27

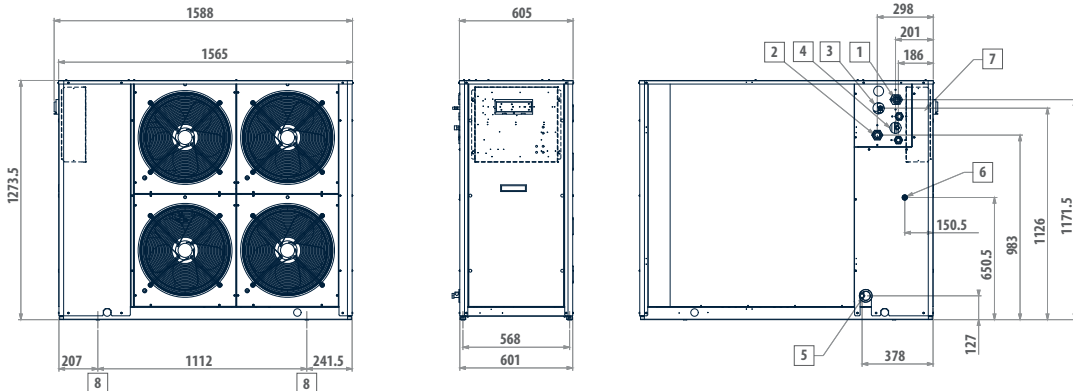

LEGEND

1	Water inlet 1" 1/4 female
2	Water outlet 1" 1/4 female
3	Safety valve discharge outlet provided with rubber ring holder
4	Water supply 1/2" male (optional tap)
5	Water drainage 1/2" female
6	Power supply \varnothing 28 mm
7	Electric control board
8	Vibration dumpers

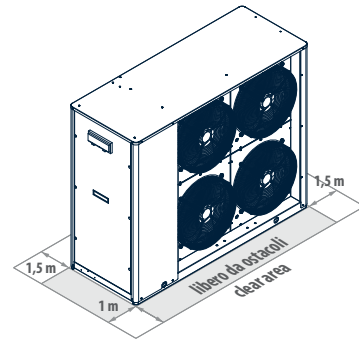

MPE 28 - 40 - MPE T30 - T45

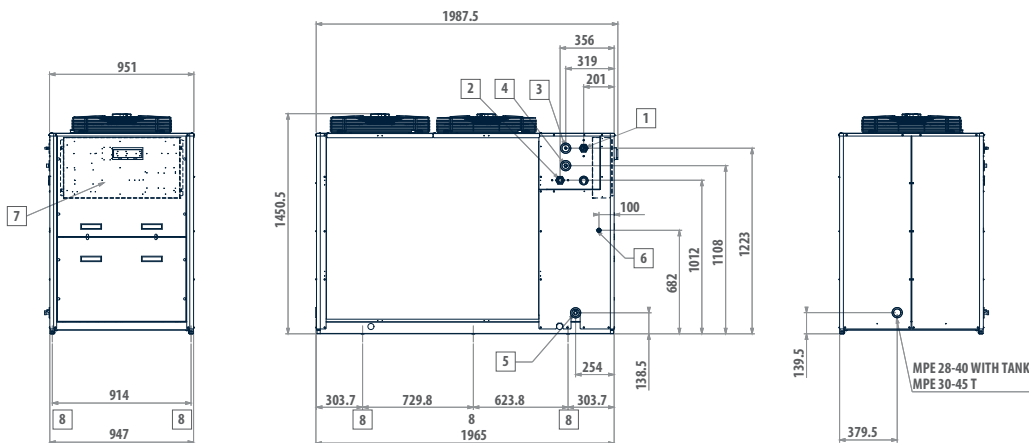

LEGEND

1	Water inlet 1" 1/4 female
2	Water outlet 1" 1/4 female
3	Safety valve discharge outlet provided with rubber ring holder
4	Water supply 1/2" male (optional tap)
5	Water drainage 1/2" female
6	Power supply \varnothing 37 mm
7	Electric control board
8	Vibration dumpers

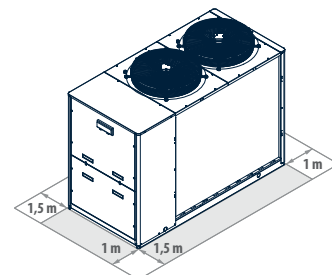

DIMENSIONAL DRAWINGS

MPE 54 ÷ 66

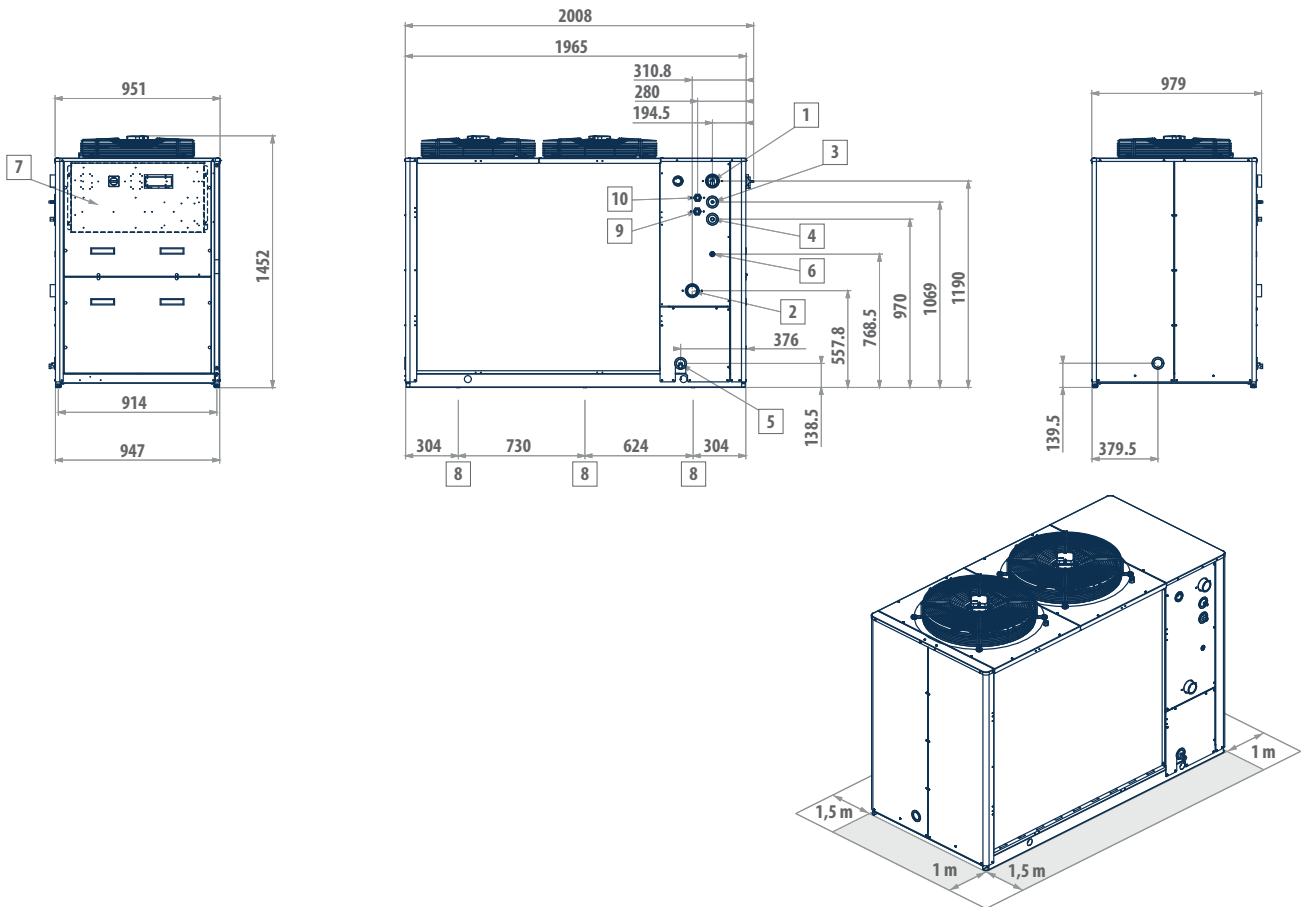

LEGEND

1	Water inlet 2" female
2	Water outlet 2" female
3	Safety valve discharge outlet provided with rubber ring holder
4	Water supply 1/2" male
5	Water drainage 1/2" female
6	Power supply
7	Electric control board
8	Fastening points for vibration dampers (accessory)
9	Desuperheater water inlet 1" female
10	Desuperheater water outlet 1" female

DIMENSIONAL DRAWINGS

MPE T54 ÷ T76

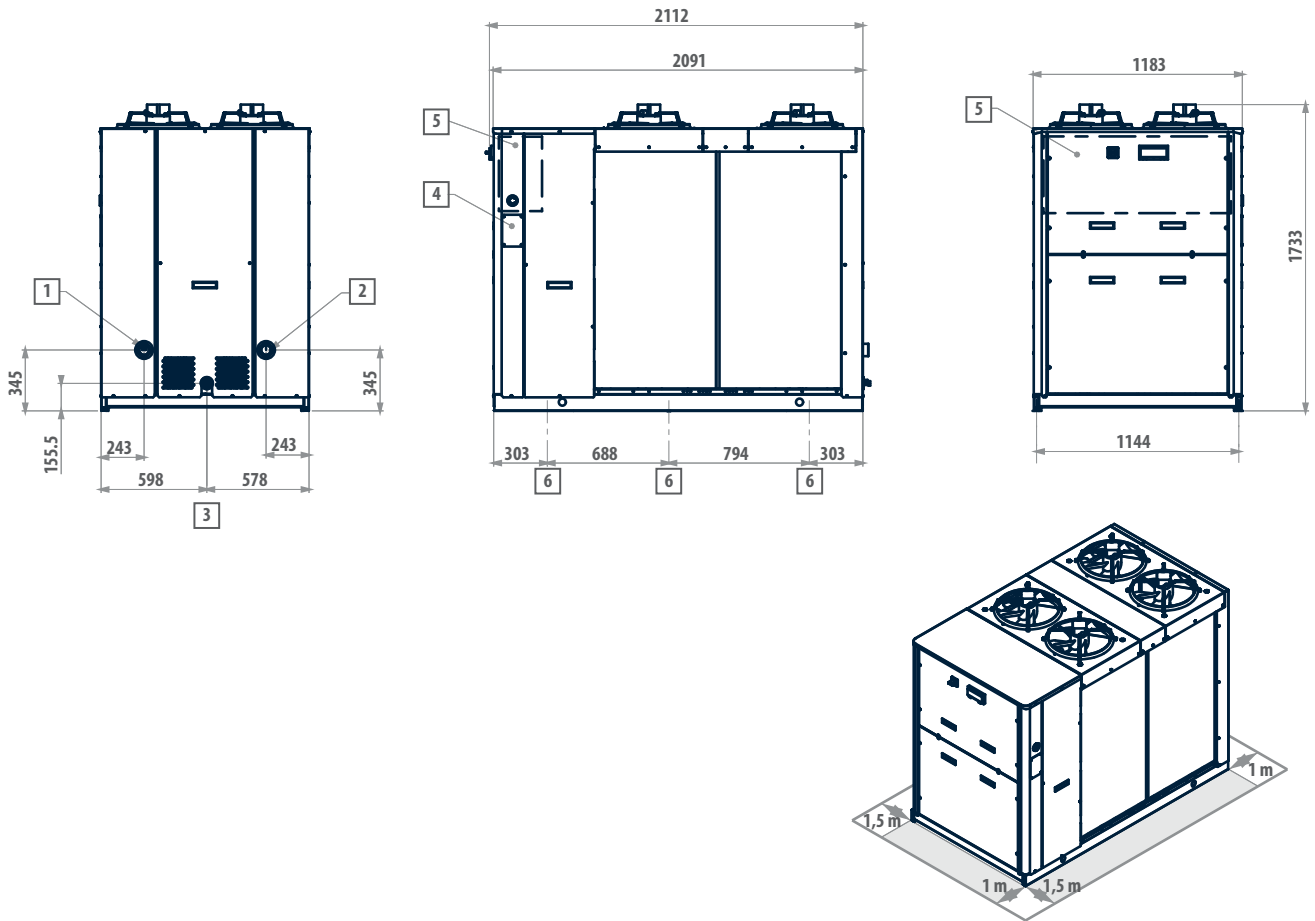

LEGEND

- | | |
|---|--|
| 1 | Water inlet 2" female |
| 2 | Water outlet 2" female |
| 3 | Water drainage 1/2" female |
| 4 | Power supply |
| 5 | Electric control board |
| 6 | Fastening points for vibration dampers |

Air heat pumps with wide working range Evitech

Outdoor packaged unit

EvitechH 50 - 180 kW



Available from SEPTEMBER 2018



Reliability and efficiency in every climatic condition

EvitechH is Galletti's new high efficiency multiscroll units equipped with R410A steam injection compressor. The range consists of 10 air-water models available as chiller and heat pump, with cooling capacities from 50 to 180 kW.

The main strongpoint of this series is the large operating field, both in terms of maximum hot water temperature (65°C with -11°C of external air temperature) and minimum air temperature at which the continuous operation is allowed (-20°C)

The range allows high configurability from an acoustic point of view, having a wide range of accessories designed to reduce noise emissions. The advanced control, always present in the whole range, allows a continuous monitoring of the operating parameters, advanced adjustment logics, and connectivity.

The modular structure with V configuration condensing coils is designed to optimize air-side heat exchange, to ensure structural strength with a reduced footprint, and to maintain maximum accessibility to the basic components.

In addition to high efficiency in terms of nominal conditions (Eurovent A-class), in order to increase the efficiency at partial loads, the whole range consists of tandem solutions (2 compressors on a single refrigerant circuit). The configuration of units with the Hydro Smart Flow kit allows an increase of the efficiency and extends the working area of the cooling mode.



PLUS

- » Class A in heat pump operating mode
- » Production of hot water up to 65°C
- » Full load operation up to -20°C outside air temperature
- » High efficiency under part load conditions
- » Possibility to configure low-noise versions
- » Counterflow solutions in every operating mode

EvitechH heat pumps are designed for heating or cooling the water to be used in air-conditioning systems for residential, commercial or industrial use. The execution with injection steam compressors (EVI) guarantees the production of hot water at high temperatures even in very hard outdoor conditions (outdoor air temperature down to -20°C).

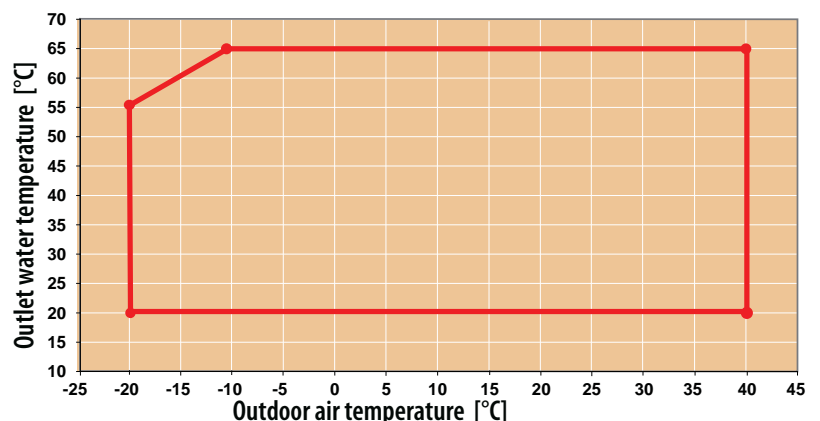

MAIN COMPONENTS

Structure

The range, starting from size 72, is designed modularly, replicating the optimized structure of V configuration condensing coils and fans. Its design ensures stability, sturdiness even during the most critical phases (such as transportation), and maximum accessibility to components in every unit.

Hydro smart flow

The HSF kit (standard for models 52 and 62) is placed on the unit's hydronic side and consists of a 4-way valve and a kit. Hydro Smart Flow, which is activated at the time of seasonal changeover, reverses the direction of the water flow over the plates to be consistent with the flow of the refrigerant. In this manner heat exchange always occurs in counterflow, this optimizing the unit's operation in the summer and winter seasons and extending the unit's operating range.

Upwind

Evitech is designed with an innovative technology which allows the refrigerant to get into the battery from the same direction when the cycle is inverted, with a constant counter-current exchange with air. This advanced technology considerably reduces the risk of ice generation on the finned heat exchangers.

Scroll compressors with vapour injection

The range consists of single and dual-circuit models in order to offer maximum redundancy. The distribution of load in multiple power steps and the use of tandem solutions (2 compressors on a single circuit) ensures maximum efficiency at partial loads and therefore greatly increases seasonal efficiency. Intercooled compression with steam injection allows a better control of the end-compression temperature, keeping it within the limits imposed by the compressor envelope, even in the most unfavorable working conditions (low evaporation pressures and high compression pressures), this results in one of the largest operating field in the market.

3-way valve

This is a smart kit able to convert Evitech heat pumps in multi-function units in order to fulfill every necessity of the hydraulic air-conditioning plant. It allows domestic hot water priority production thanks to Galletti thermal accumulators of the TP or TN series. The switching of the valve is managed by the on-board microprocessor control of the unit.

CONFIGURATOR

The models are completely configurable by selecting the version and the options. To the right is shown an example of configuration.

Version	Fields	1	2	3	4	5	6	7	8	9	10	11	12	13
EVI082HS0A		A	1	S	0	C	0	2	M	0	P	0	0	2

AVAILABLE VERSIONS

Versions with reversible heat pump

EVI..HS0A	400V-3N-50Hz power supply + circuit breakers
EVI..HS1A	400V-3-50Hz power supply + transformer + circuit breakers
EVI..HS2A	400V-3N-50Hz power supply + circuit breakers

To verify the compatibility of the options, use the selection software or the price list.

CONFIGURATION OPTIONS

- | | |
|--|--|
| <p>1 Expansion valve</p> <ul style="list-style-type: none"> 0 Mechanical A Electronic <p>2 Water pump and accessories</p> <ul style="list-style-type: none"> 0 Absent 1 LP pump + expansion vessel 2 LP run and standby double pump + expansion vessel 3 HP pump + expansion vessel 4 HP run and standby double pump + expansion vessel A LP inverter pump + expansion vessel B LP run and standby double inverter pump + expansion vessel C HP inverter pump + expansion vessel D HP run and standby double inverter pump + expansion vessel <p>3 Water buffer tank</p> <ul style="list-style-type: none"> 0 Absent H Present + Hydro smart flow S Selected <p>4 Partial heat recovery</p> <ul style="list-style-type: none"> 0 Absent D Desuperheater with water pump free contact <p>5 Air flow modulation</p> <ul style="list-style-type: none"> C Condensation control by phase-cut fans E Condensation control performed by EC fans <p>6 Antifreezing kit</p> <ul style="list-style-type: none"> 0 Absent E Plate exchanger P Plate exchanger and water pump S Plate exchanger, water pump and inertial tank <p>7 Acoustic insulation and attenuation</p> <ul style="list-style-type: none"> 0 Absent 1 Compressor sound blanket and compressor compartment sound proofing 2 Fans noise reduction (AXITOP) | <ul style="list-style-type: none"> 3 Fans noise reduction (AXITOP) + compressor sound blanket + compartment acoustic insulation <p>8 Refrigerant pipework accessories</p> <ul style="list-style-type: none"> 0 Absent M Refrigerant pressure gauges <p>9 Remote control / Serial communication</p> <ul style="list-style-type: none"> 0 Absent 2 RS485 serial board (Carel / Modbus protocol) B BACNET IP / PCOWEB serial board F BACNET MS/TP / PCONET serial board G BACNET IP / PCOWEB serial board + supervision software Gweb L LON FTT10 serial board S Remote simplified user panel T Touch screen remote user panel X Remote user panel for advanced controller <p>10 Special coils / Protective treatments</p> <ul style="list-style-type: none"> 0 Standard C Cataphoresis I Hydrophilic P Pre-painted fins with epoxy painting R Copper-copper <p>11 Anti vibration shock mounts</p> <ul style="list-style-type: none"> 0 Absent G Rubber anti vibration shock mounts M Spring anti vibration shock mounts <p>12 Coil protection grill</p> <ul style="list-style-type: none"> 0 Absent F Outdoor finned coil heat exchanger protection filters G Selected <p>13 Onboard controller</p> <ul style="list-style-type: none"> 1 Advanced 2 Advanced + touchscreen user panel + USB |
|--|--|

ACCESSORIES

A	3 way valve for DHW production	G	Soft starter
B	Hydro smart flow (water tank not allowed)	H	Power factor capacitors
C	Pair of couplings Victaulic	I	Filter isolation valves kit (solenoid valve and isolation valve)
D	ON/OFF status of the compressors	M	0-10 V signal for external user pump control (on-board pump excluded)
E	Remote control for step capacity limit	N	Compressor tandem/trio isolation valves
F	Configurable digital alarm board	O	Anti-intrusion grille

Air heat pumps with wide working range Evitech

EVITECH HEAT PUMPS RATED TECHNICAL DATA

Evitech			052	062	072	082	092
Power supply		V-ph-Hz	400 - 3N - 50				
Cooling capacity	(1)(E)	kW	50,3	60,7	71,0	80,0	90,3
Total power input	(1)(E)	kW	17,9	21,4	24,2	27,0	31,3
EER	(1)(E)		2,80	2,84	2,94	2,96	2,88
SEER	(2)(E)		3,68	3,68	3,83	3,80	3,85
Water flow	(1)	l/h	8675	10485	12269	13823	15588
Water pressure drop	(1)(E)	kPa	21	30	29	37	27
Available pressure head - LP pumps	(1)	kPa	171	155	150	194	189
Heating capacity	(3)(E)	kW	59,9	70,5	83,1	92,4	105
Total power input	(3)(E)	kW	18,2	21,2	25,5	27,9	31,5
COP	(3)(E)		3,30	3,33	3,25	3,31	3,32
SCOP	(2)(E)		2,81	2,89	2,88	2,93	2,96
Heating energy efficiency class	(4)		A+				
SCOP	(2)		3,52	3,60	3,50	3,58	3,61
Heating energy efficiency class	(5)		A+				
Water flow	(3)	l/h	10247	12066	14219	15795	17924
Water pressure drop	(3)(E)	kPa	29	41	39	49	35
Available pressure head - LP pumps	(3)	kPa	156	135	128	165	157
Maximum current absorption		A	55	65	73	74	63
Star up current		A	152	179	214	215	203
Star up current with soft starter		A	111	130	153	154	144
Compressors / circuits			2/1				
Expansion vessel volume		dm ³	8	8	18	18	18
Buffer tank volume		dm ³	125	125	350	350	350
Sound power level	(6)(E)	dB(A)	82	82	83	83	83
Transport weight unit with pump and tank		kg	692	713	1004	1020	1025
Operating weight unit with pump and full tank		kg	800	821	1354	1370	1375

(1) Outdoor air temperature 35°C, water temperature 12°C / 7°C (EN14511:2013)

(2) η efficiency values for heating and cooling are respectively calculated by the following formulas: $[\eta = SCOP / 2,5 - F(1) - F(2)]$ e $[\eta = SEER / 2,5 - F(1) - F(2)]$. For further information, please refer to the technical document "ErP 2009/125/EC DIRECTIVE" in the catalogue introducing pages, or to the EN14825:2017 regulation.

(3) Outdoor air temperature dry bulb 7°C / wet bulb 6°C, water temperature 40°C / 45°C (EN14511:2013)

(4) Seasonal energy efficiency class for MEDIUM TEMPERATURE room heating under AVERAGE climatic conditions [EUROPEAN REGULATION No 811/2013]

(5) Seasonal energy efficiency class for LOW TEMPERATURE room heating under AVERAGE climatic conditions [EUROPEAN REGULATION No 811/2013]

(6) Sound power level measured according to ISO 9614

(E) EUROVENT certified data

EVITECH HEAT PUMPS RATED TECHNICAL DATA

Evitech			104	124	154	174	184
Power supply		V-ph-Hz	400 - 3N - 50				
Cooling capacity	(1)(E)	kW	104	124	150	171	181
Total power input	(1)(E)	kW	36,6	45,0	51,2	58,4	62,9
EER	(1)(E)		2,84	2,74	2,93	2,93	2,88
SEER	(2)(E)		4,09	4,09	3,64	3,78	3,79
Water flow	(1)	l/h	17916	21276	25906	29549	31296
Water pressure drop	(1)(E)	kPa	32	22	33	24	27
Available pressure head - LP pumps	(1)	kPa	140	184	166	168	162
Heating capacity	(3)(E)	kW	119	139	173	194	207
Total power input	(3)(E)	kW	34,6	40,8	51,6	56,6	60,4
COP	(3)(E)		3,42	3,41	3,35	3,43	3,42
SCOP	(2)(E)		2,99	3,08	2,89	3,02	3,02
Heating energy efficiency class	(4)		A+				
SCOP	(2)		3,79	3,91	3,49	3,63	3,66
Heating energy efficiency class	(5)		A+	A++	A+	A+	A+
Water flow	(3)	l/h	20289	23834	29636	33295	35408
Water pressure drop	(3)(E)	kPa	42	28	44	30	34
Available pressure head - LP pumps	(3)	kPa	124	174	149	154	146
Maximum current absorption		A	92	112	147	136	125
Star up current		A	189	226	288	277	266
Star up current with soft starter		A	148	177	227	217	207
Compressors / circuits			4/2				
Expansion vessel volume		dm ³	18	18	24	24	24
Buffer tank volume		dm ³	350	350	450	450	450
Sound power level	(6)(E)	dB(A)	84	86	86	86	86
Transport weight unit with pump and tank		kg	2127	2218	1955	1956	1996
Operating weight unit with pump and full tank		kg	2577	2668	2405	2406	2446

(1) Outdoor air temperature 35°C, water temperature 12°C / 7°C (EN14511:2013)

(2) η efficiency values for heating and cooling are respectively calculated by the following formulas: $[\eta = SCOP / 2,5 - F(1) - F(2)]$ e $[\eta = SEER / 2,5 - F(1) - F(2)]$. For further information, please refer to the technical document "ErP 2009/125/EC DIRECTIVE" in the catalogue introducing pages, or to the EN14825:2017 regulation.

(3) Outdoor air temperature dry bulb 7°C / wet bulb 6°C, water temperature 40°C / 45°C (EN14511:2013)

(4) Seasonal energy efficiency class for MEDIUM TEMPERATURE room heating under AVERAGE climatic conditions [EUROPEAN REGULATION No 811/2013]

(5) Seasonal energy efficiency class for LOW TEMPERATURE room heating under AVERAGE climatic conditions [EUROPEAN REGULATION No 811/2013]

(6) Sound power level measured according to ISO 9614

(E) EUROVENT certified data

Air heat pumps with wide working range Evitech

DIMENSIONAL DRAWINGS

EVITECH 52 - 62

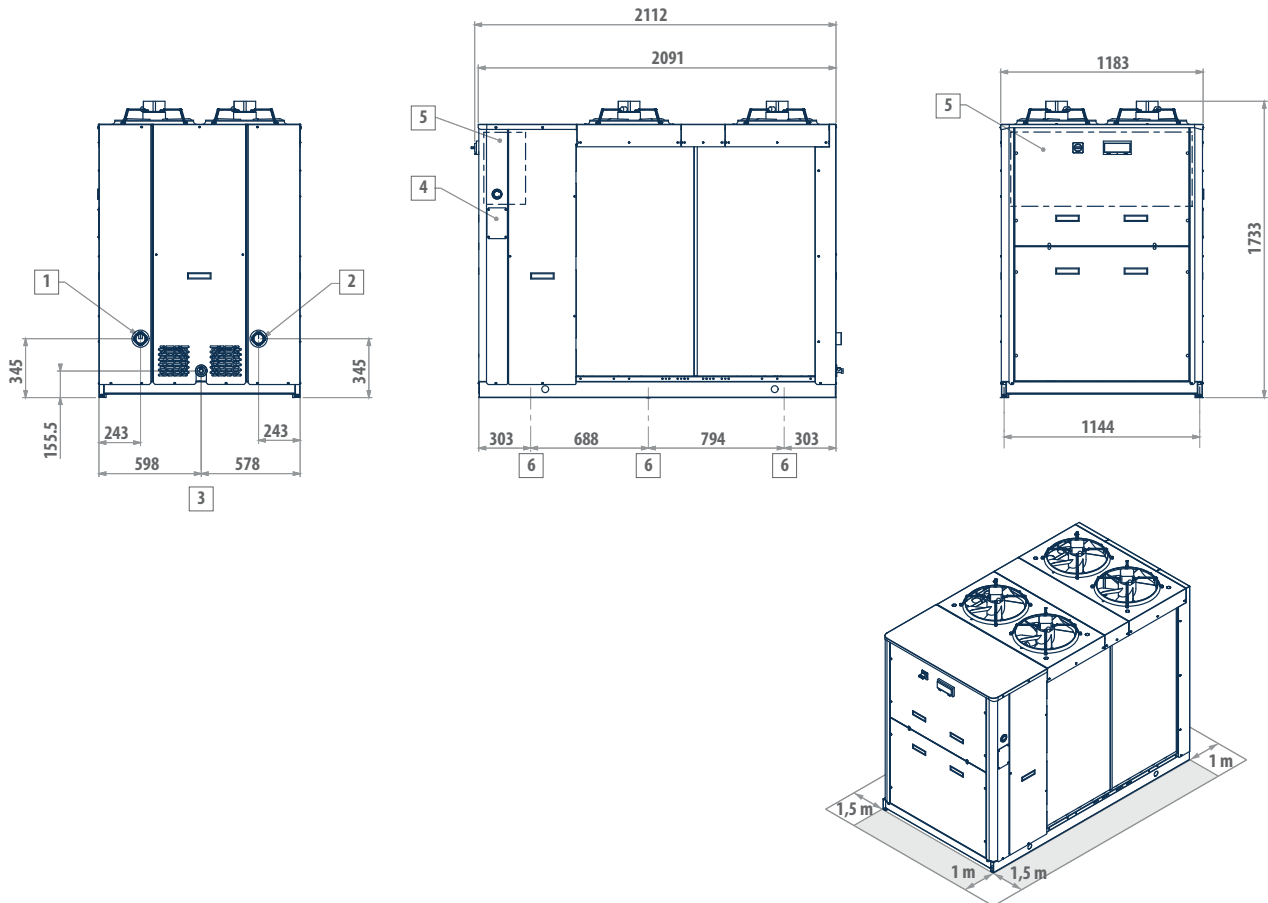

LEGEND

1	Water inlet 2" female
2	Water outlet 2" female
3	Water drainage 1/2" female
4	Power supply
5	Electric control board
6	Fastening points for vibration dampers

DIMENSIONAL DRAWINGS

EVITECH 72 - 82 - 92

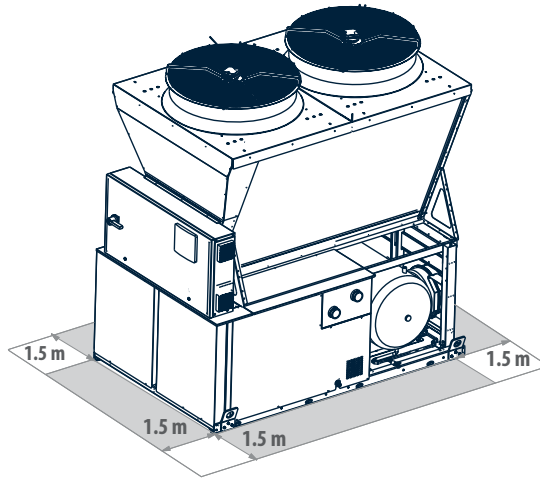
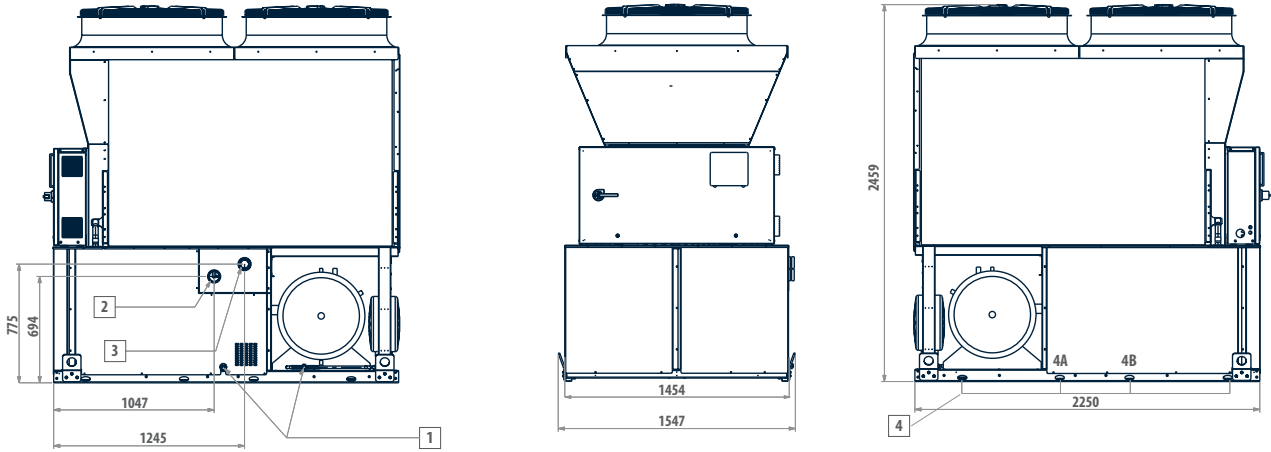

LEGEND

- | | |
|---|-------------------------------|
| 1 | Water drainage 1/2" female |
| 2 | Water inlet Victaulic 2 1/2" |
| 3 | Water outlet Victaulic 2 1/2" |
| 4 | Vibration dumpers |

Air heat pumps with wide working range Evitech

DIMENSIONAL DRAWINGS

EVITECH 104 - 124

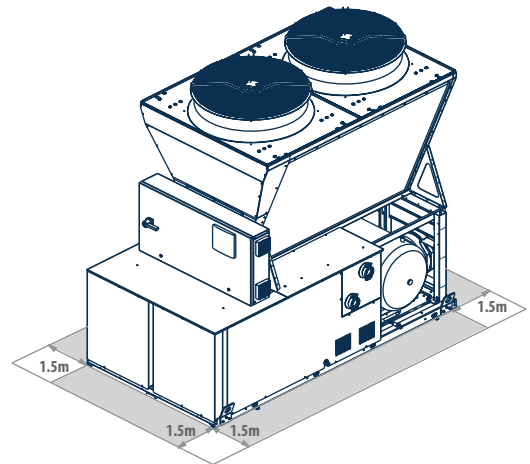
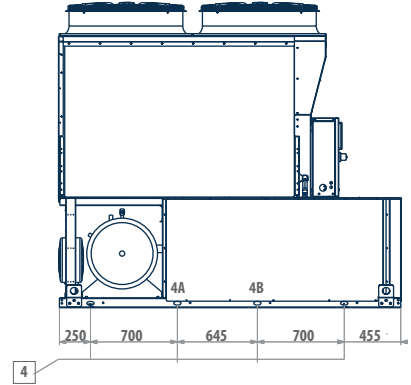
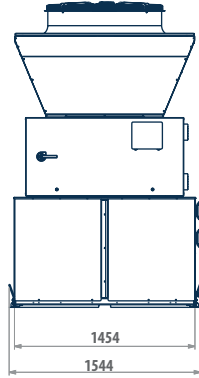
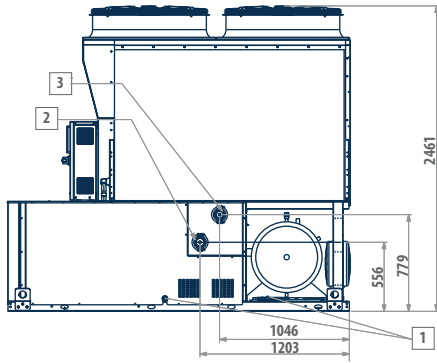

LEGEND

- | | |
|---|-------------------------------|
| 1 | Water drainage 1/2" female |
| 2 | Water inlet Victaulic 2 1/2" |
| 3 | Water outlet Victaulic 2 1/2" |
| 4 | Vibration dumpers |

DIMENSIONAL DRAWINGS

EVITECH 154 - 174 - 184

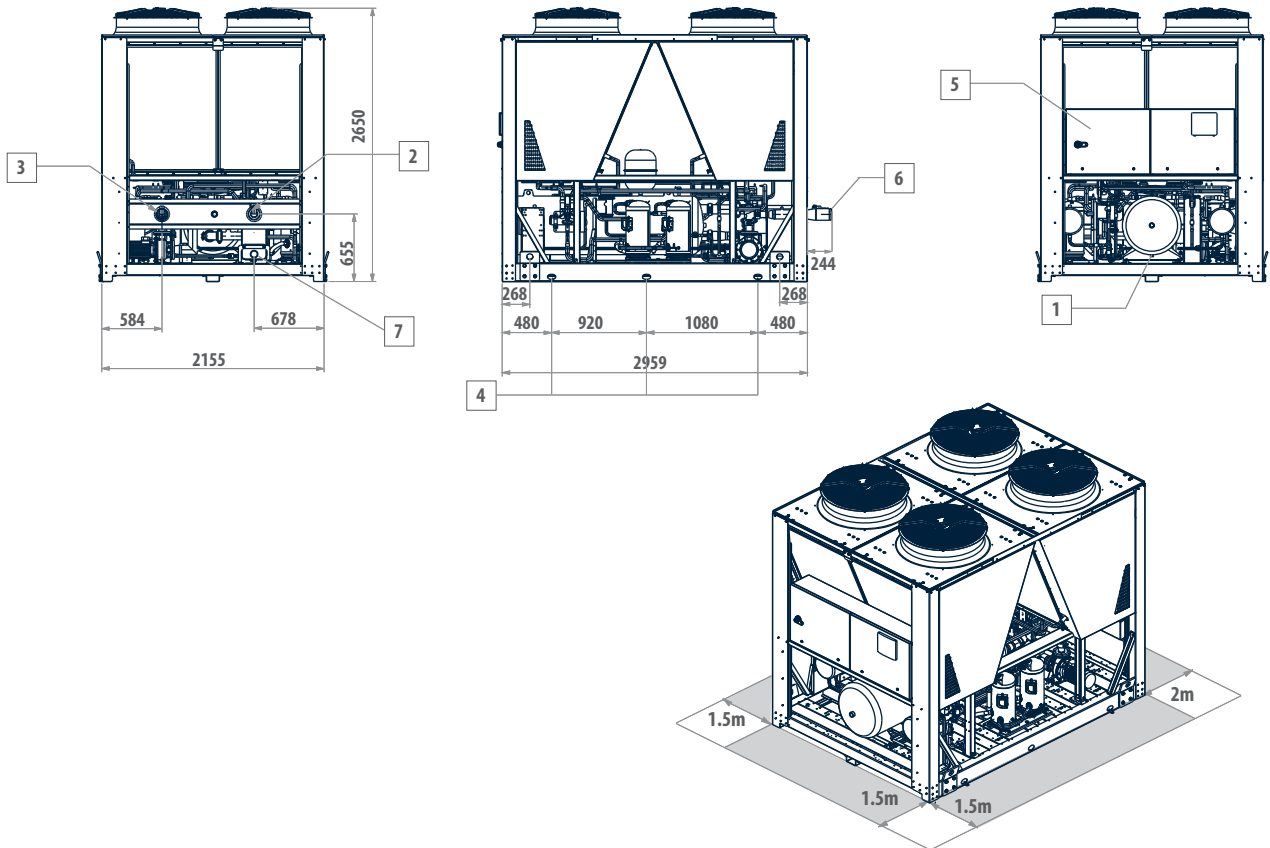

LEGEND

1	Water drainage 1/2" female
2	Water inlet Victaulic 4"
3	Water outlet Victaulic 4"
4	Vibration dumpers
5	Electric control board
6	Victaulic adapter from 4" to 3" to be mounted on-site
7	Water outlet, evaporator only

Outdoor packaged unit

V-IPER 50 - 380 kW

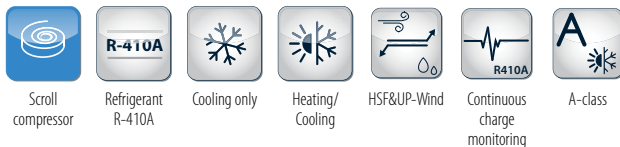

Technology and efficiency in Galletti new solution

V-IPER is Galletti's new high efficiency range, featuring Galletti's most advanced technology in the R410A multiscroll units used in HVAC.

The range consists of 20 air-water models available as chiller and heat pump, with cooling capacities from 50 to 380 kW.

The range's main strongpoint is its high efficiency, not only as time efficiency (Class A Eurovent in chiller and heat pump mode) but especially as seasonal efficiency, aiming to permanently reduce annual energy consumption. In order to increase the efficiency at partial loads, much of the range is comprised of trio solutions (3 compressors on a circuit); furthermore, V-IPER employs components and adjustment logic that make it possible to manage the water-side flow rate modulation.

The range allows high configurability from an acoustic point of view, having a wide range of accessories designed to reduce noise emissions. The advanced control, always present in the whole range, allows a continuous monitoring of the operating parameters, advanced adjustment logics, and connectivity. The modular structure with V configuration condensing coils is designed to optimize air-side heat exchange, to ensure structural strength with a reduced footprint, and to maintain maximum accessibility to the basic components.

PLUS

- » Class A in chiller and heat pump operating mode
- » High efficiency under part load conditions
- » Intelligent modulation of the water flow rate
- » Extended operating range
- » Possibility to configure low-noise versions
- » Counterflow solutions in every operating mode

V-IPER heat pumps and water chillers are designed for heating or cooling the water to be used in air-conditioning systems for residential, commercial or industrial use.

Its high efficiency ensures a considerable reduction in consumption and the ability to operate in various weather conditions.

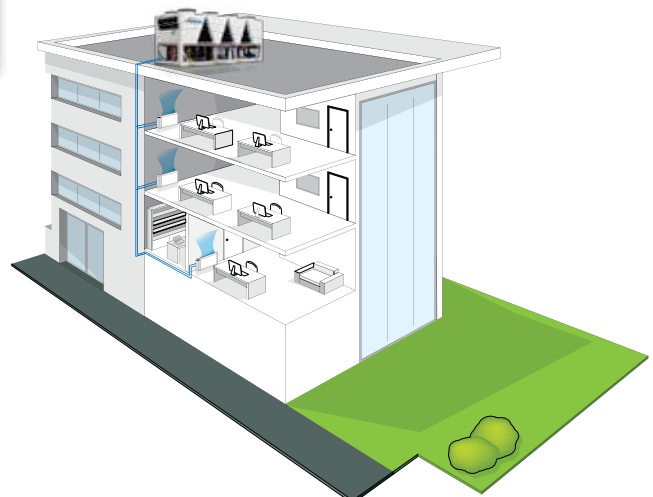

CONFIGURATOR

The models are completely configurable by selecting the version and the options. To the right is shown an example of configuration.

Version	Fields	1	2	3	4	5	6	7	8	9	10	11	12	13
VPR386CS0A		A	1	S	0	C	0	0	0	0	0	0	0	1

To verify the compatibility of the options, use the selection software or the price list.

AVAILABLE VERSIONS

Cooling only versions

- VPR..CS0A 400V-3N-50Hz power supply + circuit breakers
- VPR..CS2A 400V-3-50Hz power supply + transformer + circuit breakers

Versions with reversible heat pump

- VPR..HS0A 400V-3N-50Hz power supply + circuit breakers
- VPR..HS2A 400V-3-50Hz power supply + transformer + circuit breakers

CONFIGURATION OPTIONS

- | | |
|--|--|
| <p>1 Expansion valve</p> <ul style="list-style-type: none"> A Electronic <p>2 Water pump and accessories</p> <ul style="list-style-type: none"> 0 Absent 1 LP pump + expansion vessel 2 LP run and standby double pump + expansion vessel 3 HP pump + expansion vessel 4 HP run and standby double pump + expansion vessel A LP inverter pump + expansion vessel B LP run and standby double inverter pump + expansion vessel C HP inverter pump + expansion vessel D HP run and standby double inverter pump + expansion vessel <p>3 Water buffer tank</p> <ul style="list-style-type: none"> 0 Absent S Present (excludes Hydro Smart Flow) <p>4 Partial heat recovery</p> <ul style="list-style-type: none"> 0 Absent D Desuperheater with water pump free contact <p>5 Air flow modulation</p> <ul style="list-style-type: none"> C Condensation control by phase-cut fans E Condensation control performed by EC fans <p>6 Antifreezing kit</p> <ul style="list-style-type: none"> 0 Absent E Evaporator P Evaporator and water pump S Evaporator, water pump and water buffer tank <p>7 Acoustic insulation and attenuation</p> <ul style="list-style-type: none"> 0 Absent 1 Compressor compartment acoustic insulation 2 Fans noise reduction (AXITOP) | <ul style="list-style-type: none"> 3 Fans noise reduction (AXITOP) + compressor sound blanket + compartment acoustic insulation <p>8 Refrigerant pipework accessories</p> <ul style="list-style-type: none"> 0 Absent M Refrigerant pressure gauges <p>9 Remote control / Serial communication</p> <ul style="list-style-type: none"> 0 Absent 2 RS485 serial board (Carel / Modbus protocol) B BACNET IP / PCOWEB serial board (advanced controller required) F BACNET MS/TP / PCONET card G BACNET IP / PCOWEB + SUPERVISOR SOFTWARE (GWeb) L LON FTT10 serial board (advanced controller required) S Remote simplified user panel T Touch screen control panel X Remote simplified user panel for advanced controller <p>10 Special coils / Protective treatments</p> <ul style="list-style-type: none"> 0 Standard I Hydrophilic M Microchannel outdoor heat exchanger with epoxy coat and anti UV ray protection treatment (standard for chiller) R Copper-copper <p>11 Anti vibration shock mounts</p> <ul style="list-style-type: none"> 0 Absent G Rubber anti vibration shock mounts M Spring anti vibration shock mounts <p>12 Compressors options</p> <ul style="list-style-type: none"> 0 Absent 1 Crankcase compressor heater (CHILLER), outdoor coil trace heater (HP) <p>13 Onboard controller</p> <ul style="list-style-type: none"> 1 Advanced 2 Advanced + touchscreen user panel + USB |
|--|--|

ACCESSORIES

A	Outdoor finned coil heat exchanger protection grille	G	Soft starter
B	Hydro smart flow (water tank not allowed)	H	Power factor capacitors
C	Pair of couplings Victaulic	I	Filter isolation valves kit (solenoid valve and isolation valve)
D	ON/OFF status of the compressors	L	Water pipes additional insulation
E	Remote control for step capacity limit (advanced controller required)	M	0-10 V signal for external user pump control (on-board pump excluded)
F	Configurable digital alarm board (advanced controller required)	N	Compressor tandem/trio isolation valves

EXTENDED OPERATING RANGE

The generous size of the condensing coils combined with various technological solutions allows V-IPER to operate in a wide range of climatic conditions. More specifically:

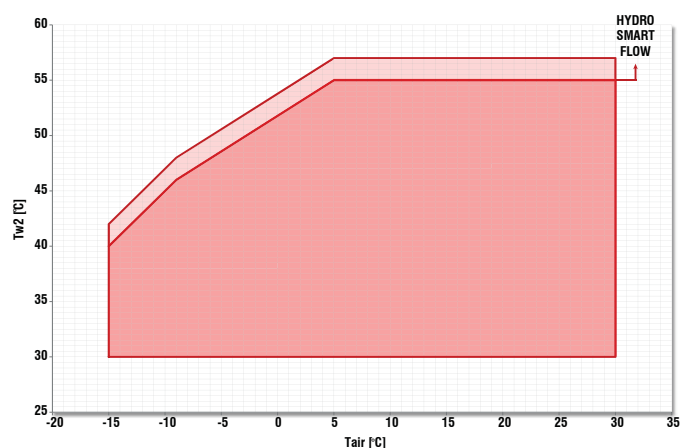
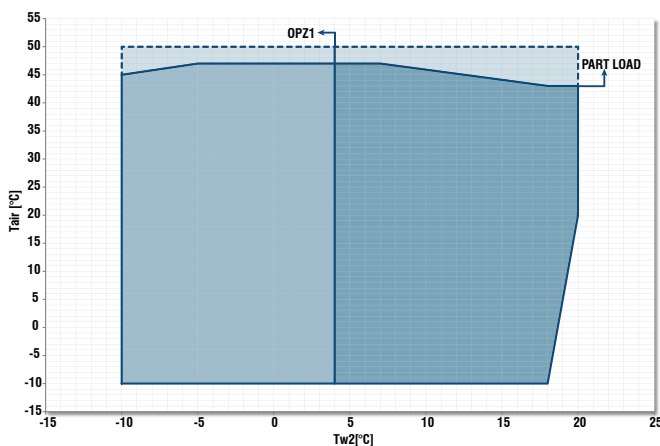

MAIN COMPONENTS

Structure

The range is designed modularly, replicating the optimized structure of V configuration condensing coils and fans. Its design ensures stability, sturdiness even during the most critical phases (such as transportation), and maximum accessibility to components in every V-IPER unit.

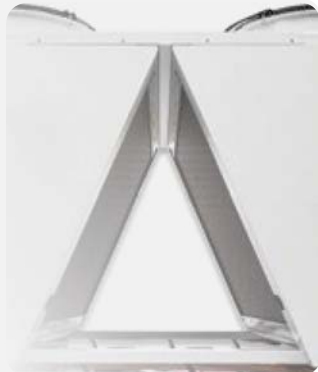

Electronic valve

Supplied as a standard feature, it allows optimization of operation and reduction of power consumption as a result of faster transients.

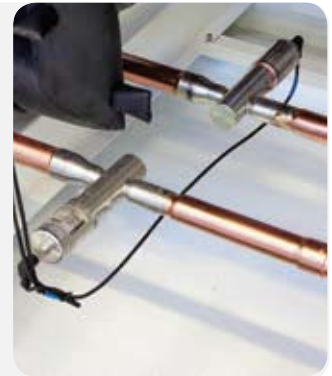

Low noise execution

The units can be supplied in a low-noise version, with noise-canceling headsets, acoustical enclosure for the compressors, and Axitop diffusors on the axial fans. This configuration, combined with the night attenuation function, provides a large reduction in the sound power level.

Hsf - hydro smart flow

Available on request, the HSF kit is placed on the unit's hydronic side and consists of a 4-way valve and a kit. Hydro Smart Flow, which is activated at the time of seasonal changeover, reverses the direction of the water flow over the plates to be consistent with the flow of the refrigerant. In this manner heat exchange always occurs in counterflow, this optimizing the unit's operation in the summer and winter seasons and extending the unit operating range.

Scroll compressors

The range consists of mono- and dual-circuit models in order to offer maximum redundancy. The ability to distribute the load in multiple power steps (up to 6) and the use of trio solutions (3 compressors on a single circuit) ensures maximum efficiency at partial loads and, therefore, greatly increases seasonal efficiency.

Upwind

V-IPER implements a novel technology that allows, when the cycle reverses, to maintain the same direction of flow of the coolant through the condensing coils and to maintain air heat exchange that is always in counterflow. This advanced technology makes it possible to consistently reduce the risk of frost formation on the condensing coils. At the same time, UPWIND ensures optimization of heat exchange during both evaporation and condensing, allowing the Galletti heat pumps to be categorized as Class A (high efficiency) for both heating and cooling.



Microchannel

The entire chiller range features microchannel condensing coils as a standard feature. The large exchange surface, the lack of copper-aluminum interface, and the perfect passage of air makes it possible to achieve the same performance while reducing the refrigerant charge by up to 40%, with obvious benefits from an ecological point of view. The Galletti microchannel condensing coils always have a standard epoxy and UV dual surface treatment that provide 2400 hours of resistance under salt spray test conditions, to offer maximum safety even in aggressive environments.



FUNCTIONS

Variable water flow

The advanced controller allows the management of the variable flow on the primary circuit, thus ensuring an increase in cooling cycle efficiency, reduced pumping costs, and an overall increase in seasonal energy efficiency. The plate heat exchanger has an internal configuration especially designed to operate with modulation of flow rate up to 30% of nominal flow.



Overheating dynamic management

The advanced control, a standard feature of V-IPER, synergistically manages the components in order to achieve maximum efficiency under all load conditions. In particular, when the cooling capacity is reduced, switching off the compressors will modify the superheating setting, thus increasing the efficiency of the cooling cycle.



Economy - low noise function

This feature allows, on the basis of time periods or clean contact, a reduction in the maximum speed of the fans and the compressors that can be activated. This is especially useful during the night phase, when the required power is much lower and the unit can operate in low-impact conditions, thereby reducing the noise level in a sensitive time period.

Charge monitoring

Through continuous monitoring of the cooling cycle's characteristic parameters, V-IPER will detect a possible reduction in the amount of refrigerant and promptly report this situation to prevent more serious problems and protect the main components.

Primary heat pump management

In case of a decoupled circuit, it is possible, via remote sensor, to switch off the primary circuit's pumps, when permitted, due to low thermal load. In this manner a further reduction in pumping costs is achieved.

CDS - Continuously Data Storage

This feature makes it possible to continuously store the characteristic operating parameters of the unit and the system in the control microprocessor. This is achieved through the availability of additional memory, which is provided as a standard feature on the controls of the whole V-IPER range. The stored information can be accessed by means of simple USB memory if the unit is configured with a touch screen interface.



V-IPER C WATER CHILLERS RATED TECHNICAL DATA

V-IPER C			052	062	072	082	092	112	114
Power supply		V-ph-Hz	400 - 3N - 50						
Cooling capacity	(1)(E)	kW	51,4	65,1	73,7	83,7	97,3	109	102
Total power input	(1)(E)	kW	16,0	20,3	22,8	26,2	30,5	34,6	32,4
EER	(1)(E)		3,21	3,21	3,23	3,19	3,19	3,16	3,16
SEER	(2)(E)		4,44	4,50	4,19	4,31	4,35	4,41	4,13
Water flow	(1)	l/h	8875	11249	12737	14458	16777	18824	17654
Water pressure drop	(1)(E)	kPa	37	45	47	41	31	29	31
Available pressure head - LP pumps	(1)	kPa	154	141	189	182	174	141	140
Maximum current absorption		A	40	50	59	68	74	81	79
Star up current		A	138	194	203	212	218	269	178
Star up current with soft starter		A	97	134	142	151	157	190	137
Compressors / circuits			2/1	2/1	2/1	2/1	2/1	2/1	4/2
Expansion vessel volume		dm ³	18	18	18	18	18	18	18
Buffer tank volume		dm ³	250	250	350	350	350	350	350
Sound power level	(3)(E)	dB(A)	80	84	83	83	87	88	87
Transport weight unit with pump and tank		kg	813	823	875	888	968	1048	1866
Operating weight unit with pump and full tank		kg	1163	1173	1225	1238	1318	1398	2316

V-IPER C			133	134	164	173	174	204	213
Power supply		V-ph-Hz	400 - 3N - 50						
Cooling capacity	(1)(E)	kW	125	131	156	166	171	194	203
Total power input	(1)(E)	kW	40,3	42,3	47,7	50,8	52,0	58,8	63,4
EER	(1)(E)		3,10	3,10	3,26	3,26	3,28	3,30	3,21
SEER	(2)(E)		4,51	4,52	4,56	4,30	4,82	4,81	4,31
Water flow	(1)	l/h	21514	22580	26818	28517	29397	33459	35038
Water pressure drop	(1)(E)	kPa	24	24	36	31	24	29	34
Available pressure head - LP pumps	(1)	kPa	138	136	159	162	167	154	145
Maximum current absorption		A	98	101	125	125	136	148	149
Star up current		A	242	245	269	313	280	337	377
Star up current with soft starter		A	181	184	208	235	219	258	281
Compressors / circuits			3/1	4/2	4/2	3/1	4/2	4/2	3/1
Expansion vessel volume		dm ³	18	18	24	24	24	24	24
Buffer tank volume		dm ³	350	350	450	450	450	450	450
Sound power level	(3)(E)	dB(A)	87	87	86	88	87	90	92
Transport weight unit with pump and tank		kg	981	1945	1710	1228	1746	1901	1271
Operating weight unit with pump and full tank		kg	1331	2395	2160	1578	2196	2351	1621

(1) Outdoor air temperature 35°C, water temperature 12°C / 7°C (EN14511:2013)

(2) η efficiency values for heating and cooling are respectively calculated by the following formulas: $[\eta = SCOP / 2,5 - F(1) - F(2)]$ e $[\eta = SEER / 2,5 - F(1) - F(2)]$. For further information, please refer to the technical document "ErP 2009/125/EC DIRECTIVE" in the catalogue introducing pages, or to the EN14825:2017 regulation.

(3) Sound power level measured according to ISO 9614

(E) EUROVENT certified data

V-IPER C WATER CHILLERS RATED TECHNICAL DATA

V-IPER C			226	256	276	306	336	386
Power supply		V-ph-Hz	400 - 3N - 50					
Cooling capacity	(1)(E)	kW	213	250	269	291	329	369
Total power input	(1)(E)	kW	66,4	80,4	84,6	89,2	104	115
EER	(1)(E)		3,20	3,12	3,18	3,26	3,18	3,20
SEER	(2)(E)		4,59	4,78	4,53	4,49	4,58	4,59
Water flow	(1)	l/h	36645	43148	46354	50075	56730	63598
Water pressure drop	(1)(E)	kPa	27	31	32	37	41	45
Available pressure head - LP pumps	(1)	kPa	149	135	176	162	142	161
Maximum current absorption		A	162	195	206	222	247	274
Star up current		A	278	339	395	411	474	502
Star up current with soft starter		A	229	278	316	332	379	407
Compressors / circuits			6/2					
Expansion vessel volume		dm ³	24	24	24	24	24	24
Buffer tank volume		dm ³	450	450	750	750	750	750
Sound power level	(3)(E)	dB(A)	90	90	90	92	93	93
Transport weight unit with pump and tank		kg	1903	1916	2634	2640	2714	3831
Operating weight unit with pump and full tank		kg	2353	2366	3384	3390	3464	4581

(1) Outdoor air temperature 35°C, water temperature 12°C / 7°C (EN14511:2013)

(2) η efficiency values for heating and cooling are respectively calculated by the following formulas: $[\eta = SCOP / 2,5 - F(1) - F(2)]$ e $[\eta = SEER / 2,5 - F(1) - F(2)]$. For further information, please refer to the technical document "ErP 2009/125/EC DIRECTIVE" in the catalogue introducing pages, or to the EN14825:2017 regulation.

(3) Sound power level measured according to ISO 9614

(E) EUROVENT certified data

V-IPER H HEAT PUMPS RATED TECHNICAL DATA

V-IPER H			052	062	072	082	092	112	114
Power supply		V-ph-Hz	400 - 3N - 50						
Cooling capacity	(1)(E)	kW	51,8	65,1	72,3	84,1	96,0	108	103
Total power input	(1)(E)	kW	16,3	20,8	22,9	26,6	30,1	34,4	33,2
EER	(1)(E)		3,18	3,13	3,16	3,16	3,19	3,14	3,11
SEER	(2)(E)		4,31	4,42	4,05	4,23	4,27	4,36	4,46
Water flow	(1)	l/h	8950	11252	12492	14522	16557	18638	17800
Water pressure drop	(1)(E)	kPa	38	45	45	41	30	28	32
Available pressure head - LP pumps	(1)	kPa	153	139	189	182	174	142	140
Heating capacity	(3)(E)	kW	54,4	67,6	78,0	87,9	99,8	111	107
Total power input	(3)(E)	kW	16,5	20,2	23,9	26,8	30,1	33,5	32,8
COP	(3)(E)		3,30	3,35	3,26	3,28	3,32	3,30	3,26
COP with Hydro Smart Flow			+8%						
SCOP	(2)(E)		3,88	3,95	3,60	3,72	3,82	3,87	3,96
Heating energy efficiency class	(4)(E)		A++	A++	A+	A+	A++	A++	A++
Water flow	(3)	l/h	9394	11671	13467	15188	17268	19161	18512
Water pressure drop	(3)(E)	kPa	41	49	52	45	32	30	35
Available pressure head - LP pumps	(3)	kPa	142	124	173	164	155	132	128
Maximum current absorption		A	40	50	59	68	74	81	79
Star up current		A	138	194	203	212	218	269	178
Star up current with soft starter		A	97	134	142	151	157	190	137
Compressors / circuits			2/1	2/1	2/1	2/1	2/1	2/1	4/2
Expansion vessel volume		dm ³	18	18	18	18	18	18	18
Buffer tank volume		dm ³	250	250	350	350	350	350	350
Sound power level	(5)(E)	dB(A)	80	84	83	83	87	88	87
Transport weight unit with pump and tank		kg	938	950	990	1006	1092	1177	1435
Operating weight unit with pump and full tank		kg	1288	1300	1340	1356	1442	1527	1785

V-IPER H			133	134	164	173	174	204	213
Power supply		V-ph-Hz	400 - 3N - 50						
Cooling capacity	(1)(E)	kW	124	130	154	163	168	191	205
Total power input	(1)(E)	kW	40,1	42,0	48,5	50,9	52,5	59,9	64,7
EER	(1)(E)		3,10	3,10	3,18	3,20	3,20	3,19	3,17
SEER	(2)(E)		4,18	4,24	4,05	4,42	4,41	4,64	4,60
Water flow	(1)	l/h	21400	22424	26572	28058	28902	32873	35318
Water pressure drop	(1)(E)	kPa	23	28	35	31	23	28	35
Available pressure head - LP pumps	(1)	kPa	139	132	159	161	168	155	146
Heating capacity	(3)(E)	kW	126	132	161	167	175	200	211
Total power input	(3)(E)	kW	38,2	40,2	49,8	51,8	53,1	59,9	63,8
COP	(3)(E)		3,31	3,27	3,24	3,22	3,30	3,33	3,31
COP with Hydro Smart Flow			+8%						
SCOP	(2)(E)		3,91	3,81	3,71	3,58	3,82	3,86	3,80
Heating energy efficiency class	(4)(E)		A++	A++	A+	A+	A++	A++	A++
Water flow	(3)	l/h	21892	22785	27896	28899	30371	34553	36514
Water pressure drop	(3)(E)	kPa	24	29	38	32	25	31	37
Available pressure head - LP pumps	(3)	kPa	127	118	149	153	159	144	133
Maximum current absorption		A	98	101	125	125	136	148	149
Star up current		A	242	245	269	313	280	337	377
Star up current with soft starter		A	181	184	208	235	219	258	281
Compressors / circuits			3/1	4/2	4/2	3/1	4/2	4/2	3/1
Expansion vessel volume		dm ³	18	18	24	24	24	24	24
Buffer tank volume		dm ³	350	350	450	450	450	450	450
Sound power level	(5)(E)	dB(A)	87	87	86	88	87	90	91
Transport weight unit with pump and tank		kg	1114	1478	1941	2099	1981	2148	2196
Operating weight unit with pump and full tank		kg	1464	1828	2391	2549	2431	2598	2646

V-IPER H HEAT PUMPS RATED TECHNICAL DATA

V-IPER H			226	256	276	306	336	386
Power supply		V-ph-Hz	400 - 3N - 50					
Cooling capacity	(1)(E)	kW	212	249	270	290	327	367
Total power input	(1)(E)	kW	67,8	80,1	85,1	90,7	104	116
EER	(1)(E)		3,13	3,11	3,18	3,19	3,13	3,16
SEER	(2)(E)		4,45	4,66	4,46	4,37	4,45	4,43
Water flow	(1)	l/h	36553	42950	46552	49902	56273	63303
Water pressure drop	(1)(E)	kPa	27	31	33	37	40	45
Available pressure head - LP pumps	(1)	kPa	150	135	175	163	143	160
Heating capacity	(3)(E)	kW	220	253	279	297	337	379
Total power input	(3)(E)	kW	66,3	76,3	84,8	89,4	102	116
COP	(3)(E)		3,32	3,31	3,29	3,33	3,31	3,28
COP with Hydro Smart Flow			+8%					
SCOP	(2)(E)		4,25	4,33	4,02	4,14	4,22	3,94
Heating energy efficiency class	(4)(E)		A++					
Water flow	(3)	l/h	38078	43756	48326	51503	58364	65654
Water pressure drop	(3)(E)	kPa	29	32	35	39	43	48
Available pressure head - LP pumps	(3)	kPa	137	118	162	149	123	145
Maximum current absorption		A	162	195	206	222	247	274
Star up current		A	278	339	395	411	474	502
Star up current with soft starter		A	229	278	316	332	379	407
Compressors / circuits			6/2					
Expansion vessel volume		dm ³	24	24	24	24	24	24
Buffer tank volume		dm ³	450	450	750	750	750	750
Sound power level	(5)(E)	dB(A)	90	90	90	91	93	93
Transport weight unit with pump and tank		kg	2160	2186	2919	2926	3032	4329
Operating weight unit with pump and full tank		kg	2610	2636	3669	3676	3782	5079

(1) Outdoor air temperature 35°C, water temperature 12°C / 7°C (EN14511:2013)

(2) η efficiency values for heating and cooling are respectively calculated by the following formulas: [$\eta = SCOP / 2,5 - F(1) - F(2)$] e [$\eta = SEER / 2,5 - F(1) - F(2)$]. For further information, please refer to the technical document "ErP 2009/125/EC DIRECTIVE" in the catalogue introducing pages, or to the EN14825:2017 regulation.

(3) Outdoor air temperature dry bulb 7°C / wet bulb 6°C, water temperature 40°C / 45°C (EN14511:2013)

(4) Seasonal energy efficiency class for LOW TEMPERATURE room heating under AVERAGE climatic conditions [EUROPEAN REGULATION No 811/2013]

(5) Sound power level measured according to ISO 9614

(E) EUROVENT certified data

DIMENSIONAL DRAWINGS

VPR 52 - 62

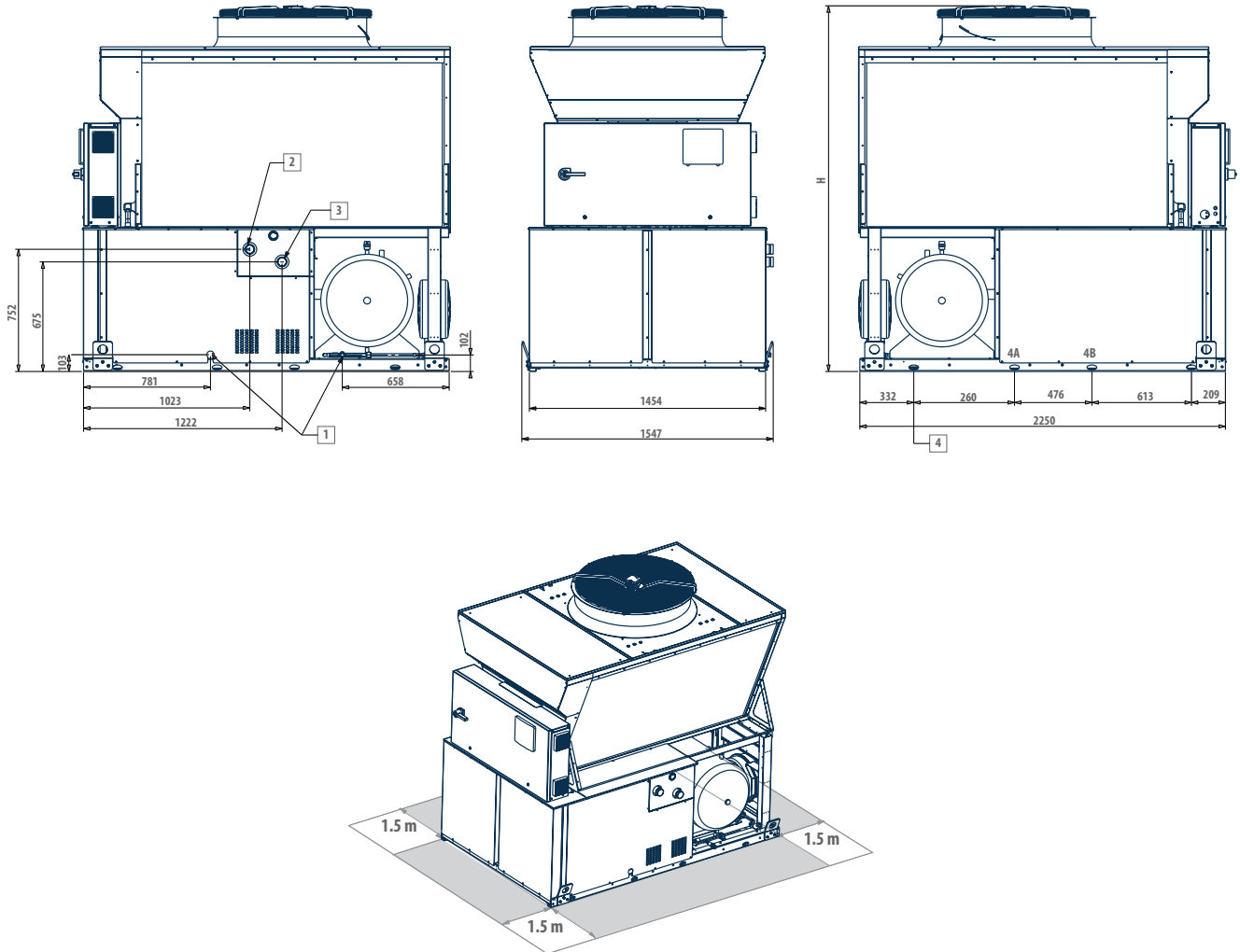

LEGEND

1	Water drainage 1/2" female
2	Water inlet Victaulic 2"
3	Water outlet Victaulic 2"
4	Vibration dumpers
H	Versione C: 2459 - Versione H: 2252

DIMENSIONAL DRAWINGS

VPR 72 - 82 - 92 - 112 - 133

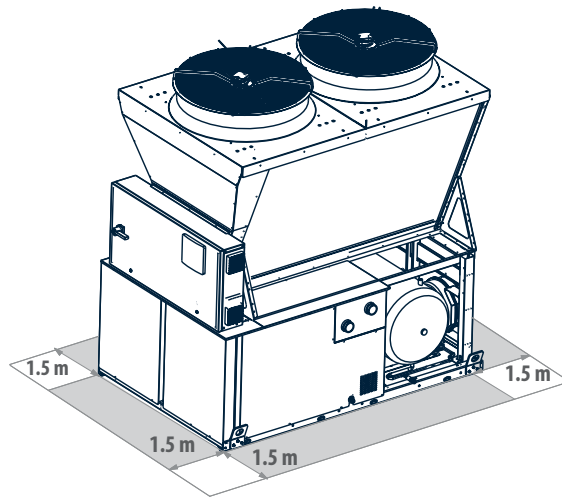
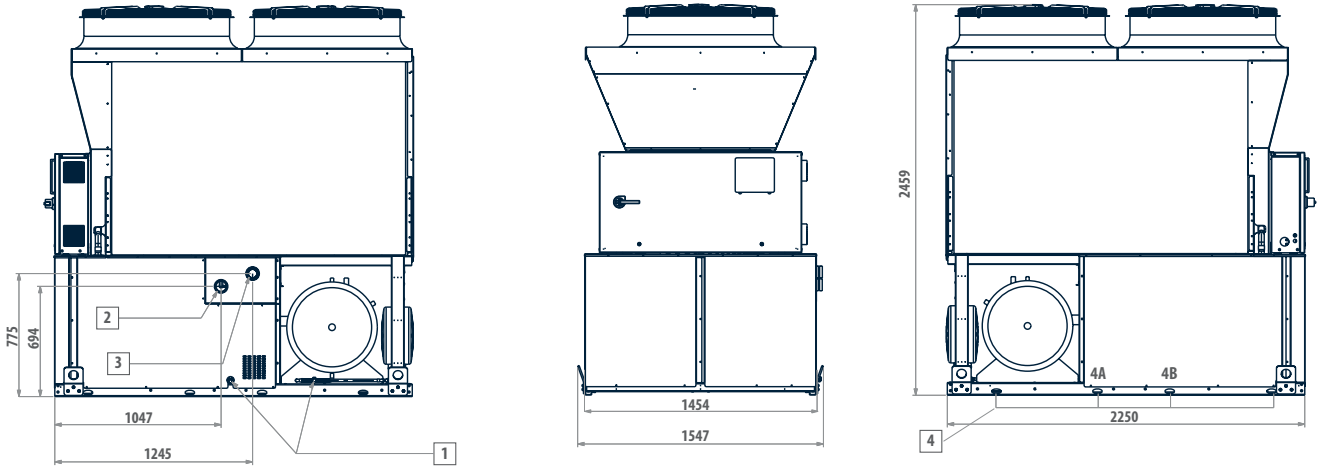

LEGEND

- | | |
|---|-------------------------------|
| 1 | Water drainage 1/2" female |
| 2 | Water inlet Victaulic 2 1/2" |
| 3 | Water outlet Victaulic 2 1/2" |
| 4 | Vibration dumpers |

DIMENSIONAL DRAWINGS

VPR 114 - 134

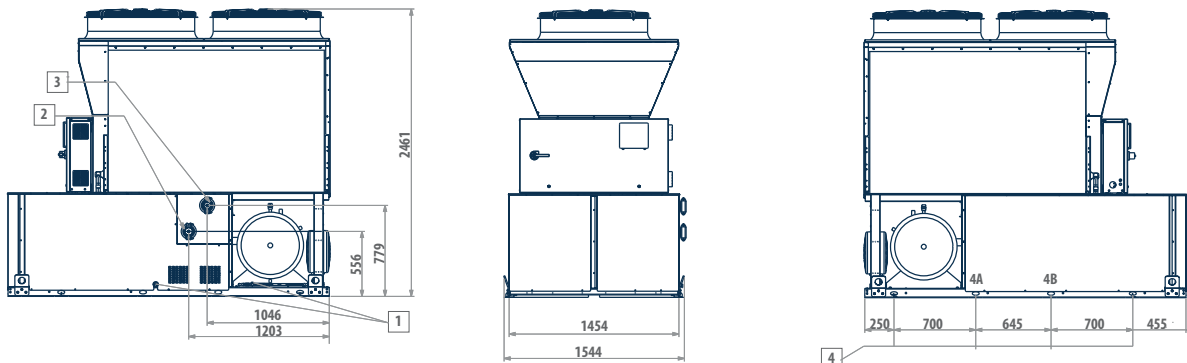

LEGEND

- | | |
|---|-------------------------------|
| 1 | Water drainage 1/2" female |
| 2 | Water inlet Victaulic 2 1/2" |
| 3 | Water outlet Victaulic 2 1/2" |
| 4 | Vibration dumpers |

VPR 173 - 213 - 164 - 174 - 204 - 226 - 256

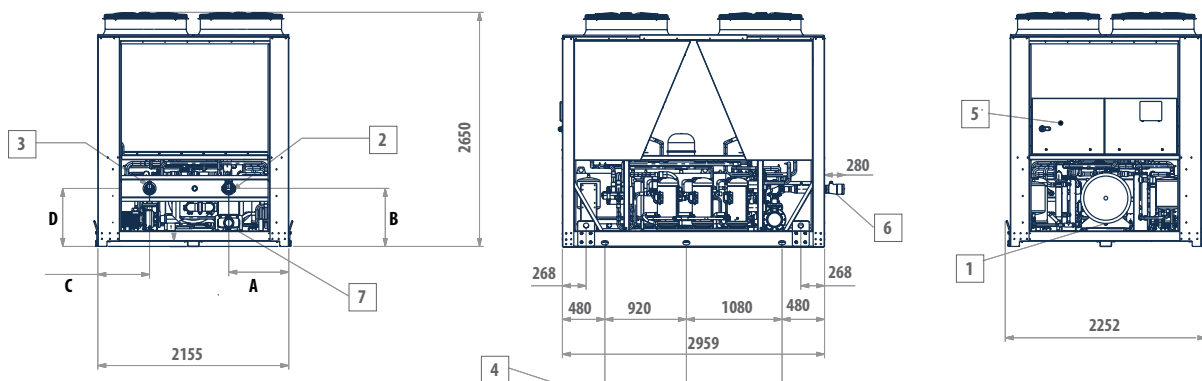

LEGEND

- | | |
|---|---|
| 1 | Water drainage 1/2" female |
| 2 | Water inlet Victaulic 4" |
| 3 | Water outlet Victaulic 4" |
| 4 | Vibration dumpers |
| 5 | Electric control board |
| 6 | Victaulic adapter from 4" to 3" to be mounted on-site |
| 7 | Water outlet, evaporator only |

DIMENSIONAL DRAWINGS

VPR 276 - 306 - 336

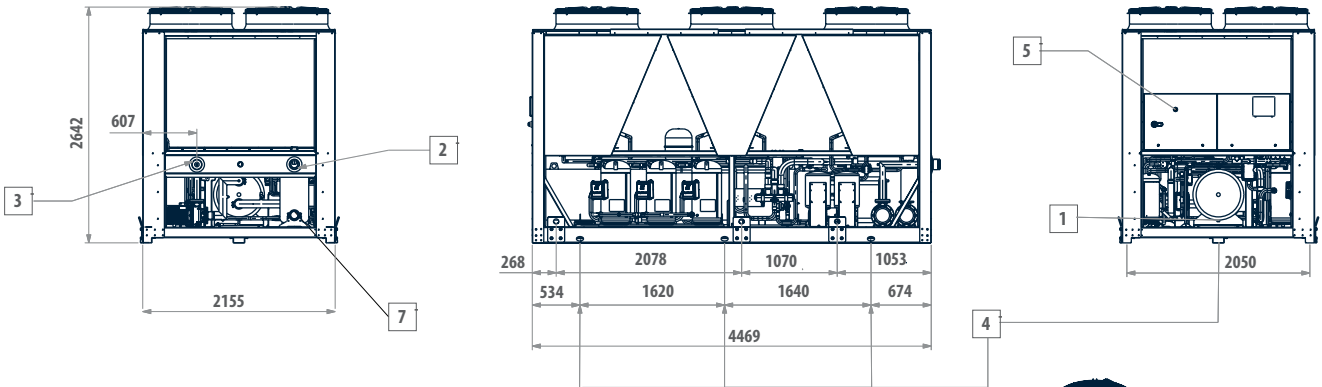

LEGEND

1	Water drainage 1/2" female
2	Water inlet Victaulic 4"
3	Water outlet Victaulic 4"
4	Vibration dumpers
5	Electric control board
6	-
7	Water outlet, evaporator only

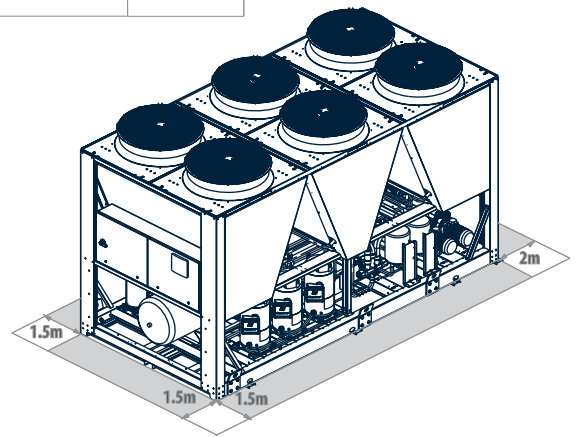

VPR 386

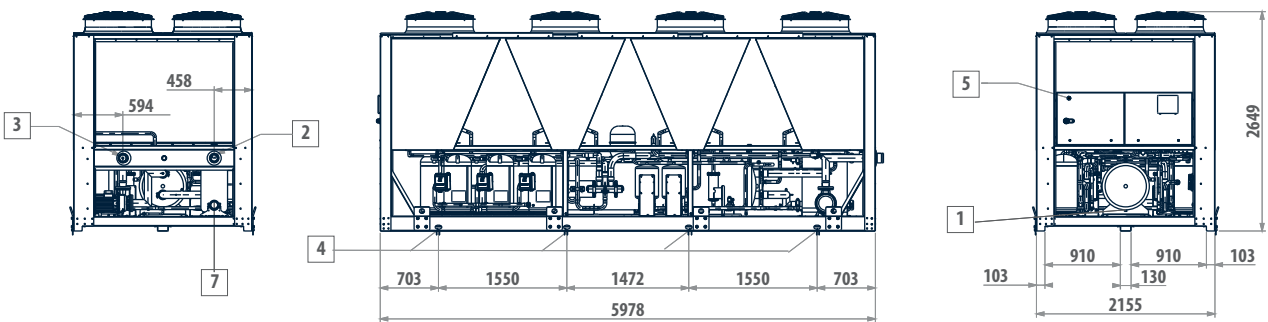

LEGEND

1	Water drainage 1/2" female
2	Water inlet Victaulic 4"
3	Water outlet Victaulic 4"
4	Vibration dumpers
5	Electric control board
6	-
7	Water outlet, evaporator only

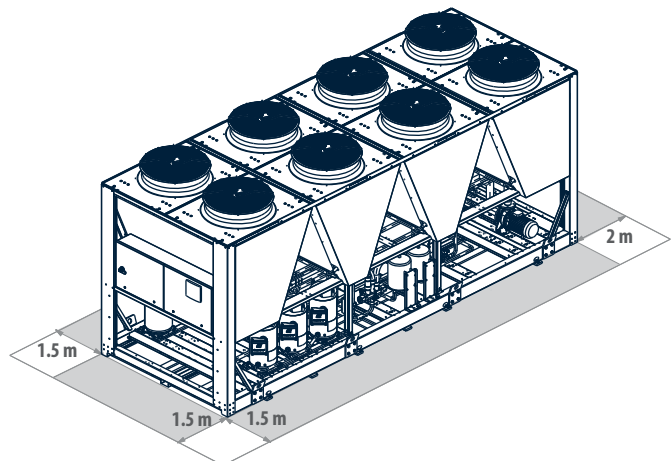

Outdoor packaged unit

SCX 80 - 360 kW



PLUS

- » Completely configurable
- » Incorporable hydraulic kit
- » HyBlade® fans
- » Tandem and trio solutions for high efficiency at partial loads
- » Remote connectivity with the most common protocols
- » Total recovery mode SCX R

The choice to install scroll compressors in a tandem or trio configuration on the same cooling circuit is a move in the right direction in terms of machine efficiency at partial loads, which is the normal operating condition for air conditioning systems.

High configurability and efficiency at partial loads

SCX is the new series of air-cooled heat pumps and chillers designed to meet the requirements of efficiency, configurability, reliability, and ease of maintenance.

The series consists of 22 models with cooling capacities from 80 to 360 kW, in cooling only version or reversible heat pump.

The generously-sized finned pack heat exchanger is designed to optimize both the operation as an evaporator and as a condenser (also in terms of fin type and circuitry).

The solution of a single heat exchanger with delivered power of up to 160 kW was adopted due to the complete accessibility to the internal water and cooling circuit for the periodic inspection and maintenance operations. The solution of a single heat exchanger makes it possible to reduce the space necessary for the installation of the units.

The fan sections, with their exclusive airfoil blades (HyBlade®) are characterized by extraordinary air performance and acoustics and represent the state of the art of the axial fan.

The air diffuser AxiTop® allows to raise the efficiency of the fan with benefits in terms of noise (in combination with the condensation control) and overall efficiency of the unit.

The SCX range adopts innovative solutions in the functioning and layout of the internal components of the hydraulic kit, that is now simplified to reduce connections and minimize the pressure drop on the water side inside the machine.

Every model is completely configurable with a choice of control, hydraulic, acoustic, and heat recovery options that do not result in any change to the dimensions.

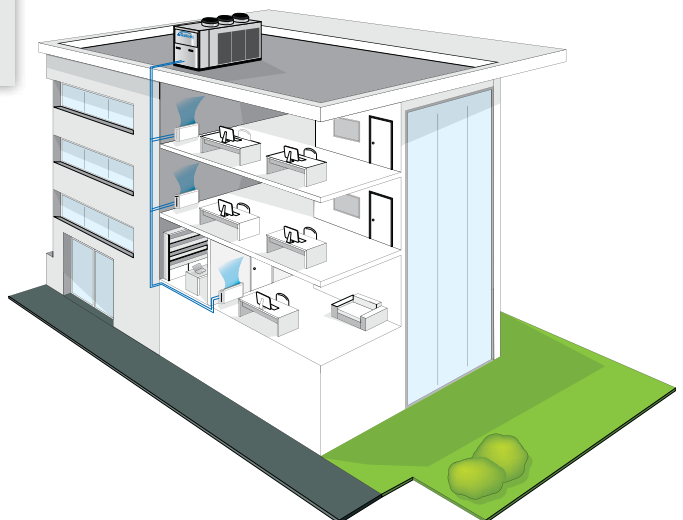

MAIN COMPONENTS

Structure

In galvanized steel and polyester powder coated for outdoor environments. Base frame designed with special reinforcement modules so to eliminate the deformations arising from the stress during transport and handling.

Scroll compressors

Scroll compressors in tandem configuration or trio, with optional acoustical insulation. The levels of efficiency, reliability and noise of such components are the state of the art for the scroll compressor.

Electronic microprocessor control

In standard or advanced version, it enables the complete control of the units. It can be easily accessed through a polycarbonate flap with IP65 protection rating. The electronic control system allows the setpoint to be adjusted automatically according to the outdoor temperature in order to reduce consumption and broaden the working temperature range. The advanced version makes it possible to construct LAN networks for the parallel control of 4 units and the management of BACNET and LON communication protocols, as well as the modulation of the pump assembly, of the Smart Defrost System.

Fan drive assembly

Electric fan with 6-pole external rotor motor directly keyed to the axial fan, with internal thermal protection on the windings, complete with safety grille and dedicated supporting structure. Electric fans with BLDC motor are available on request.



Heat exchanger

In copper pipes (8 mm diameter) and aluminum fins. The particular design criterion of the heat exchangers allows speed up the defrosting phases (for heat pump versions) with obvious benefits in terms of the integrated efficiency of the whole cycle.

CONFIGURATOR

The models are completely configurable by selecting the version and the options. To the right is shown an example of configuration.

Version	Fields	1	2	3	4	5	6	7	8	9	10	11	12	13
SCX162CS0A		0	1	0	S	C	P	1	0	L	0	T	0	2

To verify the compatibility of the options, use the selection software or the price list.

AVAILABLE VERSIONS

Cooling only versions

SCX..CS0A	400V-3N-50Hz power supply
SCX..CS2A	400V-3N-50Hz power supply + circuit breakers
SCX..CS4A	400V-3-50Hz power supply + transformer
SCX..CS5A	400V-3-50Hz power supply + transformer + circuit breakers

Versions with reversible heat pump

SCX..HS0A	400V-3N-50 Hz power supply
SCX..HS2A	400V-3N-50 Hz power supply + circuit breakers
SCX..HS4A	400V-3-50Hz power supply + transformer
SCX..HS5A	400V-3-50Hz power supply + transformer + circuit breakers

CONFIGURATION OPTIONS

- | | |
|--|--|
| <p>1 Expansion valve</p> <ul style="list-style-type: none"> 0 Mechanical A Electronic <p>2 Water pump and accessories</p> <ul style="list-style-type: none"> 0 Absent 1 LP pump + expansion vessel 2 LP run and standby double pump + expansion vessel 3 HP pump + expansion vessel 4 HP run and standby double pump + expansion vessel 5 LP inverter pump + expansion vessel 6 LP run and standby double inverter pump + expansion vessel 7 HP inverter pump + expansion vessel 8 HP run and standby double inverter pump + expansion vessel <p>3 Water buffer tank</p> <ul style="list-style-type: none"> 0 Absent S Selected user side <p>4 Partial heat recovery</p> <ul style="list-style-type: none"> 0 Absent D Desuperheater with water pump free contact <p>5 Air flow modulation</p> <ul style="list-style-type: none"> 0 Absent C Condensation control by phase-cut fans E Condensation control performed by EC fans <p>6 Antifreezing kit</p> <ul style="list-style-type: none"> 0 Absent E Evaporator P Evaporator and water pump S Evaporator, water pump and water buffer tank <p>7 Acoustic insulation and attenuation</p> <ul style="list-style-type: none"> 0 Absent 1 Fans noise reduction (AXITOP) 2 Compressor sound blanket 3 Fans noise reduction (AXITOP) + compressor sound blanket <p>8 Refrigerant pipework accessories</p> | <ul style="list-style-type: none"> 0 Absent M Refrigerant pressure gauges R Filter isolation valves <p>9 Remote control / Serial communication</p> <ul style="list-style-type: none"> 0 Absent 2 RS485 serial board (Carel / Modbus protocol) B BACNET IP / PCOWEB serial board (advanced controller required) F BACNET MS/TP / PCONET card G BACNET IP / PCOWEB + SUPERVISOR SOFTWARE (GWeb) L LON FTT10 serial board (advanced controller required) M Remote simplified user panel for standard controller S Remote simplified user panel X Remote simplified user panel for advanced controller <p>10 Special coils / Protective treatments</p> <ul style="list-style-type: none"> 0 Standard C Cataphoresis I Hydrophilic P Pre-painted fins with epoxy painting R Copper-copper <p>11 Outdoor finned coil heat exchanger protection</p> <ul style="list-style-type: none"> 0 Absent G Outdoor finned coil heat exchanger protection grille T Hail protection cover <p>12 Compressors options</p> <ul style="list-style-type: none"> 0 Absent 1 Power factor capacitors 2 Soft starter 3 Power factor capacitors + soft starter 4 Outdoor coil trace heater 5 Outdoor coil trace heater + soft starter <p>13 Onboard controller</p> <ul style="list-style-type: none"> 1 Basic 2 Advanced 3 Advanced + GSM modem board |
|--|--|

ACCESSORIES

A	Rubber anti vibration shock mounts	F	Remote control for step capacity limit (advanced controller required)
B	Spring anti vibration shock mounts	G	Configurable digital alarm board (advanced controller required)
C	Pair of couplings Victaulic	H	Unit lifting pipes
D	Service kit (advanced controller required)	RYMCL	MyChiller Plus (RS485 serial board required)
E	ON/OFF status of the compressors	RYMCM	MyChiller Base (RS485 serial board required)

Air chillers and heat pumps SCX

SCX C WATER CHILLERS RATED TECHNICAL DATA

SCX C			082	092	102	112	122	142
Power supply		V-ph-Hz	400 - 3N - 50					
Cooling capacity	(1)(E)	kW	78,2	94,0	98,6	111	121	135
Total power input	(1)(E)	kW	27,1	34,5	34,4	37,8	42,8	51,1
EER	(1)(E)		2,89	2,72	2,87	2,93	2,83	2,64
SEER	(2)(E)		3,91	3,87	4,09	4,41	4,38	4,10
Water flow	(1)	l/h	13465	16191	16991	19086	20874	23264
Water pressure drop	(1)(E)	kPa	17	21	26	22	26	32
Available pressure head - LP pumps	(1)	kPa	139	139	130	129	121	166
Maximum current absorption		A	62	69	71	79	88	101
Star up current		A	190	150	237	236	286	329
Star up current with soft starter		A	143	112	176	176	212	246
Compressors / circuits			2 / 1					
Expansion vessel volume		dm ³	12	12	12	12	12	12
Buffer tank volume		dm ³	200	200	340	340	340	340
Sound power level	(3)(E)	dB(A)	80	83	85	86	86	86
Transport weight unit with pump and tank		kg	629	729	1025	1060	1181	1205
Operating weight unit with pump and full tank		kg	815	915	1367	1413	1495	1520

SCX C			162	174	192	194	204	212
Power supply		V-ph-Hz	400 - 3N - 50					
Cooling capacity	(1)(E)	kW	153	173	185	184	194	199
Total power input	(1)(E)	kW	56,4	61,3	62,9	61,0	66,5	69,3
EER	(1)(E)		2,72	2,83	2,94	3,02	2,92	2,88
SEER	(2)(E)		4,41	3,95	4,37	4,47	4,39	4,31
Water flow	(1)	l/h	26419	29902	31843	31811	33453	34350
Water pressure drop	(1)(E)	kPa	25	39	18	42	45	33
Available pressure head - LP pumps	(1)	kPa	163	147	161	138	123	164
Maximum current absorption		A	112	141	130	135	145	141
Star up current		A	329	288	334	290	295	431
Star up current with soft starter		A	245	227	250	229	234	321
Compressors / circuits			2 / 1	4 / 2	2 / 1	4 / 2	4 / 2	2 / 1
Expansion vessel volume		dm ³	12	24	24	24	24	24
Buffer tank volume		dm ³	340	700	700	700	700	700
Sound power level	(3)(E)	dB(A)	86	84	88	86	86	90
Transport weight unit with pump and tank		kg	1247	1074	1347	1212	1254	1398
Operating weight unit with pump and full tank		kg	1556	1724	1924	1865	1929	1997

(1) Outdoor air temperature 35°C, water temperature 12°C / 7°C (EN14511:2013)

(2) η efficiency values for heating and cooling are respectively calculated by the following formulas: $[\eta = SCOP / 2,5 - F(1) - F(2)]$ e $[\eta = SEER / 2,5 - F(1) - F(2)]$. For further information, please refer to the technical document "ErP 2009/125/EC DIRECTIVE" in the catalogue introducing pages, or to the EN14825:2017 regulation.

(3) Sound power level measured according to ISO 9614

(E) EUROVENT certified data

SCX C WATER CHILLERS RATED TECHNICAL DATA

SCX C			214	224	243	244	264	284
Power supply		V-ph-Hz	400 - 3N - 50					
Cooling capacity	(1)(E)	kW	208	222	234	230	264	282
Total power input	(1)(E)	kW	71,2	76,1	82,6	82,1	95,9	103
EER	(1)(E)		2,92	2,91	2,83	2,81	2,76	2,74
SEER	(2)(E)		4,49	4,55	4,59	4,48	3,80	3,81
Water flow	(1)	l/h	35895	38201	40219	39743	45550	48621
Water pressure drop	(1)(E)	kPa	40	38	27	41	28	32
Available pressure head - LP pumps	(1)	kPa	158	147	197	189	183	170
Maximum current absorption		A	152	159	168	166	194	206
Star up current		A	295	301	375	308	401	410
Star up current with soft starter		A	234	241	292	247	317	326
Compressors / circuits			4 / 2	4 / 2	3 / 1	4 / 2	4 / 2	4 / 2
Expansion vessel volume		dm ³	24	24	24	24	24	24
Buffer tank volume		dm ³	700	700	700	700	700	700
Sound power level	(3)(E)	dB(A)	87	88	88	88	88	89
Transport weight unit with pump and tank		kg	1035	1544	3370	1526	2115	2211
Operating weight unit with pump and full tank		kg	1931	2316	2169	2357	2895	2960

SCX C			304	324	344	364
Power supply		V-ph-Hz	400 - 3N - 50			
Cooling capacity	(1)(E)	kW	302	316	341	354
Total power input	(1)(E)	kW	109	115	126	134
EER	(1)(E)		2,78	2,75	2,71	2,63
SEER	(2)(E)		3,82	3,85	3,90	3,83
Water flow	(1)	l/h	52026	54495	58721	60909
Water pressure drop	(1)(E)	kPa	36	30	30	37
Available pressure head - LP pumps	(1)	kPa	160	153	150	130
Maximum current absorption		A	216	228	242	280
Star up current		A	417	427	516	526
Star up current with soft starter		A	334	343	406	415
Compressors / circuits			4 / 2			
Expansion vessel volume		dm ³	24	24	24	24
Buffer tank volume		dm ³	700	700	700	700
Sound power level	(3)(E)	dB(A)	89	89	91	92
Transport weight unit with pump and tank		kg	2428	2449	2465	2482
Operating weight unit with pump and full tank		kg	3056	3077	3089	3110

(1) Outdoor air temperature 35°C, water temperature 12°C / 7°C (EN14511:2013)

(2) η efficiency values for heating and cooling are respectively calculated by the following formulas: $[\eta = SCOP / 2,5 - F(1) - F(2)]$ e $[\eta = SEER / 2,5 - F(1) - F(2)]$. For further information, please refer to the technical document "ErP 2009/125/EC DIRECTIVE" in the catalogue introducing pages, or to the EN14825:2017 regulation.

(3) Sound power level measured according to ISO 9614

(E) EUROVENT certified data

Air chillers and heat pumps SCX

SCX H HEAT PUMPS RATED TECHNICAL DATA

SCX H			082	092	102	112	122	142
Power supply		V-ph-Hz	400 - 3N - 50					
Cooling capacity	(1)(E)	kW	74,7	89,8	95,1	107	117	130
Total power input	(1)(E)	kW	27,3	34,5	34,7	38,6	43,7	51,6
EER	(1)(E)		2,74	2,60	2,74	2,77	2,67	2,52
SEER	(2)(E)		3,69	3,66	3,88	4,11	4,08	3,92
Water flow	(1)	l/h	12874	15482	16386	18407	20123	22384
Water pressure drop	(1)(E)	kPa	17	23	26	22	26	30
Available pressure head - LP pumps	(1)	kPa	136	133	127	126	117	165
Heating capacity	(3)(E)	kW	88,3	106	109	125	137	151
Total power input	(3)(E)	kW	28,2	34,6	35,7	39,0	43,4	49,6
COP	(3)(E)		3,13	3,07	3,05	3,20	3,15	3,05
SCOP	(2)(E)		3,58	3,55	3,58	3,73	3,75	3,53
Heating energy efficiency class	(4)(E)		A+					
Water flow	(3)	l/h	15298	18389	18844	21627	23671	26204
Water pressure drop	(3)(E)	kPa	20	28	29	26	30	37
Available pressure head - LP pumps	(3)	kPa	124	122	116	114	101	142
Maximum current absorption		A	62	69	71	79	88	101
Star up current		A	190	150	237	236	286	329
Star up current with soft starter		A	143	112	176	176	212	246
Compressors / circuits			2 / 1					
Expansion vessel volume		dm ³	12	12	12	12	12	12
Buffer tank volume		dm ³	200	200	340	340	340	340
Sound power level	(5)(E)	dB(A)	80	83	85	86	86	86
Transport weight unit with pump and tank		kg	731	818	1215	1232	1255	1285
Operating weight unit with pump and full tank		kg	913	1022	1530	1547	1570	1600

SCX H			162	174	192	194	204	212
Power supply		V-ph-Hz	400 - 3N - 50					
Cooling capacity	(1)(E)	kW	145	169	178	180	187	192
Total power input	(1)(E)	kW	57,7	61,5	61,4	62,7	66,8	71,2
EER	(1)(E)		2,52	2,74	2,90	2,87	2,81	2,70
SEER	(2)(E)		4,06	3,88	4,31	4,33	4,31	4,03
Water flow	(1)	l/h	25013	29083	30698	31079	32300	33100
Water pressure drop	(1)(E)	kPa	24	37	25	42	37	32
Available pressure head - LP pumps	(1)	kPa	160	150	151	139	132	160
Heating capacity	(3)(E)	kW	170	195	205	207	215	224
Total power input	(3)(E)	kW	54,5	63,5	61,7	65,7	70,7	70,4
COP	(3)(E)		3,12	3,07	3,33	3,15	3,05	3,18
SCOP	(2)(E)		3,86	3,55	3,84	3,73	3,65	3,82
Heating energy efficiency class	(4)(E)		A++	A+	A++	A+	A+	A++
Water flow	(3)	l/h	29494	33742	35574	35842	37257	38748
Water pressure drop	(3)(E)	kPa	29	48	31	53	48	38
Available pressure head - LP pumps	(3)	kPa	137	114	122	97	91	122
Maximum current absorption		A	112	141	130	135	145	141
Star up current		A	329	288	334	290	295	431
Star up current with soft starter		A	245	227	250	229	234	321
Compressors / circuits			2 / 1	4 / 2	2 / 1	4 / 2	4 / 2	2 / 1
Expansion vessel volume		dm ³	12	24	24	24	24	24
Buffer tank volume		dm ³	340	700	700	700	700	700
Sound power level	(5)(E)	dB(A)	86	84	88	86	86	90
Transport weight unit with pump and tank		kg	1335	1174	1634	1584	1639	1696
Operating weight unit with pump and full tank		kg	1650	1824	2042	1980	2048	2120

(1) Outdoor air temperature 35°C, water temperature 12°C / 7°C (EN14511:2013)

(2) η efficiency values for heating and cooling are respectively calculated by the following formulas: $[\eta = SCOP / 2,5 - F(1) - F(2)]$ e $[\eta = SEER / 2,5 - F(1) - F(2)]$. For further information, please refer to the technical document "ErP 2009/125/EC DIRECTIVE" in the catalogue introducing pages, or to the EN14825:2017 regulation.

(3) Outdoor air temperature dry bulb 7°C / wet bulb 6°C, water temperature 40°C / 45°C (EN14511:2013)

(4) Seasonal energy efficiency class for LOW TEMPERATURE room heating under AVERAGE climatic conditions [EUROPEAN REGULATION No 811/2013]

(5) Sound power level measured according to ISO 9614

(E) EUROVENT certified data

SCX H HEAT PUMPS RATED TECHNICAL DATA

SCX H			214	224	243	244	264	284
Power supply		V-ph-Hz	400 - 3N - 50					
Cooling capacity	(1)(E)	kW	195	209	220	222	254	274
Total power input	(1)(E)	kW	72,7	78,4	84,8	82,5	97,0	104
EER	(1)(E)		2,68	2,67	2,59	2,69	2,62	2,64
SEER	(2)(E)		4,20	4,13	4,16	4,24	3,49	3,55
Water flow	(1)	l/h	33556	36030	37886	38220	43819	47133
Water pressure drop	(1)(E)	kPa	40	38	26	42	28	32
Available pressure head - LP pumps	(1)	kPa	157	139	193	182	178	164
Heating capacity	(3)(E)	kW	231	243	258	253	293	318
Total power input	(3)(E)	kW	74,9	78,7	81,8	82,6	99,6	107
COP	(3)(E)		3,08	3,09	3,15	3,07	2,94	2,98
SCOP	(2)(E)		3,74	3,69	3,83	3,70	3,24	3,28
Heating energy efficiency class	(4)(E)		A+	A+	A++	A+	A+	A+
Water flow	(3)	l/h	39967	42076	44676	43844	50740	55048
Water pressure drop	(3)(E)	kPa	54	50	31	54	33	39
Available pressure head - LP pumps	(3)	kPa	108	90	170	146	152	135
Maximum current absorption		A	152	159	168	166	194	206
Star up current		A	295	301	375	308	401	410
Star up current with soft starter		A	234	241	292	247	317	326
Compressors / circuits			4 / 2	4 / 2	3 / 1	4 / 2	4 / 2	4 / 2
Expansion vessel volume		dm ³	24	24	24	24	24	24
Buffer tank volume		dm ³	700	700	700	700	700	700
Sound power level	(5)(E)	dB(A)	87	88	88	88	88	89
Transport weight unit with pump and tank		kg	1400	1844	1842	1850	2421	2507
Operating weight unit with pump and full tank		kg	2050	2459	2302	2502	3073	3142

SCX H			304	324	344	364
Power supply		V-ph-Hz	400 - 3N - 50			
Cooling capacity	(1)(E)	kW	290	302	326	336
Total power input	(1)(E)	kW	110	118	128	134
EER	(1)(E)		2,65	2,57	2,53	2,50
SEER	(2)(E)		3,64	3,30	3,65	3,65
Water flow	(1)	l/h	49996	52054	56077	57911
Water pressure drop	(1)(E)	kPa	36	30	35	37
Available pressure head - LP pumps	(1)	kPa	158	150	143	128
Heating capacity	(3)(E)	kW	339	352	375	390
Total power input	(3)(E)	kW	117	118	122	128
COP	(3)(E)		2,90	2,97	3,06	3,05
SCOP	(2)(E)		3,19	3,29	3,42	3,41
Heating energy efficiency class	(4)(E)		A+			
Water flow	(3)	l/h	58700	61035	64864	67483
Water pressure drop	(3)(E)	kPa	44	41	46	49
Available pressure head - LP pumps	(3)	kPa	120	111	93	75
Maximum current absorption		A	216	228	242	280
Star up current		A	417	427	516	526
Star up current with soft starter		A	334	343	406	415
Compressors / circuits			4 / 2			
Expansion vessel volume		dm ³	24	24	24	24
Buffer tank volume		dm ³	700	700	700	700
Sound power level	(5)(E)	dB(A)	89	89	91	92
Transport weight unit with pump and tank		kg	2522	2538	2543	2565
Operating weight unit with pump and full tank		kg	3161	3180	3187	3217

(1) Outdoor air temperature 35°C, water temperature 12°C / 7°C (EN14511:2013)

(2) η efficiency values for heating and cooling are respectively calculated by the following formulas: $[\eta = SCOP / 2,5 - F(1) - F(2)]$ e $[\eta = SEER / 2,5 - F(1) - F(2)]$. For further information, please refer to the technical document "ErP 2009/125/EC DIRECTIVE" in the catalogue introducing pages, or to the EN14825:2017 regulation.

(3) Outdoor air temperature dry bulb 7°C / wet bulb 6°C, water temperature 40°C / 45°C (EN14511:2013)

(4) Seasonal energy efficiency class for LOW TEMPERATURE room heating under AVERAGE climatic conditions [EUROPEAN REGULATION No 811/2013]

(5) Sound power level measured according to ISO 9614

(E) EUROVENT certified data

Air chillers and heat pumps SCX

TOTAL RECOVERY SCX R C WATER CHILLERS

Series

SCX R is the new series of air source water chillers with total condensation heat recovery.

22 models with cooling capacities from 80 to 360 kW and recovery capacities from 90 to 390 kW complete Galletti's offering of units with condensation heat recovery. The water chillers with total recovery can be used in many applications, from the hotel industry (production of domestic hot water, heating swimming pools, supplying post-heating coils) to industrial sectors requiring the cooling of industrial processes and simultaneous production of hot water.

Electronic microprocessor control

The advanced microprocessor controller manages the recovery of heat which is activated as a function of:

- signal by the temperature probe in the tank on the recovery circuit
- a request for thermal capacity at the same time as a request for cooling capacity
- flow control verifies the proper circulation of water inside the plate of the heat exchanger



Heat recovery exchanger

The total heat recover option is achieved with a brazed plate heat exchanger sized to minimize refrigerant-side head loss. The heat exchanger recovers the condensation heat discharged by the unit (corresponding to the cooling capacity plus the electrical power absorbed by the compressor) for the production of hot water.



CONFIGURATOR

The models are completely configurable by selecting the version and the options. To the right is shown an example of configuration.

Version	Fields	1	2	3	4	5	6	7	8	9	10	11	12	13
SCX162CS0R		0	1	S	1	C	E	1	0	L	0	0	0	2

AVAILABLE VERSIONS

Cooling only versions

SCX..CS0R	400V-3N-50Hz power supply
SCX..CS2R	400V-3N-50Hz power supply + circuit breakers

SCX..CS4R	400V-3-50Hz power supply + transformer
SCX..CSSR	400V-3-50Hz power supply + transformer + circuit breakers

To verify the compatibility of the options, use the selection software or the price list.

CONFIGURATION OPTIONS

- | | |
|--|--|
| <p>1 Expansion valve</p> <p>0 Mechanical</p> <p>A Electronic</p> <p>2 Water pump and accessories</p> <p>0 Absent</p> <p>1 LP pump + expansion vessel</p> <p>2 LP run and standby double pump + expansion vessel</p> <p>3 HP pump + expansion vessel</p> <p>4 HP run and standby double pump + expansion vessel</p> <p>5 LP inverter pump + expansion vessel</p> <p>6 LP run and standby double inverter pump + expansion vessel</p> <p>7 HP inverter pump + expansion vessel</p> <p>8 HP run and standby double inverter pump + expansion vessel</p> <p>3 Water buffer tank</p> <p>0 Absent</p> <p>S Selected</p> <p>4 Recovery pump control</p> <p>1 Dry contact</p> <p>2 0-10 V signal</p> <p>5 Air flow modulation</p> <p>0 Absent</p> <p>C Condensation control by phase-cut fans</p> <p>E Condensation control performed by EC fans</p> <p>6 Antifreezing kit</p> <p>0 Absent</p> <p>E Evaporator</p> <p>P Evaporator and water pump</p> <p>S Evaporator, water pump and water buffer tank</p> <p>7 Acoustic insulation and attenuation</p> <p>0 Absent</p> <p>1 Fans noise reduction (AXITOP)</p> <p>2 Compressor sound blanket</p> <p>3 Fans noise reduction (AXITOP) + compressor sound blanket</p> | <p>8 Refrigerant pipework accessories</p> <p>0 Absent</p> <p>M Refrigerant pressure gauges</p> <p>R Filter isolation valves</p> <p>9 Remote control / Serial communication</p> <p>0 Absent</p> <p>2 RS485 serial board (Carel / Modbus protocol)</p> <p>B BACNET IP / PCOWEB serial board (advanced controller required)</p> <p>F BACNET MS/TP / PCONET card</p> <p>G BACNET IP / PCOWEB + SUPERVISOR SOFTWARE (GWeb)</p> <p>L LON FTT10 serial board (advanced controller required)</p> <p>S Remote simplified user panel</p> <p>X Remote simplified user panel for advanced controller</p> <p>10 Special coils / Protective treatments</p> <p>0 Standard</p> <p>C Cataphoresis</p> <p>I Hydrophilic</p> <p>P Pre-painted fins with epoxy painting</p> <p>R Copper-copper</p> <p>11 Outdoor finned coil heat exchanger protection</p> <p>0 Absent</p> <p>G Outdoor finned coil heat exchanger protection grille</p> <p>T Hail protection cover</p> <p>12 Compressors options</p> <p>0 Absent</p> <p>1 Power factor capacitors</p> <p>2 Soft starter</p> <p>3 Power factor capacitors + soft starter</p> <p>4 Crankcase compressor heater</p> <p>5 Crankcase compressor heater + soft starter</p> <p>13 Onboard controller</p> <p>2 Advanced</p> <p>3 Advanced + GSM modem board</p> |
|--|--|

ACCESSORIES

A	Rubber anti vibration shock mounts	F	Remote control for step capacity limit
B	Spring anti vibration shock mounts	G	Configurable digital alarm board
C	2 pairs of couplings Victaulic	H	Unit lifting pipes
D	Service kit	RYMCL	MyChiller Plus (RS485 serial board required)
E	ON/OFF status of the compressors	RYMCM	MyChiller Base (RS485 serial board required)

RATED TECHNICAL DATA OF TOTAL RECOVERY SCX R C WATER CHILLERS

SCX R C			082R	092R	102R	112R	122R	142R	162R	174R
Power supply		V-ph-Hz	400 - 3N - 50							
Cooling mode operation										
Cooling capacity	(1)	kW	77,4	93,0	97,6	110	120	134	152	192
Total power input	(1)	kW	27,3	34,8	34,7	38,1	43,2	51,5	57,0	67,1
EER	(1)		2,84	2,67	2,81	2,88	2,78	2,59	2,66	2,86
SEER	(2)		3,84	3,80	4,00	4,33	4,30	4,02	4,33	3,87
Water flow	(1)	l/h	13330	16029	16821	18895	20665	23031	26155	33118
Water pressure drop	(1)	kPa	17	21	25	21	25	31	25	44
Available pressure head - LP pumps	(1)	kPa	139	139	130	129	121	166	163	123
Cooling mode operation and DWH in total recovery										
Cooling capacity	(4)	kW	74,9	92,0	93,7	108	119	134	155	185
Heating capacity	(4)	kW	99,2	123	126	143	159	181	206	251
Total power input	(4)	kW	25,6	32,6	34,1	37,8	42,4	49,2	54,2	69,0
COP HRE	(4)		6,80	6,59	6,44	6,64	6,57	6,39	6,67	6,33
Water flow cooling side	(4)	l/h	12892	15842	16142	18517	20507	23079	26674	31981
Water pressure cooling heating side	(4)	kPa	16	20	23	21	25	31	26	41
Available pressure head cold user side - LP pumps	(4)	kPa	142	140	134	131	122	166	160	132
Water flow heating side	(4)	l/h	17182	21274	21805	24828	27574	31247	35723	43399
Water pressure drop heating side	(4)	kPa	26	34	40	35	43	54	44	72
General data										
Maximum current absorption		A	62	69	71	79	88	101	112	145
Star up current		A	190	150	237	236	286	329	329	295
Star up current with soft starter		A	143	112	176	176	212	246	245	234
Compressors / circuits			2 / 1	2 / 1	2 / 1	2 / 1	2 / 1	2 / 1	2 / 1	4 / 2
Expansion vessel volume		dm ³	12	12	12	12	12	12	12	24
Buffer tank volume		dm ³	200	200	340	340	340	340	340	700
Sound power level	(5)	dB(A)	80	83	85	86	86	86	86	86
Transport weight unit with pump and tank		kg	629	729	1025	1060	1181	1205	1247	1074
Operating weight unit with pump and full tank		kg	815	915	1367	1413	1495	1520	1156	1724

(1) Outdoor air temperature 35°C, water temperature 12°C / 7°C (EN14511:2013)

(2) η efficiency values for heating and cooling are respectively calculated by the following formulas: $[\eta = SCOP / 2,5 - F(1) - F(2)]$ e $[\eta = SEER / 2,5 - F(1) - F(2)]$. For further information, please refer to the technical document "ErP 2009/125/EC DIRECTIVE" in the catalogue introducing pages, or to the EN14825:2017 regulation.

(3) Seasonal energy efficiency class for room cooling [EUROPEAN REGULATION No 2281/2016]

(4) Cooling water temperature 12°C / 7°C, recovery water temperature 40°C / 45°C (EN14511:2013)

(5) Sound power level measured according to ISO 9614

Air chillers and heat pumps SCX

RATED TECHNICAL DATA OF TOTAL RECOVERY SCX R C WATER CHILLERS

SCX R C			192R	194R	204R	212R	214R	224R	243R	244R
Power supply		V-ph-Hz	400 - 3N - 50							
Cooling mode operation										
Cooling capacity	(1)	kW	172	197	209	183	219	231	186	232
Total power input	(1)	kW	61,8	69,9	70,6	63,4	76,8	83,3	60,6	81,2
EER	(1)		2,78	2,82	2,96	2,89	2,86	2,78	3,06	2,86
SEER	(2)		4,29	4,35	4,31	4,23	4,41	4,47	4,50	4,40
Water flow	(1)	l/h	29603	34007	36080	31524	37819	39817	32016	40063
Water pressure drop	(1)	kPa	38	32	40	17	37	27	42	41
Available pressure head - LP pumps	(1)	kPa	147	164	154	161	147	197	134	186
Cooling mode operation and DWH in total recovery										
Cooling capacity	(4)	kW	166	193	206	183	219	236	178	234
Heating capacity	(4)	kW	224	259	274	240	291	311	238	310
Total power input	(4)	kW	61,2	69,4	70,9	59,8	75,6	78,9	62,6	79,6
COP HRE	(4)		6,36	6,50	6,76	7,06	6,75	6,92	6,64	6,83
Water flow cooling side	(4)	l/h	28551	33195	35524	31454	37792	40578	30703	40311
Water pressure cooling heating side	(4)	kPa	36	31	39	17	37	28	39	42
Available pressure head cold user side - LP pumps	(4)	kPa	154	170	158	162	147	194	144	185
Water flow heating side	(4)	l/h	38698	44759	47296	41521	50361	53779	41075	53520
Water pressure drop heating side	(4)	kPa	62	52	65	28	62	46	66	69
General data										
Maximum current absorption		A	141	141	152	130	159	168	135	166
Star up current		A	288	431	295	334	301	375	290	308
Star up current with soft starter		A	227	321	234	250	241	292	229	247
Compressors / circuits			4 / 2	2 / 1	4 / 2	2 / 1	4 / 2	3 / 1	4 / 2	4 / 2
Expansion vessel volume		dm ³	24	24	24	24	24	24	24	24
Buffer tank volume		dm ³	700	700	700	700	700	700	700	700
Sound power level	(5)	dB(A)	84	90	87	88	88	88	86	88
Transport weight unit with pump and tank		kg	1347	1212	1254	1398	1035	1544	3370	1526
Operating weight unit with pump and full tank		kg	1924	1865	1929	1997	1931	2316	2169	2357

(1) Outdoor air temperature 35°C, water temperature 12°C / 7°C (EN14511:2013)

(2) η efficiency values for heating and cooling are respectively calculated by the following formulas: $[\eta = SCOP / 2,5 - F(1) - F(2)]$ e $[\eta = SEER / 2,5 - F(1) - F(2)]$. For further information, please refer to the technical document "ErP 2009/125/EC DIRECTIVE" in the catalogue introducing pages, or to the EN14825:2017 regulation.

(3) Seasonal energy efficiency class for room cooling [EUROPEAN REGULATION No 2281/2016]

(4) Cooling water temperature 12°C / 7°C, recovery water temperature 40°C / 45°C (EN14511:2013)

(5) Sound power level measured according to ISO 9614

RATED TECHNICAL DATA OF TOTAL RECOVERY SCX R C WATER CHILLERS

SCX R C			264R	284R	304R	324R	344R	364R
Power supply		V-ph-Hz	400 - 3N - 50					
Cooling mode operation								
Cooling capacity	(1)	kW	267	279	305	313	346	350
Total power input	(1)	kW	94,5	104	107	116	124	136
EER	(1)		2,83	2,69	2,84	2,70	2,79	2,58
SEER	(2)		3,80	3,81	3,80	3,81	3,83	3,81
Water flow	(1)	l/h	46012	48135	52526	53950	59579	60299
Water pressure drop	(1)	kPa	29	31	36	30	31	36
Available pressure head - LP pumps	(1)	kPa	180	170	156	153	145	130
Cooling mode operation and DWH in total recovery								
Cooling capacity	(4)	kW	267	281	301	316	352	359
Heating capacity	(4)	kW	349	372	397	417	460	477
Total power input	(4)	kW	86,3	95,2	101	107	113	124
COP HRE	(4)		7,14	6,86	6,94	6,86	7,19	6,76
Water flow cooling side	(4)	l/h	45962	48471	51901	54365	60685	61902
Water pressure cooling heating side	(4)	kPa	28	32	36	30	32	38
Available pressure head cold user side - LP pumps	(4)	kPa	180	169	159	152	140	123
Water flow heating side	(4)	l/h	60426	64372	68709	72248	79609	82513
Water pressure drop heating side	(4)	kPa	47	53	59	50	52	64
General data								
Maximum current absorption		A	194	206	216	228	242	280
Star up current		A	401	410	417	427	516	526
Star up current with soft starter		A	317	326	334	343	406	415
Compressors / circuits			4 / 2					
Expansion vessel volume		dm ³	24	24	24	24	24	24
Buffer tank volume		dm ³	700	700	700	700	700	700
Sound power level	(5)	dB(A)	88	89	89	89	91	92
Transport weight unit with pump and tank		kg	2115	2211	2428	2449	2465	2482
Operating weight unit with pump and full tank		kg	2895	2960	3056	3077	3089	3110

(1) Outdoor air temperature 35°C, water temperature 12°C / 7°C (EN14511:2013)

(2) η efficiency values for heating and cooling are respectively calculated by the following formulas: $[\eta = SCOP / 2,5 - F(1) - F(2)]$ e $[\eta = SEER / 2,5 - F(1) - F(2)]$. For further information, please refer to the technical document "ErP 2009/125/EC DIRECTIVE" in the catalogue introducing pages, or to the EN14825:2017 regulation.

(3) Seasonal energy efficiency class for room cooling [EUROPEAN REGULATION No 2281/2016]

(4) Cooling water temperature 12°C / 7°C, recovery water temperature 40°C / 45°C (EN14511:2013)

(5) Sound power level measured according to ISO 9614

DIMENSIONAL DRAWINGS

SCX 82 - 92

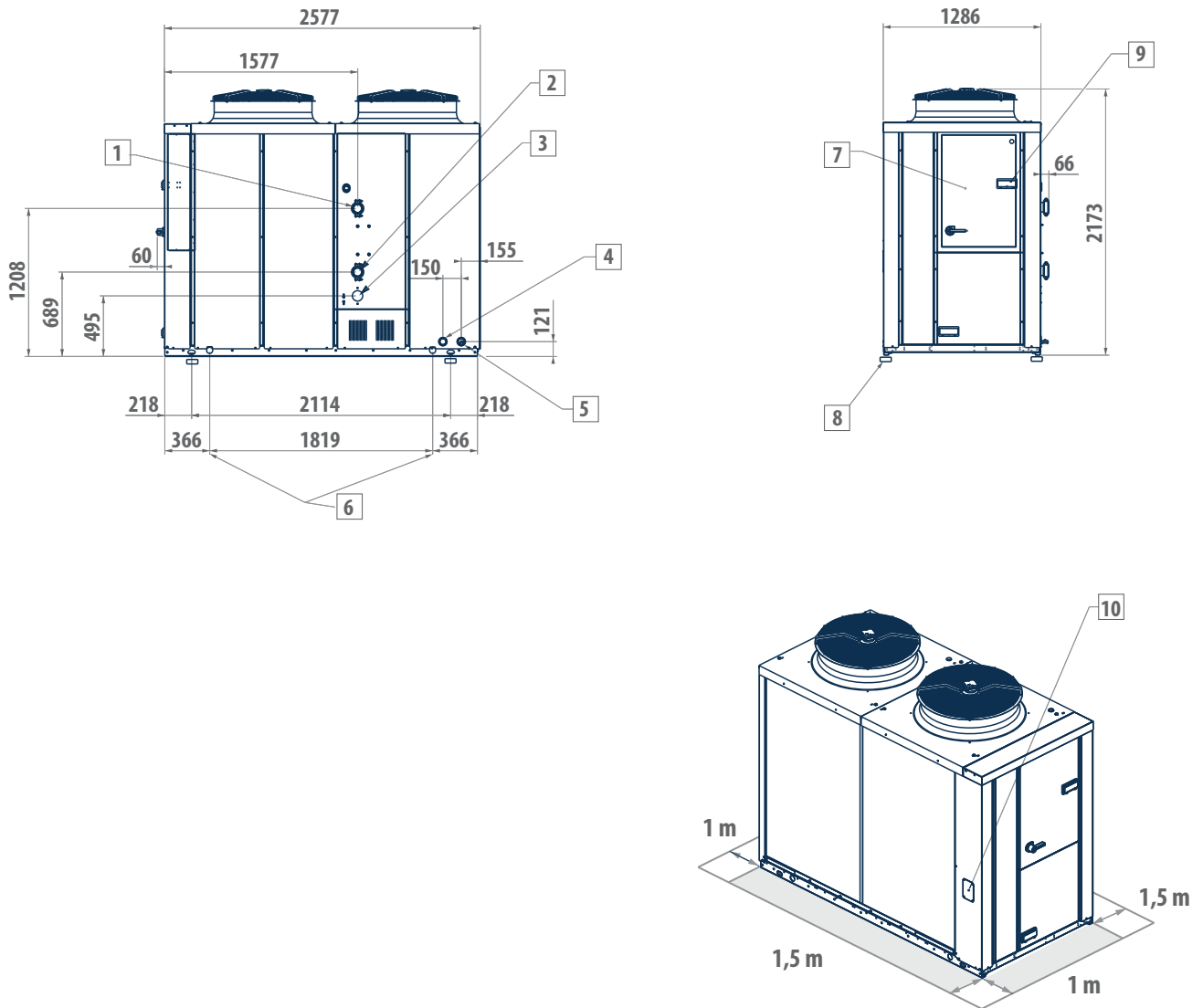

LEGEND

1	Water inlet Victaulic 2"
2	Water outlet, evaporator only Victaulic 2"
3	Water outlet Victaulic 2"
4	Water filling
5	Water drainage
6	Lifting points
7	Electric control board
8	Vibration dampers
9	User interface
10	Power supply input

In order to find total recovery SCX R version dimensional drawings refer to the technical manual

DIMENSIONAL DRAWINGS

SCX 102 - 162

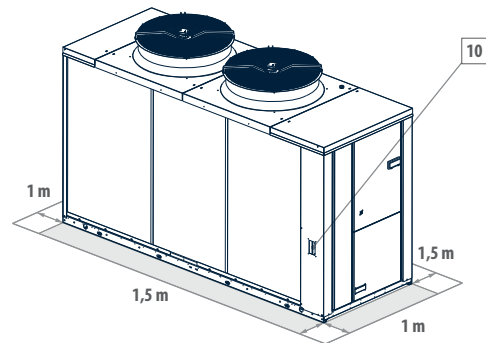
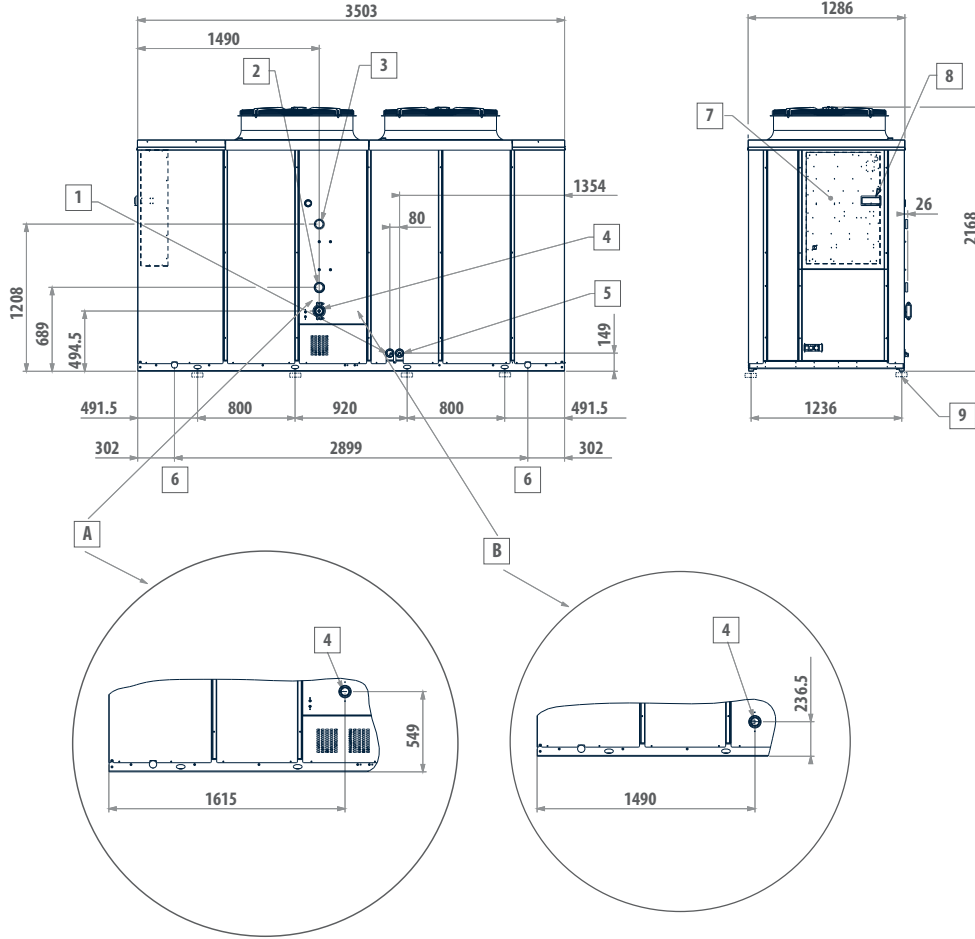

LEGEND

1	Water filling
2	Water outlet, evaporator only Victaulic 2 1/2"
3	Water inlet Victaulic 2 1/2"
4	Water outlet Victaulic 2 1/2"
5	Water drainage
6	Lifting points
7	Electric control board
8	User interface
9	Vibration dampers
10	Power supply input
A	Version with 2 pumps
B	Version with buffer tank only

In order to find total recovery SCX R version dimensional drawings refer to the technical manual

DIMENSIONAL DRAWINGS

SCX 174 - 244

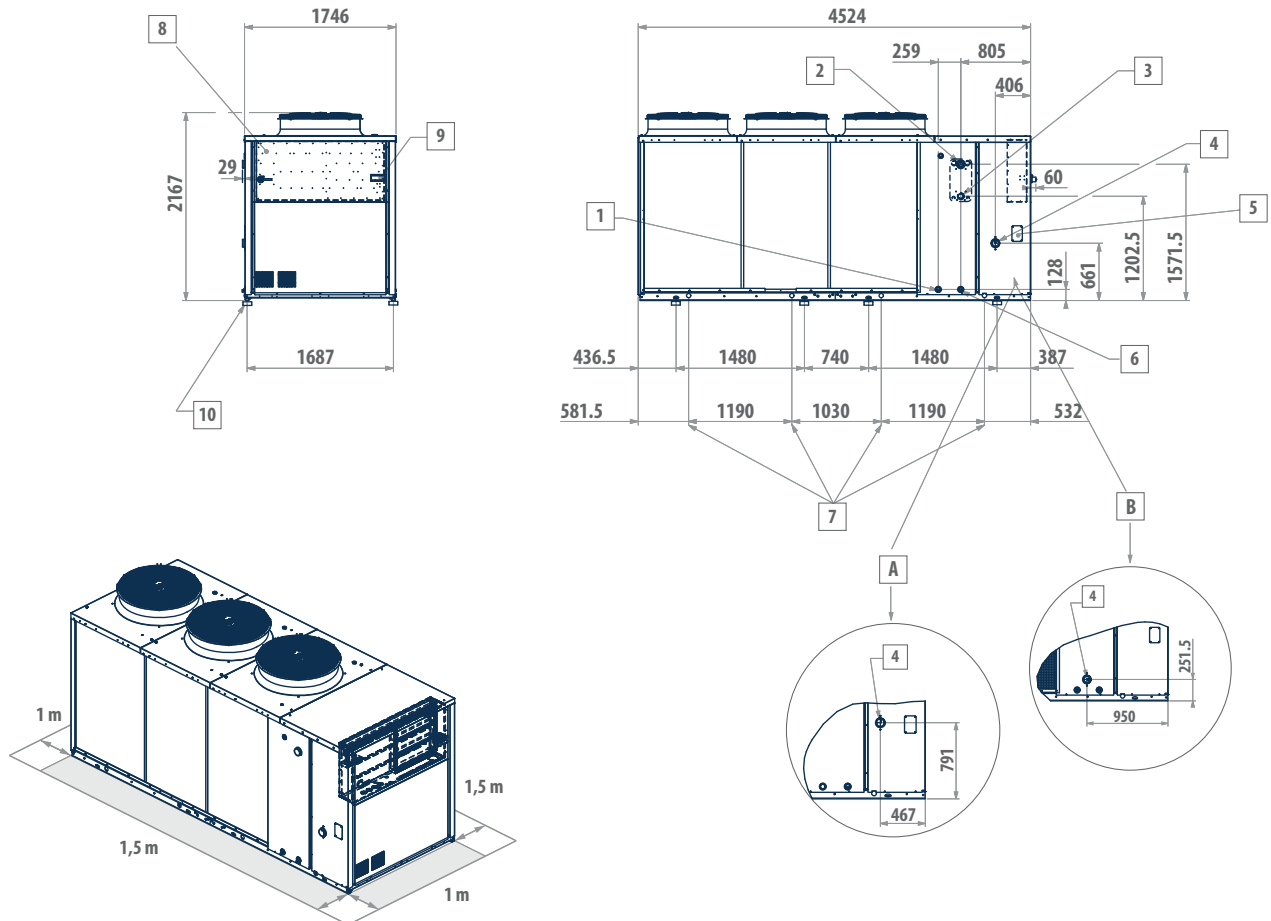

LEGEND

1	Water drainage
2	Water inlet Victaulic 3"
3	Water outlet, evaporator only Victaulic 3"
4	Water outlet Victaulic 3"
5	Power supply input
6	Water filling
7	Lifting points
8	Electric control board
9	User interface
10	Vibration dampers
A	Version with 2 pumps
B	Version with buffer tank only

In order to find total recovery SCX R version dimensional drawings refer to the technical manual

DIMENSIONAL DRAWINGS

SCX 264 - 364

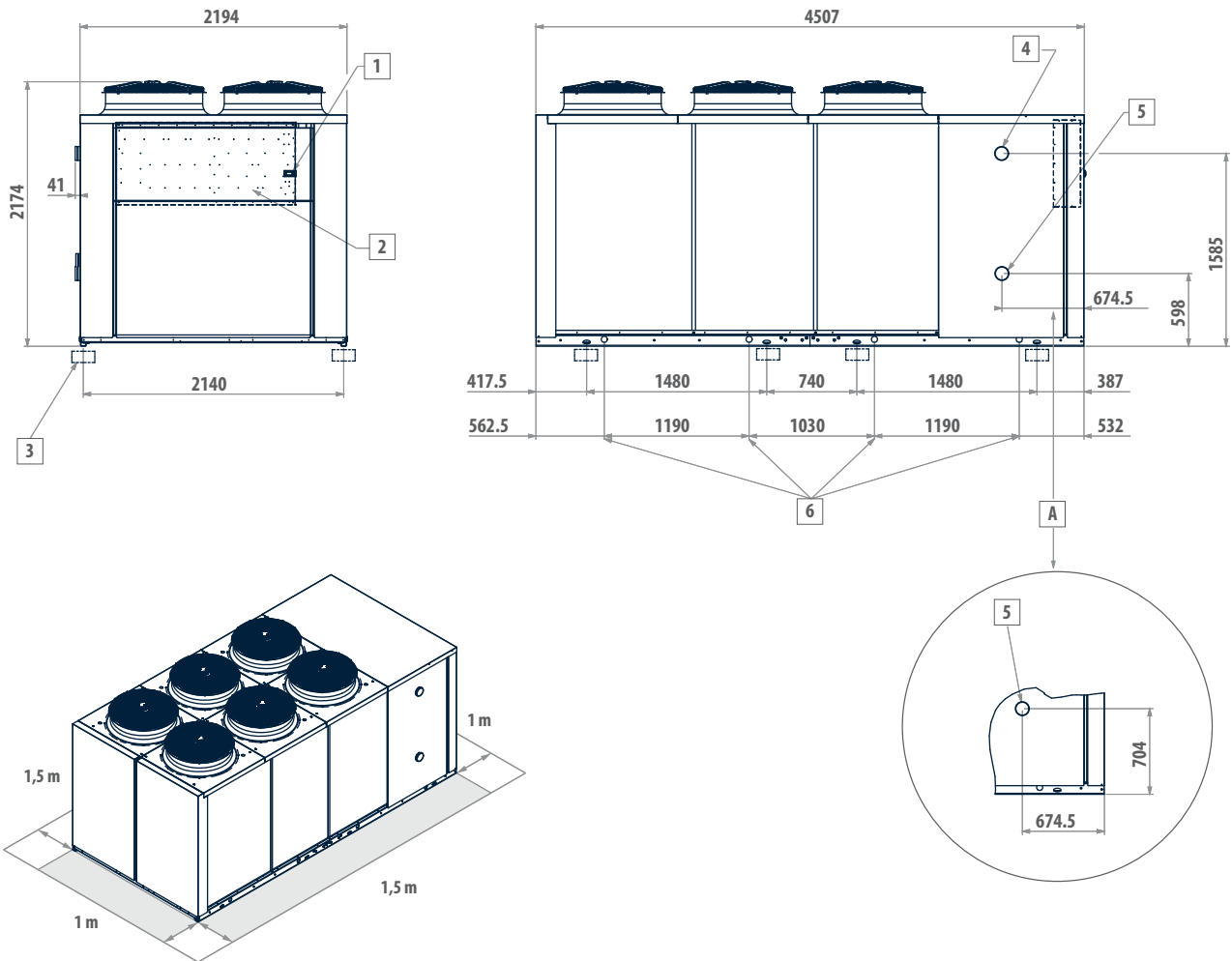

LEGEND

- | | |
|---|---------------------------|
| 1 | User interface |
| 2 | Electric control board |
| 3 | Vibration dampers |
| 4 | Water inlet Victaulic 4" |
| 5 | Water outlet Victaulic 4" |
| 6 | Lifting points |
| A | Version with 2 pumps |

In order to find total recovery SCX R version dimensional drawings refer to the technical manual

Outdoor packaged unit

LCX 55 - 360 kW



LCX: wide range of models and configurability

The main feature of the new LCX design is its extremely wide range: the 16 models that comprise it can be built as chiller, free cooling, or heat pump versions, in 2 different acoustic configurations, and cover a range of powers from 55 to 360 kW.

The possibility of setting up different cooling circuits in units of the same power means being able to personalise efficiency levels under full or part load conditions.

- 1 circuit, 2 compressors. The solution of using two compressors in a single cooling circuit increases efficiency under part load conditions, reaching ESEER/SEER and SCOP values greater than 4.
- 2 circuits / 4 compressors, 4 compressors enable the unit to output power in 4 steps and adapt perfectly to the actual thermal load of the system, while reducing starting currents.

Complete hydronic kits can be incorporated within the units without modifying their size and you have the option of choosing the water circulation pump.

All units, irrespective of type of construction, are equipped with electronic expansion valves to maximise efficiency under part load conditions.

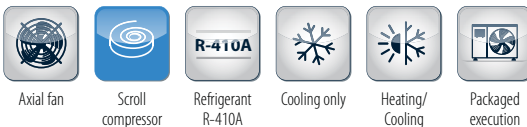

PLUS

- » Super low noise execution available on request
- » Electronic expansion valve
- » Incorporable hydraulic kit
- » Up to 4 compressors
- » 1 or 2 cooling circuits
- » Remote connectivity with the most common protocols
- » Super low noise execution available on request

LCX heat pumps and water chillers are designed for heating or cooling the water to be used in air-conditioning systems for residential, commercial or industrial use.

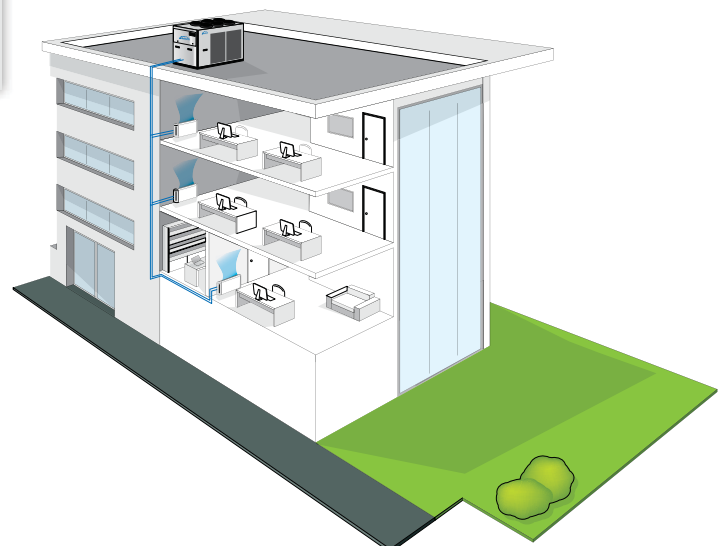

MAIN COMPONENTS

Structure

Made in galvanised steel sheet with a polyester powder coating for outdoors.

The compressor compartment is completely sealed and may be accessed on 3 sides thanks to easy-to-remove panels that greatly simplify maintenance and/or inspection.

Scroll compressors

Scroll compressors are now the best solution in terms of reliability and limiting the sound power emitted. The compressors are supplied complete with motor protection against overheating, overcurrents and excessive outlet gas temperatures.

Heat exchanger

Made of generously sized aluminum fins and copper piping. The special engineering allows defrost cycles to be carried out at maximum speed in the models with heat pump operation, which brings clear benefits in terms of the integrated efficiency of the whole cycle.

Electronic microprocessor control

It completely manages the unit. The electronic control system allows the setpoint to be adjusted automatically according to the outdoor temperature in order to reduce consumption and broaden the working temperature range. With the advanced microprocessor control it is possible to set up LAN networks for controlling up to 4 units in parallel.

Fan drive assembly

Axial fans with airfoil blades made of plastic-aluminum composite, connected to an electric motor with external rotor. The condensation control system continuously and automatically regulates the fan speed. Electric fans with BLDC motor are available on request.



Cooling circuit

It can be made in two different versions with the same power (Efficiency Pack), using mainly:

- R410A scroll compressors
- brazed plate heat exchangers
- finned block condenser
- electronic expansion valve



CONFIGURATOR

The models are completely configurable by selecting the version and the options. To the right is shown an example of configuration.

Version	Fields	1	2	3	4	5	6	7	8	9	10	11	12	13
LCX092HL		0	B	1	S	0	0	S	1	0	0	G	0	V

To verify the compatibility of the options, use the selection software or the price list.

AVAILABLE VERSIONS

Cooling only versions

LCX...CS	Standard execution
LCX...CL	Low noise execution
LCX...CQ	Quiet execution super low noise (on request)

Versions with reversible heat pump

LCX...HS	Standard execution
LCX...HL	Low noise execution
LCX...HQ	Quiet execution super low noise (on request)

CONFIGURATION OPTIONS

- | | |
|--|---|
| <p>1 Power supply</p> <p>0 400 V - 3 N - 50 Hz</p> <p>1 400 V - 3 - 50 Hz</p> <p>2 400 V - 3 N - 50 Hz + magnetic breakers</p> <p>3 400 V - 3 - 50 Hz + magnetic breakers</p> <p>2 Onboard controller and expansion valve</p> <p>0 Basic + electronic expansion valve</p> <p>B Advanced + electronic expansion valve</p> <p>3 User side water pump</p> <p>0 Absent</p> <p>1 LP pump + expansion vessel</p> <p>2 HP pump + expansion vessel</p> <p>3 Double pump LP parallel operation and expansion vessel (advanced controller required)</p> <p>4 Double pump HP parallel operation and expansion vessel (advanced controller required)</p> <p>5 LP run and standby double pump + expansion vessel</p> <p>6 HP run and standby double pump + expansion vessel</p> <p>4 Water buffer tank</p> <p>0 Absent</p> <p>S Selected user side</p> <p>5 Partial heat recovery</p> <p>0 Absent</p> <p>D Desuperheater with water pump free contact</p> <p>6 Air flow modulation</p> <p>0 Absent</p> <p>C Condensation control by phase-cut fans</p> <p>E Condensation control performed by EC fans</p> <p>7 Antifreezing kit</p> <p>0 Absent</p> <p>E Evaporator</p> <p>P Evaporator and water pump</p> <p>S Evaporator, water pump and water buffer tank</p> | <p>8 Remote communication</p> <p>0 Absent</p> <p>1 RS485 serial board (Carel / Modbus protocol)</p> <p>2 LON FTT10 serial board (advanced controller required)</p> <p>3 GSM modem board (advanced controller required)</p> <p>4 BACNET IP / PCOWEB serial board + supervision software Gweb (advanced controller required)</p> <p>5 BACNET IP / PCOWEB serial board + clock board + supervision software Gweb (advanced controller required)</p> <p>9 Special coils / Protective treatments</p> <p>0 Standard</p> <p>B Pre-painted fins with epoxy painting</p> <p>C Cataphoresis</p> <p>R Copper-copper</p> <p>10 Packing</p> <p>0 Standard</p> <p>1 Wooden cage</p> <p>2 Wooden crate</p> <p>11 Anti vibration shock mounts</p> <p>0 Absent</p> <p>G Rubber anti vibration shock mounts</p> <p>M Spring anti vibration shock mounts</p> <p>12 Remote control</p> <p>0 Absent</p> <p>1 Remote simplified user panel</p> <p>2 Remote simplified user panel for standard controller</p> <p>3 Remote simplified user panel for advanced controller</p> <p>13 Unit installation accessories</p> <p>0 Absent</p> <p>V Pair of couplings Victaulic</p> |
|--|---|

ACCESSORIES

A	Power factor capacitors	H	Set point compensation outdoor temperature probe
B	Soft starter	I	Refrigerant pressure gauges
C	Service kit (advanced controller required)	L	Filter isolation valves kit (solenoid valve and isolation valve)
D	Clock board (advanced controller required)	M	Directives reference other than "2014/68/UE - PED"
E	ON/OFF status of the compressors	N	Unit lifting pipes
F	Remote control for step capacity limit (advanced controller required)	P	Outdoor finned coil heat exchanger protection grille
G	Configurable digital alarm board (advanced controller required)	Q	Outdoor finned coil heat exchanger protection filters

LCX CS WATER CHILLERS RATED TECHNICAL DATA

LCX CS			092	102	122	124	142	144	162	
Power supply		V-ph-Hz	400 - 3N - 50							
Cooling capacity	(1)(E)	kW	88,6	102	113	119	144	143	160	
Total power input	(1)(E)	kW	32,2	36,1	40,5	42,1	50,9	50,8	58,9	
EER	(1)(E)		2,75	2,81	2,79	2,83	2,83	2,81	2,71	
SEER	(2)(E)		4,14	4,45	4,05	3,99	4,14	4,20	4,32	
Water flow	(1)	l/h	15284	17517	19447	20517	24815	24665	27525	
Water pressure drop	(1)(E)	kPa	32	32	34	34	36	36	36	
Available pressure head - LP pumps	(1)	kPa	130	127	115	116	176	172	162	
Maximum current absorption		A	91	101	119	120	131	129	144	
Star up current		A	261	269	319	247	330	245	396	
Star up current with soft starter		A	199	207	254	172	265	186	313	
Compressors / circuits			2 / 1	2 / 1	2 / 1	4 / 2	2 / 1	4 / 2	2 / 1	
Expansion vessel volume		dm ³	12	12	12	12	12	12	12	
Buffer tank volume		dm ³	220	220	340	340	340	340	340	
Sound power level	(3)(E)	dB(A)	83	83	83	82	84	82	84	
Transport weight unit with pump and tank		kg	918	918	1241	1301	1286	1321	1316	
Operating weight unit with pump and full tank		kg	1138	1138	1581	1641	1626	1661	1656	

LCX CS			164	174	194	214	244	274	294	
Power supply		V-ph-Hz	400 - 3N - 50							
Cooling capacity	(1)(E)	kW	152	162	183	201	244	263	293	
Total power input	(1)(E)	kW	56,4	58,1	65,6	76,4	95,8	90,5	104	
EER	(1)(E)		2,69	2,78	2,78	2,63	2,55	2,91	2,81	
SEER	(2)(E)		4,19	4,08	4,28	4,31	4,19	4,33	4,37	
Water flow	(1)	l/h	26192	27841	31473	34669	42146	45335	50506	
Water pressure drop	(1)(E)	kPa	36	37	37	38	38	39	40	
Available pressure head - LP pumps	(1)	kPa	162	171	151	163	194	179	166	
Maximum current absorption		A	150	136	155	173	196	224	237	
Star up current		A	266	252	310	330	380	403	468	
Star up current with soft starter		A	214	200	248	268	315	338	385	
Compressors / circuits			4 / 2							
Expansion vessel volume		dm ³	12	24	24	24	24	24	24	
Buffer tank volume		dm ³	340	600	600	600	600	765	765	
Sound power level	(3)(E)	dB(A)	82	85	85	86	86	86	86	
Transport weight unit with pump and tank		kg	1471	1608	1676	1686	1869	2129	2161	
Operating weight unit with pump and full tank		kg	1811	2208	2276	2286	2469	2894	2926	

(1) Outdoor air temperature 35°C, water temperature 12°C / 7°C (EN14511:2013)

(2) η efficiency values for heating and cooling are respectively calculated by the following formulas: $[\eta = SCOP / 2,5 - F(1) - F(2)]$ e $[\eta = SEER / 2,5 - F(1) - F(2)]$. For further information, please refer to the technical document "ErP 2009/125/EC DIRECTIVE" in the catalogue introducing pages, or to the EN14825:2017 regulation.

(3) Sound power level measured according to ISO 9614

(E) EUROVENT certified data

LCX CS WATER CHILLERS RATED TECHNICAL DATA

LCX CS			324	364
Power supply		V-ph-Hz	400 - 3N - 50	
Cooling capacity	(1)(E)	kW	327	354
Total power input	(1)(E)	kW	119	138
EER	(1)(E)		2,76	2,56
SEER	(2)(E)		3,90	4,08
Water flow	(1)	l/h	56411	60931
Water pressure drop	(1)(E)	kPa	41	41
Available pressure head - LP pumps	(1)	kPa	159	137
Maximum current absorption		A	251	300
Star up current		A	476	497
Star up current with soft starter		A	393	440
Compressors / circuits			4 / 2	
Expansion vessel volume		dm ³	24	24
Buffer tank volume		dm ³	765	765
Sound power level	(3)(E)	dB(A)	86	87
Transport weight unit with pump and tank		kg	2196	2196
Operating weight unit with pump and full tank		kg	2961	2961

(1) Outdoor air temperature 35°C, water temperature 12°C / 7°C (EN14511:2013)

(2) η efficiency values for heating and cooling are respectively calculated by the following formulas: $[\eta = SCOP / 2,5 - F(1) - F(2)]$ e $[\eta = SEER / 2,5 - F(1) - F(2)]$. For further information, please refer to the technical document "ErP 2009/125/EC DIRECTIVE" in the catalogue introducing pages, or to the EN14825:2017 regulation.

(3) Sound power level measured according to ISO 9614

(E) EUROVENT certified data

LCX HS HEAT PUMPS RATED TECHNICAL DATA

LCX HS			092	102	122	124	142	144	162	
Power supply		V-ph-Hz	400 - 3N - 50							
Cooling capacity	(1)(E)	kW	87,4	100	111	117	142	141	157	
Total power input	(1)(E)	kW	32,1	36,4	40,4	42,0	50,9	50,7	58,8	
EER	(1)(E)		2,72	2,75	2,75	2,79	2,79	2,78	2,68	
SEER	(2)(E)		4,11	4,38	4,02	3,97	4,10	4,16	4,27	
Water flow	(1)	l/h	15062	17263	19159	20214	24448	24301	27118	
Water pressure drop	(1)(E)	kPa	24	26	27	25	31	31	32	
Available pressure head - LP pumps	(1)	kPa	138	133	122	124	180	176	165	
Heating capacity	(4)(E)	kW	107	120	134	147	166	168	184	
Total power input	(4)(E)	kW	30,0	34,2	38,1	41,7	47,7	47,3	53,1	
COP	(4)(E)		3,56	3,52	3,50	3,52	3,49	3,56	3,47	
SCOP	(2)(E)		4,22	4,30	4,18	4,11	4,13	4,10	4,14	
Heating energy efficiency class	(5)(E)		A++							
Water flow	(4)	l/h	18452	20809	23097	25393	28799	29100	31918	
Water pressure drop	(4)(E)	kPa	36	37	39	39	43	44	45	
Available pressure head - LP pumps	(4)	kPa	123	115	105	106	158	150	133	
Maximum current absorption		A	91	101	119	120	131	129	144	
Star up current		A	261	269	319	247	330	245	396	
Star up current with soft starter		A	199	207	254	172	265	186	313	
Compressors / circuits			2 / 1	2 / 1	2 / 1	4 / 2	2 / 1	4 / 2	2 / 1	
Expansion vessel volume		dm ³	12	12	12	12	12	12	12	
Buffer tank volume		dm ³	220	220	340	340	340	340	340	
Sound power level	(6)(E)	dB(A)	83	83	83	82	84	82	84	
Transport weight unit with pump and tank		kg	918	918	1241	1301	1286	1321	1316	
Operating weight unit with pump and full tank		kg	1138	1138	1581	1641	1626	1661	1656	

LCX HS			164	174	194	214	244	274	294	
Power supply		V-ph-Hz	400 - 3N - 50							
Cooling capacity	(1)(E)	kW	150	159	180	198	241	259	289	
Total power input	(1)(E)	kW	56,3	58,1	65,6	76,3	95,7	90,4	104	
EER	(1)(E)		2,66	2,74	2,74	2,60	2,52	2,87	2,77	
SEER	(2)(E)		4,15	3,45	3,64	3,67	3,55	3,69	3,73	
Water flow	(1)	l/h	25805	27429	31007	34156	41524	44665	49760	
Water pressure drop	(1)(E)	kPa	32	33	34	35	35	35	35	
Available pressure head - LP pumps	(1)	kPa	166	173	153	165	196	182	170	
Heating capacity	(4)(E)	kW	179	189	214	233	282	309	343	
Total power input	(4)(E)	kW	50,7	56,9	64,6	71,0	85,6	88,7	99,5	
COP	(4)(E)		3,53	3,32	3,31	3,28	3,29	3,48	3,44	
SCOP	(2)(E)		4,06	3,57	3,64	3,64	3,66	3,71	3,74	
Heating energy efficiency class	(5)(E)		A++	A+	A+	A+	A+	A+	A+	
Water flow	(4)	l/h	30961	32718	37042	40356	48773	53510	59333	
Water pressure drop	(4)(E)	kPa	45	47	48	49	48	50	50	
Available pressure head - LP pumps	(4)	kPa	136	148	118	124	168	152	136	
Maximum current absorption		A	150	136	155	173	196	224	237	
Star up current		A	266	252	310	330	380	403	468	
Star up current with soft starter		A	214	200	248	268	315	338	385	
Compressors / circuits			4 / 2							
Expansion vessel volume		dm ³	12	24	24	24	24	24	24	
Buffer tank volume		dm ³	340	600	600	600	600	765	765	
Sound power level	(6)(E)	dB(A)	82	85	85	86	86	86	86	
Transport weight unit with pump and tank		kg	1471	1608	1676	1686	1869	2129	2161	
Operating weight unit with pump and full tank		kg	1811	2208	2276	2286	2469	2894	2926	

LCX HS HEAT PUMPS RATED TECHNICAL DATA

LCX HS			324	364
Power supply		V-ph-Hz	400 - 3N - 50	
Cooling capacity	(1)(E)	kW	323	348
Total power input	(1)(E)	kW	119	138
EER	(1)(E)		2,72	2,53
SEER	(2)(E)		3,86	4,04
Water flow	(1)	l/h	55581	60030
Water pressure drop	(1)(E)	kPa	37	35
Available pressure head - LP pumps	(1)	kPa	161	142
Heating capacity	(4)(E)	kW	374	409
Total power input	(4)(E)	kW	110	128
COP	(4)(E)		3,39	3,19
SCOP	(2)(E)		3,75	3,69
Heating energy efficiency class	(5)(E)		A+	
Water flow	(4)	l/h	64799	70746
Water pressure drop	(4)(E)	kPa	50	49
Available pressure head - LP pumps	(4)	kPa	120	89
Maximum current absorption		A	251	300
Star up current		A	476	497
Star up current with soft starter		A	393	440
Compressors / circuits			4 / 2	
Expansion vessel volume		dm ³	24	24
Buffer tank volume		dm ³	765	765
Sound power level	(6)(E)	dB(A)	86	87
Transport weight unit with pump and tank		kg	2196	2196
Operating weight unit with pump and full tank		kg	2961	2961

(1) Outdoor air temperature 35°C, water temperature 12°C / 7°C (EN14511:2013)

(2) η efficiency values for heating and cooling are respectively calculated by the following formulas: $[\eta = SCOP / 2,5 - F(1) - F(2)]$ e $[\eta = SEER / 2,5 - F(1) - F(2)]$. For further information, please refer to the technical document "ErP 2009/125/EC DIRECTIVE" in the catalogue introducing pages, or to the EN14825:2017 regulation.

(3) Seasonal energy efficiency class for room cooling [EUROPEAN REGULATION No 2281/2016]

(4) Outdoor air temperature dry bulb 7°C / wet bulb 6°C, water temperature 40°C / 45°C (EN14511:2013)

(5) Seasonal energy efficiency class for LOW TEMPERATURE room heating under AVERAGE climatic conditions [EUROPEAN REGULATION No 811/2013]

(6) Sound power level measured according to ISO 9614

(E) EUROVENT certified data

LCX CL WATER CHILLERS RATED TECHNICAL DATA

LCX CL			062	072	082	092	094	102	104
Power supply		V-ph-Hz	400 - 3N - 50						
Cooling capacity	(1)(E)	kW	58,2	66,6	78,5	88,6	90,3	102	104
Total power input	(1)(E)	kW	20,3	22,9	26,6	31,1	31,5	35,2	36,0
EER	(1)(E)		2,87	2,91	2,95	2,85	2,87	2,89	2,90
SEER	(2)(E)		4,13	4,39	4,64	4,40	4,15	4,67	4,46
Water flow	(1)	l/h	10035	11482	13549	15283	15574	17539	18027
Water pressure drop	(1)(E)	kPa	28	29	31	32	32	32	34
Available pressure head - LP pumps	(1)	kPa	142	137	133	129	129	127	127
Maximum current absorption		A	51	55	66	77	81	86	87
Star up current		A	185	183	191	246	194	254	198
Star up current with soft starter		A	111	124	139	184	122	192	137
Compressors / circuits			2 / 1	2 / 1	2 / 1	2 / 1	4 / 2	2 / 1	4 / 2
Expansion vessel volume		dm ³	12	12	12	12	12	12	12
Buffer tank volume		dm ³	220	220	220	340	340	340	340
Sound power level	(3)(E)	dB(A)	77	77	77	78	77	78	77
Transport weight unit with pump and tank		kg	762	767	847	1086	1217	1096	1217
Operating weight unit with pump and full tank		kg	982	987	1067	1426	1557	1436	1557

LCX CL			122	124	142	144	162	164	194
Power supply		V-ph-Hz	400 - 3N - 50						
Cooling capacity	(1)(E)	kW	113	116	127	133	160	152	177
Total power input	(1)(E)	kW	40,2	41,0	46,7	46,5	58,5	56,1	63,6
EER	(1)(E)		2,81	2,84	2,73	2,86	2,74	2,71	2,79
SEER	(2)(E)		3,86	4,23	3,81	3,89	4,20	3,92	4,06
Water flow	(1)	l/h	19478	20075	21965	22949	27601	26210	30574
Water pressure drop	(1)(E)	kPa	34	34	36	36	37	37	37
Available pressure head - LP pumps	(1)	kPa	115	114	170	168	162	162	155
Maximum current absorption		A	95	96	106	105	120	126	148
Star up current		A	295	220	306	222	371	241	307
Star up current with soft starter		A	230	146	241	163	288	189	245
Compressors / circuits			2 / 1	4 / 2	2 / 1	4 / 2	2 / 1	4 / 2	4 / 2
Expansion vessel volume		dm ³	24	24	24	24	24	24	24
Buffer tank volume		dm ³	600	600	600	600	600	600	600
Sound power level	(3)(E)	dB(A)	80	77	81	77	81	77	82
Transport weight unit with pump and tank		kg	1440	1455	1490	1470	1510	1620	1676
Operating weight unit with pump and full tank		kg	2040	2055	2090	2070	2110	2220	2276

(1) Outdoor air temperature 35°C, water temperature 12°C / 7°C (EN14511:2013)

(2) η efficiency values for heating and cooling are respectively calculated by the following formulas: [$\eta = SCOP / 2,5 - F(1) - F(2)$] e [$\eta = SEER / 2,5 - F(1) - F(2)$]. For further information, please refer to the technical document "ErP 2009/125/EC DIRECTIVE" in the catalogue introducing pages, or to the EN14825:2017 regulation.

(3) Sound power level measured according to ISO 9614

(E) EUROVENT certified data

LCX CL WATER CHILLERS RATED TECHNICAL DATA

LCX CL			214	244	274	294	324	364
Power supply		V-ph-Hz	400 - 3N - 50					
Cooling capacity	(1)(E)	kW	197	219	255	278	315	337
Total power input	(1)(E)	kW	74,2	83,9	90,0	107	122	150
EER	(1)(E)		2,65	2,61	2,84	2,58	2,58	2,25
SEER	(2)(E)		3,96	3,89	3,90	4,34	3,95	3,93
Water flow	(1)	l/h	33918	37691	44001	47825	54326	58016
Water pressure drop	(1)(E)	kPa	37	38	38	39	40	41
Available pressure head - LP pumps	(1)	kPa	160	190	181	168	163	142
Maximum current absorption		A	167	190	215	229	242	290
Star up current		A	318	382	398	464	472	487
Star up current with soft starter		A	256	317	333	381	389	430
Compressors / circuits			4 / 2					
Expansion vessel volume		dm ³	24	24	24	24	24	24
Buffer tank volume		dm ³	600	600	765	765	765	765
Sound power level	(3)(E)	dB(A)	82	82	84	84	84	85
Transport weight unit with pump and tank		kg	1726	1869	2129	2161	2196	2196
Operating weight unit with pump and full tank		kg	2326	2469	2894	2926	2961	2961

(1) Outdoor air temperature 35°C, water temperature 12°C / 7°C (EN14511:2013)

(2) η efficiency values for heating and cooling are respectively calculated by the following formulas: $[\eta = SCOP / 2,5 - F(1) - F(2)]$ e $[\eta = SEER / 2,5 - F(1) - F(2)]$. For further information, please refer to the technical document "ErP 2009/125/EC DIRECTIVE" in the catalogue introducing pages, or to the EN14825:2017 regulation.

(3) Sound power level measured according to ISO 9614

(E) EUROVENT certified data

LCX HL HEAT PUMPS RATED TECHNICAL DATA

LCX HL			062	072	082	092	094	102	104	
Power supply		V-ph-Hz	400 - 3N - 50							
Cooling capacity	(1)(E)	kW	57,2	65,5	77,4	87,1	88,8	100	103	
Total power input	(1)(E)	kW	20,4	23,0	26,6	31,2	31,6	35,3	36,1	
EER	(1)(E)		2,80	2,85	2,91	2,79	2,81	2,84	2,85	
SEER	(2)(E)		4,09	4,35	4,60	4,37	4,13	4,62	4,42	
Water flow	(1)	l/h	9887	11311	13349	15057	15344	17280	17761	
Water pressure drop	(1)(E)	kPa	25	25	26	25	25	29	29	
Available pressure head - LP pumps	(1)	kPa	145	141	138	136	135	129	132	
Heating capacity	(3)(E)	kW	66,7	76,1	87,9	103	105	113	118	
Total power input	(3)(E)	kW	19,1	21,4	24,9	28,8	29,6	32,3	33,8	
COP	(3)(E)		3,49	3,56	3,53	3,58	3,55	3,50	3,49	
SCOP	(2)(E)		4,17	4,38	4,38	4,36	4,13	4,03	4,19	
Heating energy efficiency class	(4)(E)		A++							
Water flow	(3)	l/h	11529	13159	15219	17805	18186	19537	20375	
Water pressure drop	(3)(E)	kPa	33	33	33	35	36	37	38	
Available pressure head - LP pumps	(3)	kPa	129	125	119	119	117	109	112	
Maximum current absorption		A	51	55	66	77	81	86	87	
Star up current		A	185	183	191	246	194	254	198	
Star up current with soft starter		A	111	124	139	184	122	192	137	
Compressors / circuits			2 / 1	2 / 1	2 / 1	2 / 1	4 / 2	2 / 1	4 / 2	
Expansion vessel volume		dm ³	12	12	12	12	12	12	12	
Buffer tank volume		dm ³	220	220	220	340	340	340	340	
Sound power level	(5)(E)	dB(A)	77	77	77	78	77	78	77	
Transport weight unit with pump and tank		kg	762	767	847	1086	1217	1096	1217	
Operating weight unit with pump and full tank		kg	982	987	1067	1426	1557	1436	1557	

LCX HL			122	124	142	144	162	164	194	
Power supply		V-ph-Hz	400 - 3N - 50							
Cooling capacity	(1)(E)	kW	112	115	126	132	158	150	176	
Total power input	(1)(E)	kW	40,6	41,2	47,1	47,1	59,6	56,5	63,6	
EER	(1)(E)		2,75	2,79	2,67	2,80	2,65	2,65	2,77	
SEER	(2)(E)		3,80	3,61	3,79	3,88	4,12	3,88	3,66	
Water flow	(1)	l/h	19227	19829	21737	22790	27297	25863	30320	
Water pressure drop	(1)(E)	kPa	27	27	29	29	34	32	33	
Available pressure head - LP pumps	(1)	kPa	122	121	177	174	163	165	158	
Heating capacity	(3)(E)	kW	135	139	148	155	183	174	206	
Total power input	(3)(E)	kW	38,0	39,4	45,1	43,7	53,0	50,8	59,9	
COP	(3)(E)		3,56	3,53	3,28	3,54	3,45	3,42	3,44	
SCOP	(2)(E)		4,38	4,22	3,95	3,74	3,77	3,91	3,80	
Heating energy efficiency class	(4)(E)		A++	A++	A++	A+	A+	A++	A++	
Water flow	(3)	l/h	23397	24032	25528	26746	31565	30026	35646	
Water pressure drop	(3)(E)	kPa	40	40	40	40	46	43	46	
Available pressure head - LP pumps	(3)	kPa	104	101	156	151	131	135	120	
Maximum current absorption		A	95	96	106	105	120	126	148	
Star up current		A	295	220	306	222	371	241	307	
Star up current with soft starter		A	230	146	241	163	288	189	245	
Compressors / circuits			2 / 1	4 / 2	2 / 1	4 / 2	2 / 1	4 / 2	4 / 2	
Expansion vessel volume		dm ³	24	24	24	24	24	24	24	
Buffer tank volume		dm ³	600	600	600	600	600	600	600	
Sound power level	(5)(E)	dB(A)	80	77	81	77	81	77	82	
Transport weight unit with pump and tank		kg	1440	1455	1490	1470	1510	1620	1676	
Operating weight unit with pump and full tank		kg	2040	2055	2090	2070	2110	2220	2276	

LCX HL HEAT PUMPS RATED TECHNICAL DATA

LCX HL			214	244	274	294	324
Power supply		V-ph-Hz	400 - 3N - 50				
Cooling capacity	(1)(E)	kW	194	216	252	274	311
Total power input	(1)(E)	kW	75,2	84,9	90,8	108	123
EER	(1)(E)		2,58	2,54	2,77	2,52	2,52
SEER	(2)(E)		3,89	3,68	3,86	3,82	3,89
Water flow	(1)	l/h	33492	37260	43482	47226	53617
Water pressure drop	(1)(E)	kPa	34	33	36	34	37
Available pressure head - LP pumps	(1)	kPa	163	195	182	172	165
Heating capacity	(3)(E)	kW	234	263	296	329	362
Total power input	(3)(E)	kW	67,3	77,5	86,2	97,4	109
COP	(3)(E)		3,47	3,39	3,43	3,38	3,33
SCOP	(2)(E)		3,80	3,97	3,78	3,82	3,91
Heating energy efficiency class	(4)(E)		A++	A++	A+	A++	A++
Water flow	(3)	l/h	40379	45351	51057	56874	62607
Water pressure drop	(3)(E)	kPa	49	49	50	49	50
Available pressure head - LP pumps	(3)	kPa	115	163	150	135	121
Maximum current absorption		A	167	190	215	229	242
Star up current		A	318	382	398	464	472
Star up current with soft starter		A	256	317	333	381	389
Compressors / circuits			4 / 2				
Expansion vessel volume		dm ³	24	24	24	24	24
Buffer tank volume		dm ³	600	600	765	765	765
Sound power level	(5)(E)	dB(A)	82	82	84	84	85
Transport weight unit with pump and tank		kg	1726	1869	2129	2161	2196
Operating weight unit with pump and full tank		kg	2326	2469	2894	2926	2961

(1) Outdoor air temperature 35°C, water temperature 12°C / 7°C (EN14511:2013)

(2) η efficiency values for heating and cooling are respectively calculated by the following formulas: [$\eta = SCOP / 2,5 - F(1) - F(2)$] e [$\eta = SEER / 2,5 - F(1) - F(2)$]. For further information, please refer to the technical document "ErP 2009/125/EC DIRECTIVE" in the catalogue introducing pages, or to the EN14825:2017 regulation.

(3) Outdoor air temperature dry bulb 7°C / wet bulb 6°C, water temperature 40°C / 45°C (EN14511:2013)

(4) Seasonal energy efficiency class for LOW TEMPERATURE room heating under AVERAGE climatic conditions [EUROPEAN REGULATION No 811/2013]

(5) Sound power level measured according to ISO 9614

(E) EUROVENT certified data

DIMENSIONAL DRAWINGS

LCX FRAME 2

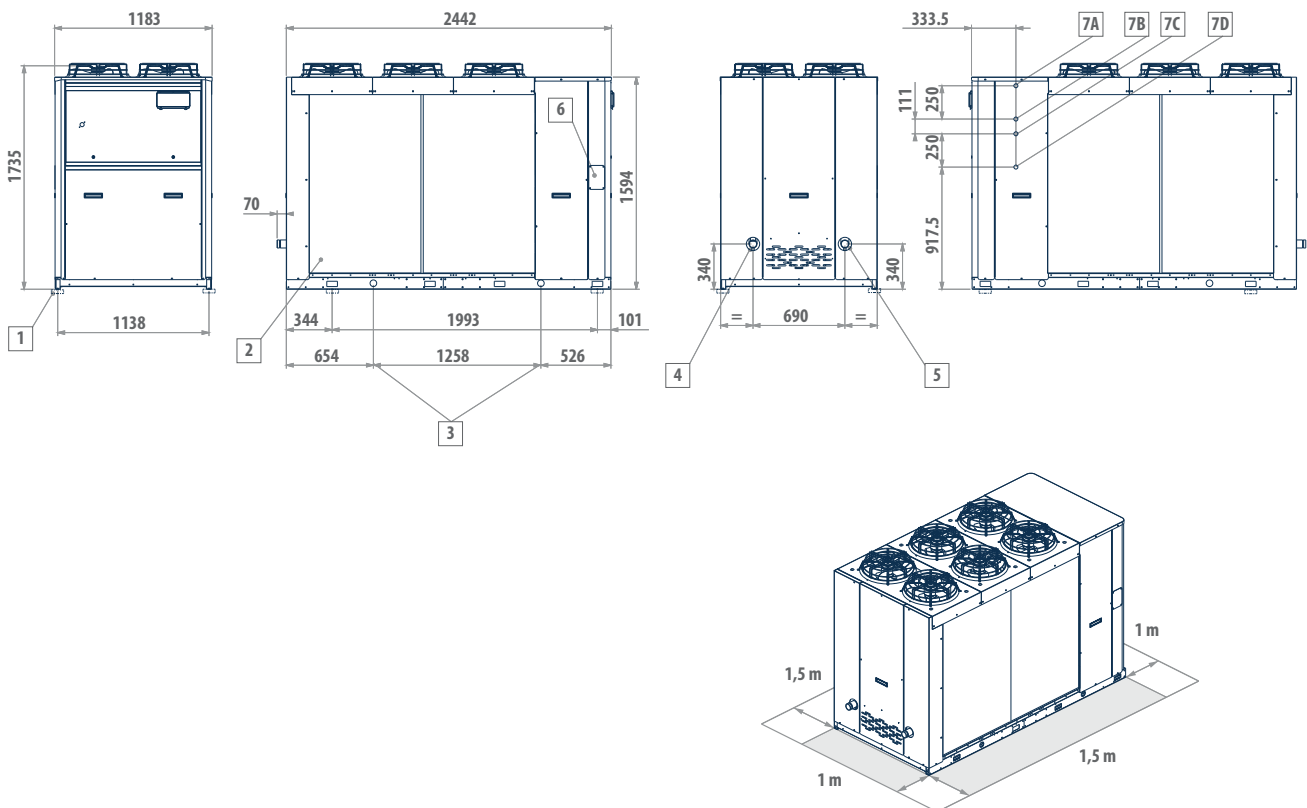

LEGEND

1	Vibration dampers
2	Protection grill (optional)
3	Lifting points
4	Water inlet (Victaulic 2")
5	Water outlet (Victaulic 2")
6	Power supply input
7A	Heat recovery water outlet (1"), left-hand circuit
7B	Heat recovery water inlet (1"), left-hand circuit
7C	Heat recovery water outlet (1"), right-hand circuit
7D	Heat recovery water inlet (1"), right-hand circuit

MODEL VERSION

LCX 62	L - Q
LCX 72	L - Q
LCX 82	L - Q
LCX 91	S
LCX 92	S
LCX 101	S
LCX 102	S

DIMENSIONAL DRAWINGS

LCX FRAME 3

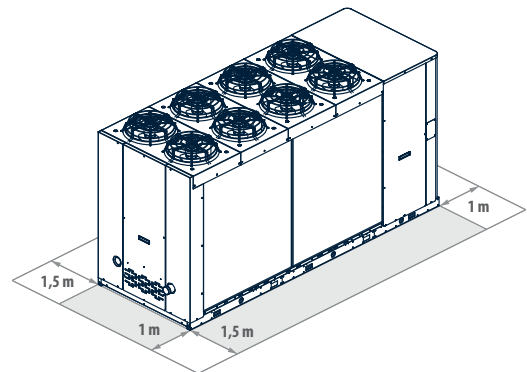
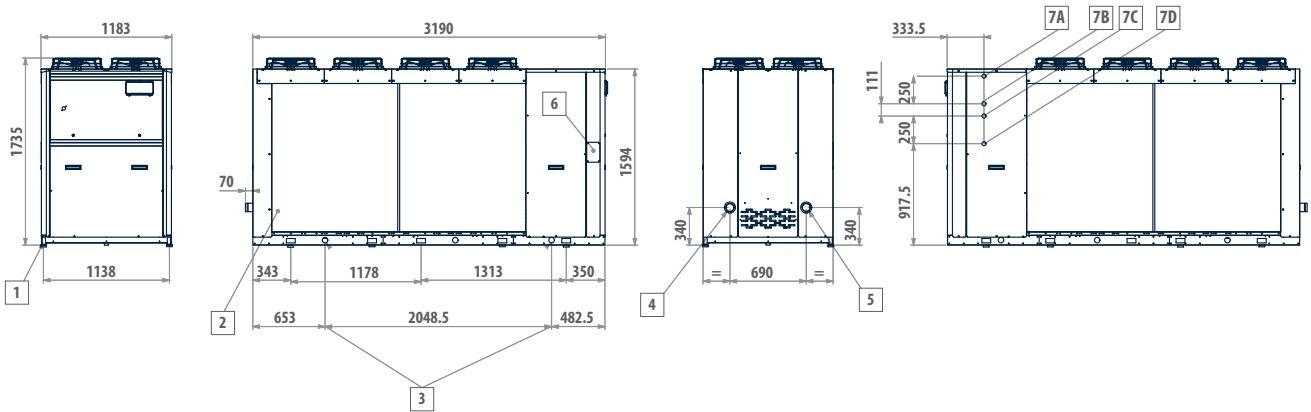

LEGEND

1	Vibration dampers
2	Protection grill (optional)
3	Lifting points
4	Water inlet (Victaulic 2 1/2")
5	Water outlet (Victaulic 2 1/2")
6	Power supply input
7A	Heat recovery water outlet (1"), left-hand circuit
7B	Heat recovery water inlet (1"), left-hand circuit
7C	Heat recovery water outlet (1"), right-hand circuit
7D	Heat recovery water inlet (1"), right-hand circuit

MODEL VERSION

LCX 91	L - Q
LCX 92	L - Q
LCX 101	L - Q
LCX 102	L - Q
LCX 121	S
LCX 122	S
LCX 141	S
LCX 142	S
LCX 161	S
LCX 162	S

DIMENSIONAL DRAWINGS

LCX FRAME 3+

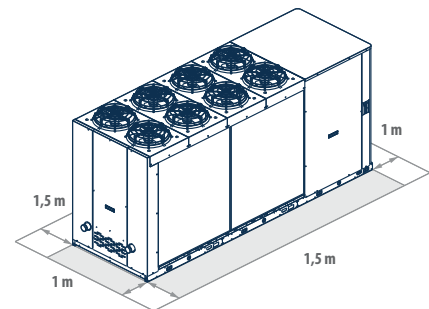
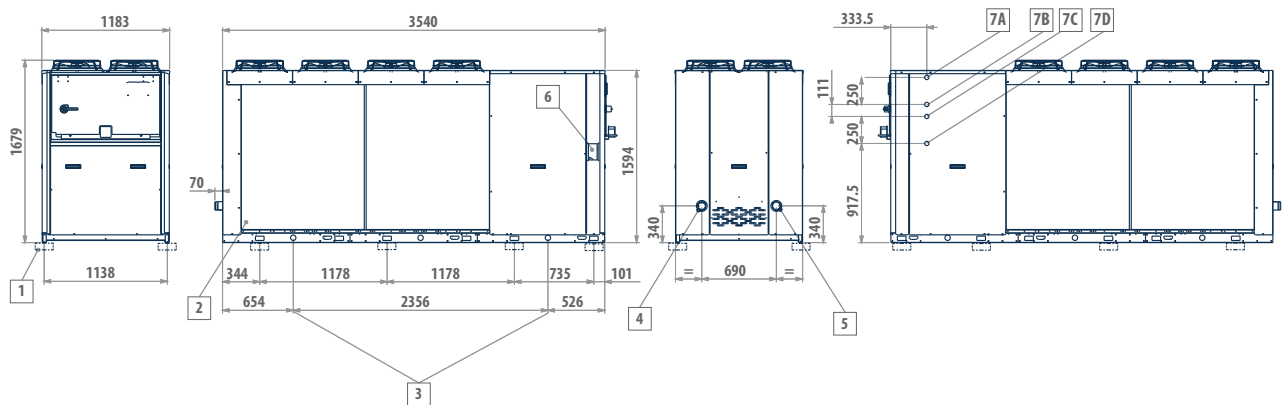

LEGEND

1	Vibration dampers
2	Protection grill (optional)
3	Lifting points
4	Water inlet (Victaulic 2 1/2")
5	Water outlet (Victaulic 2 1/2")
6	Power supply input
7A	Heat recovery water outlet (1"), left-hand circuit
7B	Heat recovery water inlet (1"), left-hand circuit
7C	Heat recovery water outlet (1"), right-hand circuit
7D	Heat recovery water inlet (1"), right-hand circuit

MODEL VERSION

LCX 94 L - Q

LCX 104 L - Q

LCX 124 S

LCX 144 S

LCX 164 S

DIMENSIONAL DRAWINGS

LCX FRAME 4

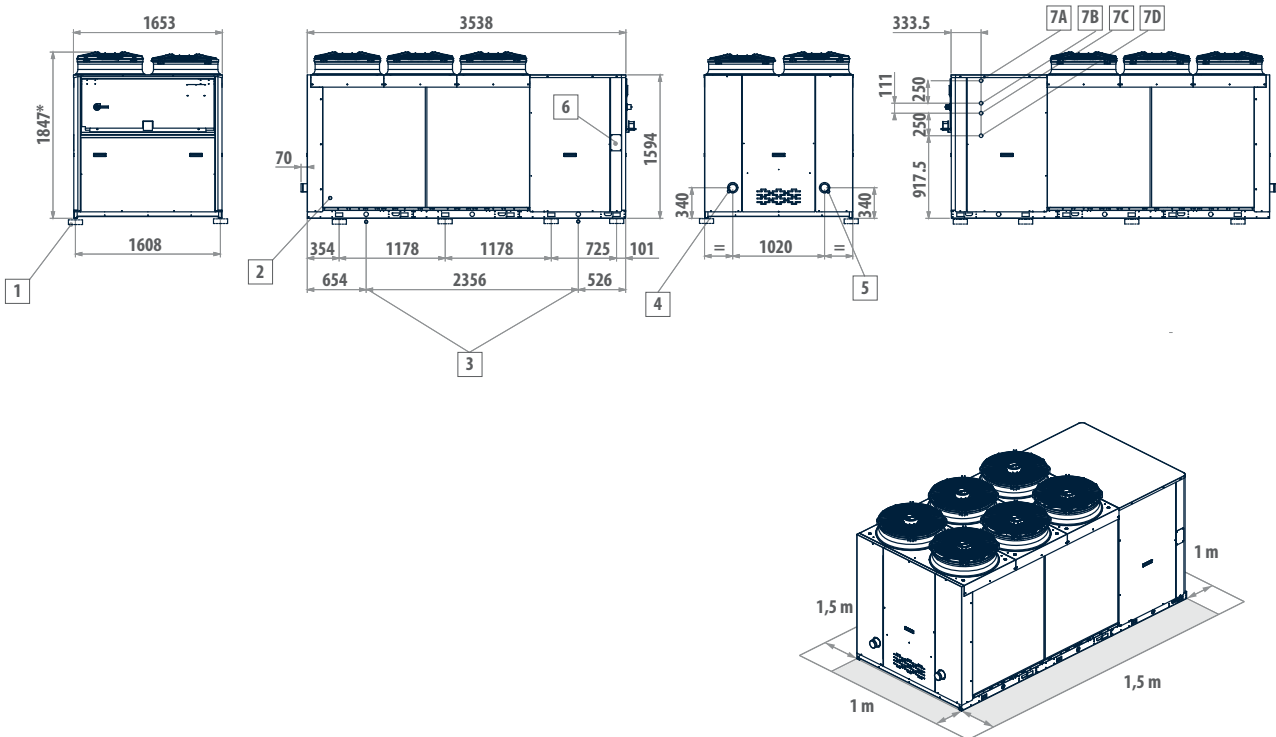

LEGEND

1	Vibration dampers
2	Protection grill (optional)
3	Lifting points (optional)
4	Water inlet (Victaulic 3")
5	Water outlet (Victaulic 3")
6	Power supply input
7A	Heat recovery water outlet (1"), left-hand circuit
7B	Heat recovery water inlet (1"), left-hand circuit
7C	Heat recovery water outlet (1"), right-hand circuit
7D	Heat recovery water inlet (1"), right-hand circuit
*	With EC=1884 fans

MODEL VERSION

LCX 121	L-Q
LCX 122	L-Q
LCX 124	L-Q
LCX 141	L-Q
LCX 142	L-Q
LCX 144	L-Q
LCX 161	L-Q
LCX 162	L-Q
LCX 164	L-Q
LCX 174	S
LCX 194	S-L-Q
LCX 214	S

DIMENSIONAL DRAWINGS

LCX FRAME 5

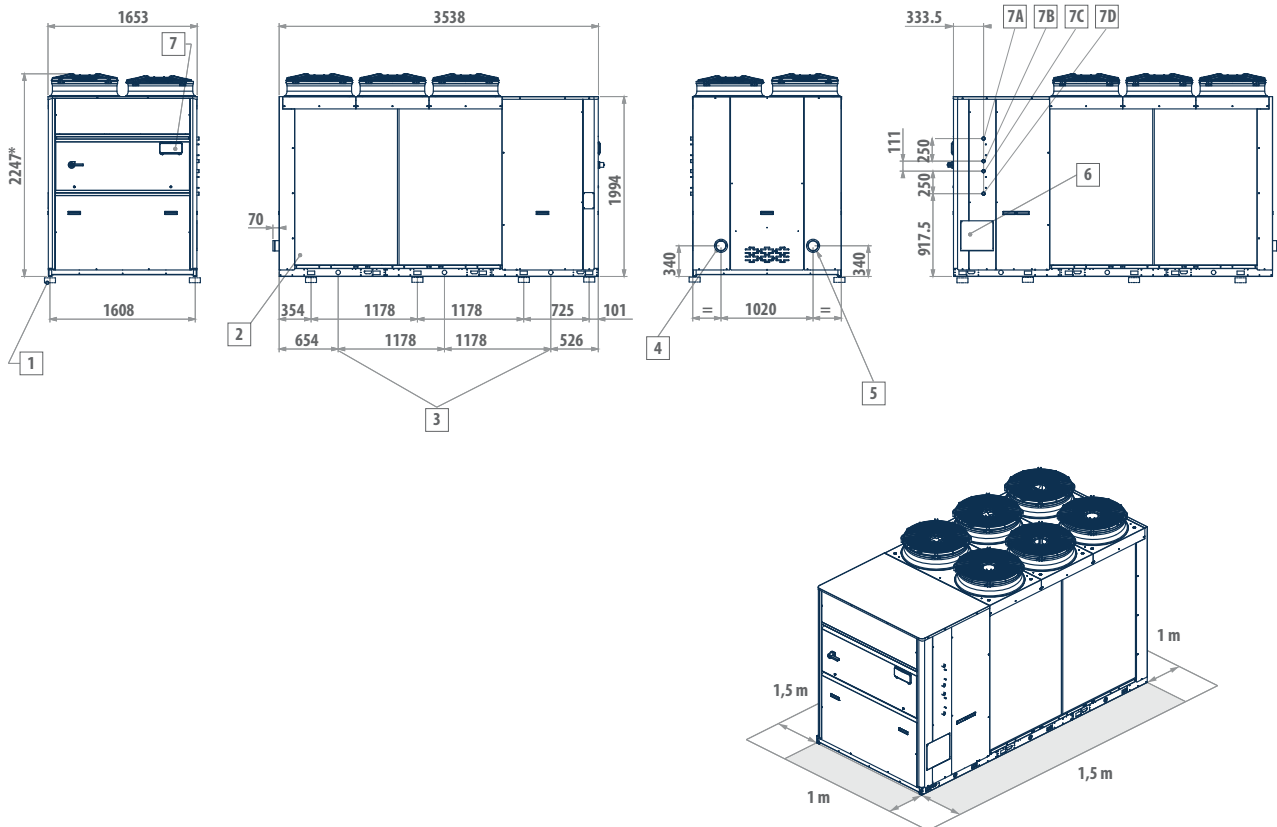

LEGEND

1	Vibration dampers
2	Protection grill (optional)
3	Lifting points (optional)
4	Water inlet (Victaulic 4")
5	Water outlet (Victaulic 4")
6	Power supply input
7A	Heat recovery water outlet (1"), left-hand circuit
7B	Heat recovery water inlet (1"), left-hand circuit
7C	Heat recovery water outlet (1"), right-hand circuit
7D	Heat recovery water inlet (1"), right-hand circuit
*	With EC=2284 fans

MODEL VERSION

LCX 214 L - Q

LCX 244 S - L - Q

DIMENSIONAL DRAWINGS

LCX FRAME 6

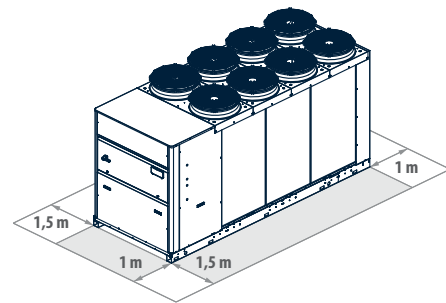
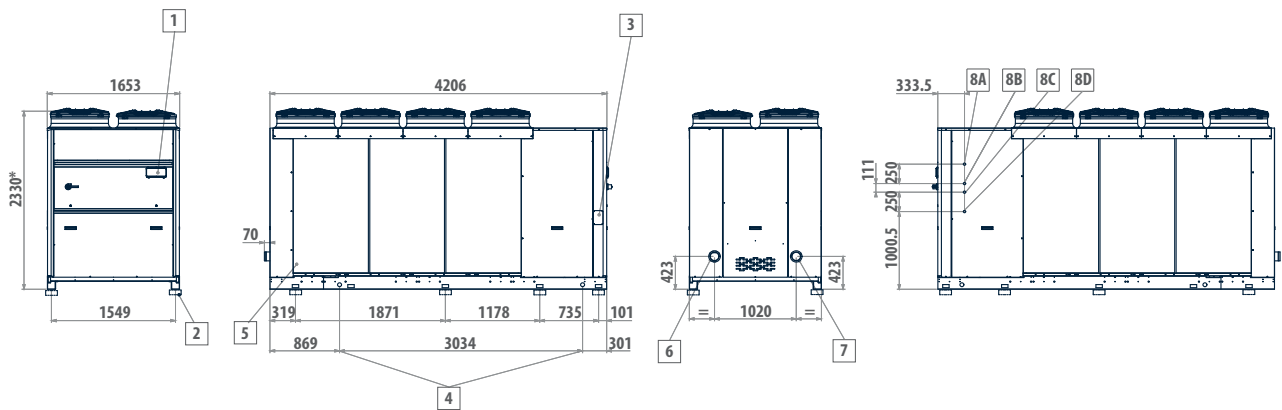

LEGEND

1	Vibration dampers
2	Protection grill (optional)
3	Lifting points (optional)
4	Water inlet (Victaulic 4")
5	Water outlet (Victaulic 4")
6	Power supply input
7A	Heat recovery water outlet (1"), left-hand circuit
7B	Heat recovery water inlet (1"), left-hand circuit
7C	Heat recovery water outlet (1"), right-hand circuit
7D	Heat recovery water inlet (1"), right-hand circuit
*	With EC=2367 fans

MODEL VERSION

LCX 274	S - L - Q
LCX 294	S - L - Q
LCX 324	S - L - Q
LCX 364	S

Outdoor packaged unit

BCX 360 - 600 kW



Available from MAY 2018



Technology and seasonal efficiency in Galletti's new solution

BCX is the new series of air-cooled heat pumps and chillers designed to meet the requirements of efficiency, configurability, reliability, and ease of maintenance. The series consists of 6 models with cooling capacities from 360 to 600 kW, in cooling only version or reversible heat pump.

In order to increase the efficiency at partial loads, trio solution (3 compressors on a circuit) were preferred and employed components and adjustment logic that make it possible to manage the water-side flow rate modulation.

High values of SEER and SCOP make the BCX series fully compliant with the provisions of the ErP Directives that regulate the requirements of eco-design.

The generously-sized finned pack heat exchanger is designed to optimize both the operation as an evaporator and as a condenser (also in terms of fin type and circuitry).

The fan sections, with their exclusive airfoil blades (HyBlade®) are characterized by extraordinary air performance and acoustics and represent the state of the art of the axial fan.

The air diffuser AxiTop® allows to raise the efficiency of the fan with benefits in terms of noise (in combination with the condensation control) and overall efficiency of the unit.

The BCX range adopts innovative solutions in the functioning and layout of the internal components of the hydraulic kit, that is now simplified to reduce connections and minimize the pressure drop on the water side inside the machine.

Each model is fully configurable with the choice of control options, hydraulic, acoustic, heat recovery without involving changes to the overall dimensions.

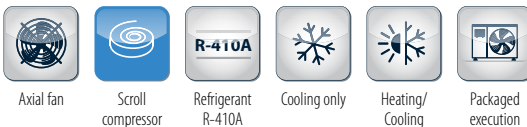

PLUS

- » High efficiency under part load conditions thanks to trio configurations
- » Intelligent modulation of the water flow rate
- » Possibility to configure low-noise versions
- » Incorporable hydraulic kit
- » HyBlade® fans
- » Remote connectivity with the most common protocols
- » Electronically controlled electronic expansion valve

MAIN COMPONENTS



Microprocessor control

The microprocessor control unit efficiently manages the BCX units, the adjustment logic, the compressors, the alarms and, in the heat pumps, the cycle switchover and defrosting thanks to the Smart Defrost System logic.

Charge monitoring

Through continuous monitoring of the cooling cycle's characteristic parameters, BCX will detect a possible reduction in the amount of refrigerant and promptly report this situation to prevent more serious problems and protect the main components.

Structure

The range is designed modularly, replicating the optimized structure of V configuration condensing coils and fans. Its design ensures stability, sturdiness even during the most critical phases (such as transportation), and maximum accessibility to components in every BCX unit.

Scroll compressors

Scroll compressors in tandem configuration or trio, with optional acoustical insulation. The levels of efficiency, reliability and noise of such components are the state of the art for the scroll compressor.

Heat exchanger

In copper pipes (8 mm diameter) and aluminum fins. The particular design criterion of the heat exchangers allows speed up the defrosting phases (for heat pump versions) with obvious benefits in terms of the integrated efficiency of the whole cycle.

Fan drive assembly

Electric fan with 6-pole external rotor motor directly keyed to the axial fan, with internal thermal protection on the windings, complete with safety grille and dedicated supporting structure. Electric fans with BLDC motor are available on request.

Low noise execution

The units can be supplied in a low-noise version, with noise-canceling headsets, acoustical enclosure for the compressors, and Axitop diffusers on the axial fans. This configuration, combined with the night attenuation function, provides a large reduction in the sound power level.

CONFIGURATOR

The models are completely configurable by selecting the version and the options. To the right is shown an example of configuration.

Version	Fields	1	2	3	4	5	6	7	8	9	10	11	12	13
BCX475CS0A		A	1	S	0	C	0	2	M	0	P	0	0	1

To verify the compatibility of the options, use the selection software or the price list.

AVAILABLE VERSIONS
Versioni solo raffreddamento

BCX..CS0A	400V-3N-50Hz power supply + circuit breakers
BCX..CS2A	400V-3-50Hz power supply + transformer + circuit breakers

Versions with reversible heat pump

BCX..HS0A	400V-3N-50Hz power supply + circuit breakers
BCX..HS2A	400V-3-50Hz power supply + transformer + circuit breakers

CONFIGURATION OPTIONS

1 Expansion valve		3 Fans noise reduction (AXITOP) + compressor sound blanket + compartment acoustic insulation
A Electronic		
2 Water pump and accessories		8 Refrigerant pipework accessories
0 Absent		0 Absent
1 LP pump + expansion vessel		M Refrigerant pressure gauges
2 LP run and standby double pump + expansion vessel		9 Remote control / Serial communication
3 HP pump + expansion vessel		0 Absent
4 HP run and standby double pump + expansion vessel		2 RS485 serial board (Carel / Modbus protocol)
A LP inverter pump + expansion vessel		B BACNET IP / PCOWEB serial board (advanced controller required)
B LP run and standby double inverter pump + expansion vessel		F BACNET MS/TP / PCONET serial board (advanced controller required)
C HP inverter pump + expansion vessel		G BACNET IP / PCOWEB serial board + supervision software Gweb (advanced controller required)
D HP run and standby double inverter pump + expansion vessel		L LON FTT10 serial board (advanced controller required)
3 Water buffer tank		S Remote simplified user panel
0 Absent		X Remote user panel for advanced controller
S Selected		10 Special coils / Protective treatments
4 Partial heat recovery		0 Standard
0 Absent		C Cataphoresis
D Desuperheater with water pump free contact		I Hydrophilic
5 Air flow modulation		P Pre-painted fins with epoxy painting
0 Absent		R Copper-copper
C Condensation control by phase-cut fans		11 Anti vibration shock mounts
E Condensation control performed by EC fans		0 Absent
6 Antifreezing kit		G Rubber anti vibration shock mounts
0 Absent		M Spring anti vibration shock mounts
E Plate exchanger		12 Compressors options
P Plate exchanger and water pump		0 Absent
S Plate exchanger, water pump and inertial tank		1 Crankcase compressor heater (CHILLER), outdoor coil trace heater (HP)
7 Acoustic insulation and attenuation		13 Onboard controller
0 Absent		1 Advanced
1 Compressor sound blanket and compressor compartment sound proofing		
2 Fans noise reduction (AXITOP)		

ACCESSORIES

A	Outdoor finned coil heat exchanger protection grille	G	Soft starter
B	Refrigerant leak alarm	H	Power factor capacitors
C	Pair of couplings Victaulic	I	Filter isolation valves kit (solenoid valve and isolation valve)
D	ON/OFF status of the compressors	L	Water pipes additional insulation
E	Remote control for step capacity limit (advanced controller required)	N	Compressor tandem/trio isolation valves
F	Configurable digital alarm board (advanced controller required)	O	Anti-intrusion grille

Air chillers and heat pumps BCX

RATED TECHNICAL DATA

BCX C		375	405	475	526	566	606
Power supply		400 - 3N - 50					
Cooling capacity	(1)(E) kW	366	402	468	523	560	591
Total power input	(1)(E) kW	127	142	170	179	197	214
EER	(1)	2,89	2,83	2,76	2,93	2,84	2,77
SEER	(2)	4,21	4,31	4,50	4,44	4,38	4,39
Water flow	(1) l/h	63137	69405	80816	90431	96769	102275
Water pressure drop	(1)(E) kPa	41	39	52	53	62	69
Available pressure head - LP pumps	(1) kPa	121	103	166	127	131	110
Available pressure head - HP pumps	(1) kPa	262	253	217	237	215	194
Maximum current absorption	A	255	318	332	370	409	422
Star up current	A	530	509	543	464	565	577
Star up current with soft starter	A	396	375	407	359	429	441
Compressors / circuits		5\2	5\2	5\2	6\2	6\2	6\2
Buffer tank volume	dm ³	700	700	700	1040	1040	1040
Expansion vessel volume	dm ³	24	24	24	24	24	24
Sound power level	(3)(E) dB(A)	95	96	96	95	96	97
Transport weight unit with pump and tank	kg	2750	2970	3484	3858	4151	4445
Operating weight unit with pump and full tank	kg	3258	3519	4127	4570	4917	5265

(1) Outdoor air temperature 35°C, water temperature 12°C / 7°C (EN14511:2013)

(2) η efficiency values for heating and cooling are respectively calculated by the following formulas: $[\eta = SCOP / 2,5 - F(1) - F(2)]$ e $[\eta = SEER / 2,5 - F(1) - F(2)]$. For further information, please refer to the technical document "ErP 2009/125/EC DIRECTIVE" in the catalogue introducing pages, or to the EN14825:2017 regulation.

(3) Sound power level measured according to ISO 9614

(E) EUROVENT certified data

RATED TECHNICAL DATA

BCX H			375	405	475	526	566	606
Power supply		V-ph-Hz	400 - 3N - 50					
Cooling capacity	(1)(E)	kW	353	388	451	502	539	571
Total power input	(1)(E)	kW	132	149	179	190	208	225
EER	(1)(E)		2,67	2,60	2,52	2,64	2,59	2,54
SEER	(2)		4,10	4,15	4,28	4,16	4,13	4,10
Water flow	(1)	l/h	60933	67019	77847	86650	93192	98708
Water pressure drop	(1)(E)	kPa	41	39	52	53	62	69
Available pressure head - LP pumps	(1)	kPa	131	114	181	147	144	124
Available pressure head - HP pumps	(1)	kPa	268	260	227	249	227	208
Heating capacity	(3)(E)	kW	409	447	533	580	622	662
Total power input	(3)(E)	kW	133	147	173	191	205	219
COP	(3)(E)		3.06	3.04	3.08	3.03	3.02	3.02
SCOP	(2)(E)		3,60	3,74	3,97	3,56	3,63	3,83
Heating energy efficiency class	(4)		A+	A+	A++	A+	A+	A++
Water flow	(3)	l/h	70022	76611	91225	99264	106341	113231
Water pressure drop	(3)(E)	kPa	49	46	65	64	73	83
Available pressure head - LP pumps	(3)	kPa	94	73	116	83	101	73
Available pressure head - HP pumps	(3)	kPa	245	236	187	212	186	159
Maximum current absorption		A	256	319	332	369	408	421
Star up current		A	530	509	543	464	565	577
Star up current with soft starter		A	401	421	466	442	517	528
Compressors / circuits			5\2	5\2	5\2	6\2	6\2	6\2
Buffer tank volume		dm ³	700	700	700	1040	1040	1040
Expansion vessel volume		dm ³	24	24	24	24	24	24
Sound power level	(5)(E)	dB(A)	95	96	96	95	96	97
Transport weight unit with pump and tank		kg	2948	3184	3735	4136	4450	4765
Operating weight unit with pump and full tank		kg	3456	3732	4378	4848	5216	5585

(1) Outdoor air temperature 35°C, water temperature 12°C / 7°C (EN14511:2013)

(2) η efficiency values for heating and cooling are respectively calculated by the following formulas: [$\eta = SCOP / 2,5 - F(1) - F(2)$] e [$\eta = SEER / 2,5 - F(1) - F(2)$]. For further information, please refer to the technical document "ErP 2009/125/EC DIRECTIVE" in the catalogue introducing pages, or to the EN14825:2017 regulation.

(3) Outdoor air temperature dry bulb 7°C / wet bulb 6°C, water temperature 40°C / 45°C (EN14511:2013)

(4) Seasonal energy efficiency class for LOW TEMPERATURE room heating under AVERAGE climatic conditions [EUROPEAN REGULATION No 811/2013]

(5) Sound power level measured according to ISO 9614

(E) EUROVENT certified data

DIMENSIONAL DRAWINGS

BCX 375 - 475

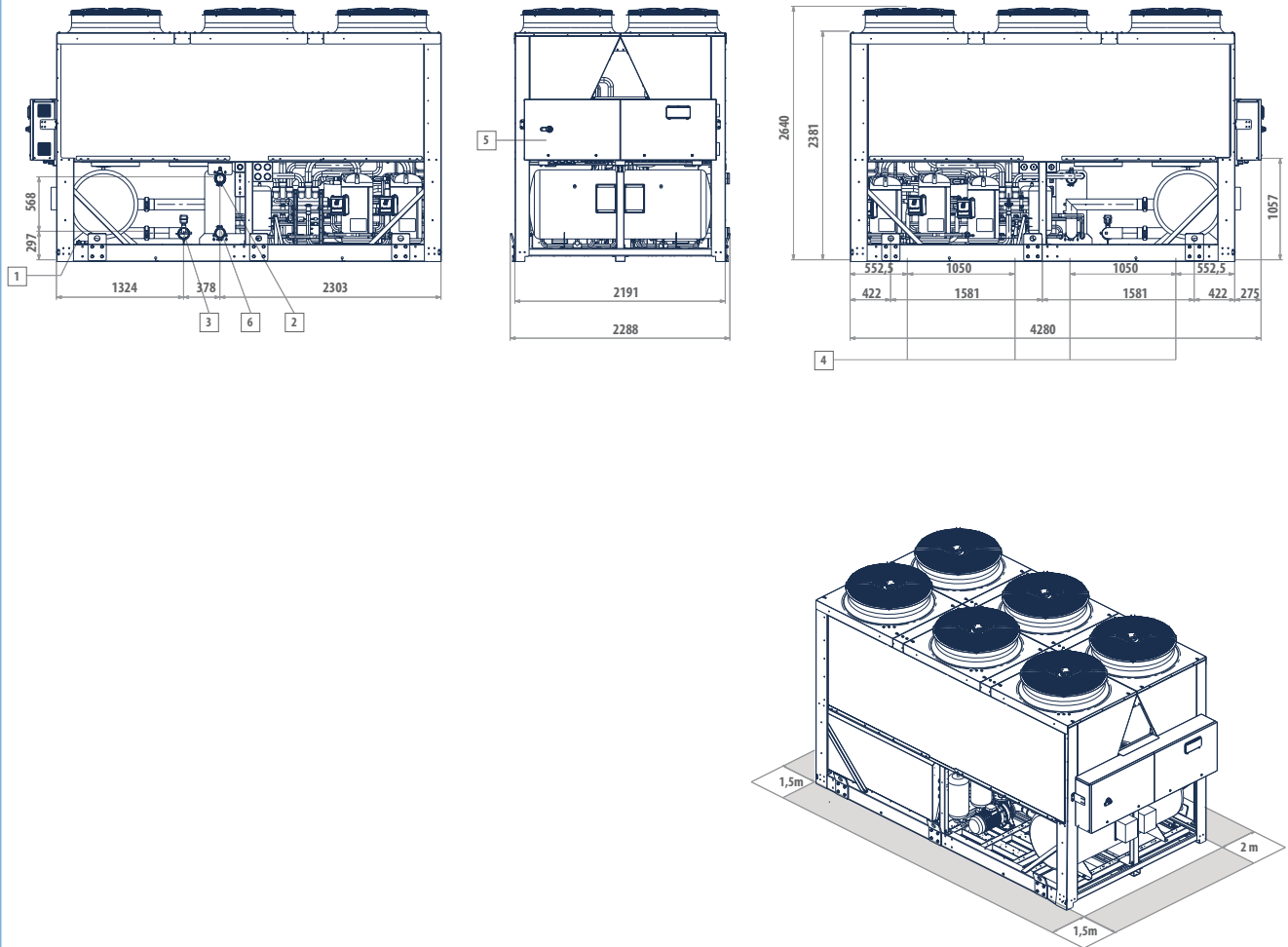

LEGEND

- | | |
|---|-------------------------------|
| 1 | Water drainage |
| 2 | Water inlet Victaulic 4" |
| 3 | Water outlet Victaulic 4" |
| 4 | Vibration dumpers |
| 5 | Electric control board |
| 6 | Water outlet, evaporator only |

DIMENSIONAL DRAWINGS

BCX 526 - 606

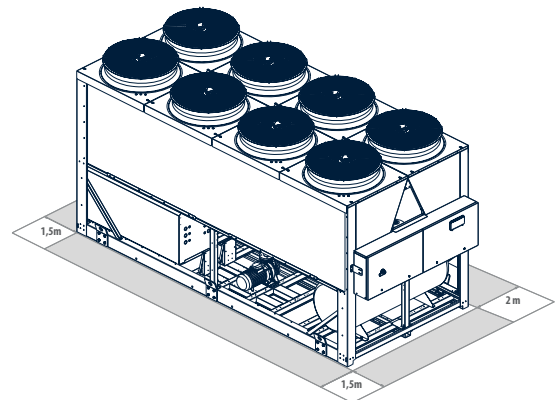
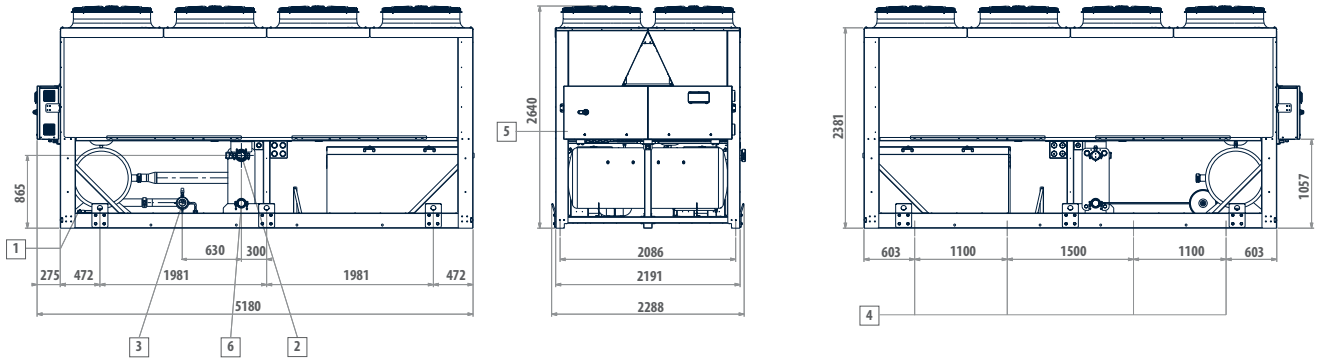

LEGEND

1	Water drainage
2	Water inlet Victaulic 4"
3	Water outlet Victaulic 4"
4	Vibration dumpers
5	Electric control board
6	Water outlet, evaporator only

Outdoor packaged unit

LSE 360 - 1200 kW



Multi-scroll solutions for reliability and high efficiency at partial loads

Though a water chiller or heat pump is chosen on the basis of the maximum load of the system it is intended to serve, the actual thermal load of an air conditioning system is less than 60% of the rated load capacity 90% of the time. This range of LSE heat pumps and chillers was designed to handle this type of use in the most efficient manner; it is comprised of 14 models with cooling capacities from 370 to 1200 kW (650 kW with heat pump) and employs scroll compressors in a tandem or trio connection configuration on 2 or 4 cooling circuits. The high number of capacity control steps of this solution enables the unit to adapt its power to the actual needs of the system, with particular gains in efficiency under partial load conditions compared to traditional screw compressors. During operation under part load conditions, the compressors work with oversized exchange surfaces so as to achieve more advantageous thermodynamic cycles, thanks also to the use of an electronic expansion valve, a standard feature of all models

The microprocessor control unit automatically manages turning on the compressors depending on the required thermal load and ensures rotation according to the number of hours of operation with consequent increase in the duration. LSE is available also in a free-cooling version, to reduce energy consumption when it is necessary to produce chilled water during the coldest season of the year, with silenced operation in order to comply with noise containment regulations.

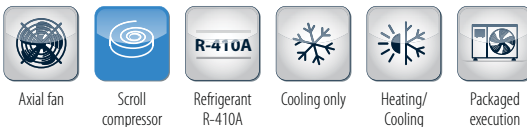

PLUS

- » High efficiency when operating at partial load
- » Electronically controlled electronic expansion valve
- » Incorporable hydronic kit
- » High configurability and wide availability of accessories
- » Compact dimensions

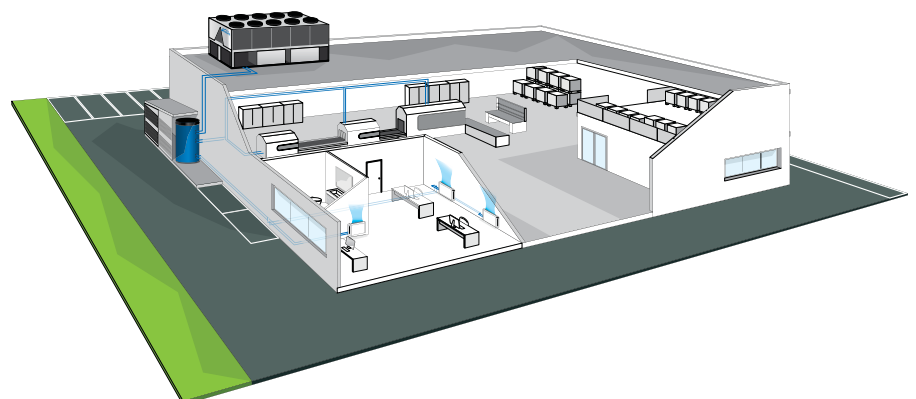

The "W" configuration of the finned block heat exchangers makes it possible to have a large amount of exchange surface with a small footprint, thereby resulting in machines with high power density.

MAIN COMPONENTS

Structure

Painted galvanised sheet steel structure for an effective resistance to corrosive agents. Compressor compartment located below the finned heat exchangers to reduce the dimensions without compromising performance.

Compressors

Hermetic scroll compressors driven by electric motors and connected in tandem or trio version to maximize efficiency at partial loads.

Electronically controlled electronic expansion valve

It represents, together with the compressor, the key component for the proper functioning of the unit. It optimizes the machines' operation at partial loads and increases the average seasonal energy efficiency.

Heat exchangers

Finned heat exchangers with copper pipes and aluminum fins in a "W" configuration to allow alternating defrosting operations and to minimize the negative effects on the system.

Microprocessor control

The microprocessor control unit efficiently manages the LSE units, the adjustment logic, the compressors, the alarms and, in the heat pumps, the cycle switchover and defrosting thanks to the Smart Defrost System logic.



Hydraulic kit

Option of choosing one or two pumps at standard or high head to meet system requirements, suitable for operation with glycol up to 30% and can be combined with a heat buffer tank.

CONFIGURATOR

The models are completely configurable by selecting the version and the options. To the right is shown an example of configuration.

Version	Fields	1	2	3	4	5	6	7	8	9	10	11	12
LSE558CL		0	B	4	S	0	C	0	2	0	0	M	3

To verify the compatibility of the options, use the selection software or the price list.

AVAILABLE VERSIONS

Cooling only versions

LSE..CS	Standard execution
LSE..CL	Low noise execution

Versions with reversible heat pump

LSE..HS	Standard execution
LSE..HL	Low noise execution

CONFIGURATION OPTIONS

1 Power supply

- 0 400 V - 3 N - 50 Hz
- 1 400 V - 3 - 50 Hz
- 2 400 V - 3 N - 50 Hz + magnetic breakers
- 3 400 V - 3 - 50 Hz + magnetic breakers

2 Onboard controller and expansion valve

- B Advanced + electronic expansion valve
- C Advanced + mechanical expansion valve

3 User side water pump

- 0 Absent
- 1 LP pump + expansion vessel
- 2 HP pump + expansion vessel
- 3 Double pump LP parallel operation and expansion vessel (advanced controller required)
- 4 Double pump HP parallel operation and expansion vessel (advanced controller required)
- 5 LP run and standby double pump + expansion vessel
- 6 HP run and standby double pump + expansion vessel

4 Water buffer tank

- 0 Absent
- S Selected

5 Partial heat recovery

- 0 Absent
- D Desuperheater with water pump free contact

6 Air flow modulation

- 0 Absent
- C Condensation control by phase-cut fans
- E Condensation control performed by EC fans

7 Antifreezing kit

- 0 Absent
- E Evaporator

P Evaporator and water pump

S Evaporator, water pump and water buffer tank

8 Remote communication

- 0 Absent
- 1 RS485 serial board (Carel / Modbus protocol)
- 2 LON FTT10 serial board (advanced controller required)
- 3 GSM modem board (advanced controller required)
- 4 BACNET IP / PCOWEB serial board + supervision software Gweb (advanced controller required)
- 5 BACNET IP / PCOWEB serial board + clock board + supervision software Gweb (advanced controller required)

9 Special coils / Protective treatments

- 0 Standard
- B Pre-painted fins with epoxy painting
- C Cataphoresis
- R Copper-copper

10 Packing

- 0 Standard
- 1 Wooden cage
- 2 Wooden crate

11 Anti vibration shock mounts

- 0 Absent
- G Rubber anti vibration shock mounts
- M Spring anti vibration shock mounts

12 Remote control

- 0 Absent
- 1 Remote simplified user panel
- 3 Remote simplified user panel for advanced controller

ACCESSORIES

A	Power factor capacitors	H	Set point compensation outdoor temperature probe
B	Soft starter	I	Refrigerant pressure gauges
C	Service kit (advanced controller required)	L	Filter isolation valves kit (solenoid valve and isolation valve)
D	Pair of couplings Victaulic	M	Directives reference other than "2014/68/UE - PED"
E	ON/OFF status of the compressors	N	Clock board (advanced controller required)
F	Remote control for step capacity limit (advanced controller required)	P	Outdoor finned coil heat exchanger protection grille
G	Configurable digital alarm board (advanced controller required)	Q	Outdoor finned coil heat exchanger protection filters

LSE CS WATER CHILLERS RATED TECHNICAL DATA

LSE CS			374	416	456	486	536	558	618
Power supply		V-ph-Hz	400 - 3N - 50						
Cooling capacity	(1)(E)	kW	363	404	453	486	536	561	602
Total power input	(1)(E)	kW	134	151	160	175	210	196	213
EER	(1)(E)		2,71	2,68	2,83	2,78	2,55	2,86	2,82
SEER	(2)(E)		4,37	4,61	4,50	4,59	4,17	4,34	4,38
Water flow	(1)	l/h	62608	69676	78155	83846	92478	96705	103833
Water pressure drop	(1)(E)	kPa	52	53	56	50	52	46	48
Available pressure head - LP pumps	(1)	kPa	165	142	188	173	138	161	143
Available pressure head - HP pumps	(1)	kPa	260	248	271	266	247	245	244
Maximum current absorption		A	316	352	362	382	420	462	480
Star up current		A	454	506	563	578	563	596	637
Star up current with soft starter		A	295	329	366	376	366	387	414
Compressors / circuits			4 / 2	6 / 2	6 / 2	6 / 2	6 / 2	8 / 4	8 / 4
Expansion vessel volume - unit with pumps		dm ³	24	24	24	24	24	24	24
Expansion vessel volume - unit with pump and tank		dm ³	48	48	48	48	48	48	48
Buffer tank volume		dm ³	600	600	600	600	600	1040	1040
Sound power level	(3)(E)	dB(A)	90	90	91	91	91	92	92
Transport weight unit with pump and tank		kg	2875	3320	3691	3715	3716	4622	4707
Operating weight unit with pump and full tank		kg	3475	3920	4291	4315	4316	5662	5747

LSE CS			658	748	800	900	942	1072	1202
Power supply		V-ph-Hz	400 - 3N - 50						
Cooling capacity	(1)(E)	kW	644	714	772	906	946	1071	1200
Total power input	(1)(E)	kW	231	276	296	336	349	418	461
EER	(1)(E)		2,79	2,58	2,61	2,70	2,71	2,56	2,60
SEER	(2)(E)		4,44	4,29	4,39	4,65	4,51	4,19	4,28
Water flow	(1)	l/h	110961	123008	133149	156086	163152	184568	206806
Water pressure drop	(1)(E)	kPa	49	51	58	56	60	51	55
Available pressure head - LP pumps	(1)	kPa	210	179	145	186	174	154	118
Available pressure head - HP pumps	(1)	kPa	237	265	250	282	270	252	216
Maximum current absorption		A	506	564	631	765	771	792	975
Star up current		A	648	677	738	781	871	890	1190
Star up current with soft starter		A	421	440	480	508	566	578	774
Compressors / circuits			8 / 4	8 / 4	10 / 4	10 / 4	12 / 4	12 / 4	12 / 4
Expansion vessel volume - unit with pumps		dm ³	24	24	24	24	24	24	24
Expansion vessel volume - unit with pump and tank		dm ³	48	48	48	48	48	48	48
Buffer tank volume		dm ³	1040	1040	1040	1040	1040	1040	1040
Sound power level	(3)(E)	dB(A)	92	92	92	93	93	93	95
Transport weight unit with pump and tank		kg	4972	5411	5610	6248	6486	6626	7890
Operating weight unit with pump and full tank		kg	6012	6451	6650	7288	7526	7666	8930

(1) Outdoor air temperature 35°C, water temperature 12°C / 7°C (EN14511:2013)

(2) η efficiency values for heating and cooling are respectively calculated by the following formulas: $[\eta = SCOP / 2,5 - F(1) - F(2)]$ e $[\eta = SEER / 2,5 - F(1) - F(2)]$. For further information, please refer to the technical document "ErP 2009/125/EC DIRECTIVE" in the catalogue introducing pages, or to the EN14825:2017 regulation.

(3) Sound power level measured according to ISO 9614

(E) EUROVENT certified data

LSE CL WATER CHILLERS RATED TECHNICAL DATA

LSE CL			374	416	456	486	536	558	618
Power supply		V-ph-Hz	400 - 3N - 50						
Cooling capacity	(1)(E)	kW	351	388	440	471	515	545	583
Total power input	(2)(E)	kW	138	156	162	178	219	198	217
EER	(1)(E)		2,57	2,52	2,74	2,67	2,37	2,78	2,71
SEER	(3)(E)		4,23	4,23	4,20	4,26	4,44	4,62	4,64
Water flow	(2)	l/h	60362	66689	75507	80958	88499	93675	100169
Water pressure drop	(2)(E)	kPa	49	49	53	47	47	43	45
Available pressure head - LP pumps	(2)	kPa	175	156	201	187	159	170	154
Available pressure head - HP pumps	(2)	kPa	266	257	279	274	260	254	249
Maximum current absorption		A	305	343	347	368	405	442	462
Star up current		A	442	497	556	573	548	576	619
Star up current with soft starter		A	287	323	361	372	356	374	402
Compressors / circuits			4 / 2	6 / 2	6 / 2	6 / 2	6 / 2	8 / 4	8 / 4
Expansion vessel volume - unit with pumps		dm ³	24	24	24	24	24	24	24
Expansion vessel volume - unit with pump and tank		dm ³	48	48	48	48	48	48	48
Buffer tank volume		dm ³	600	600	600	600	600	1040	1040
Sound power level	(4)(E)	dB(A)	82	82	83	83	83	84	84
Transport weight unit with pump and tank		kg	2980	3440	3811	3855	3856	4802	4887
Operating weight unit with pump and full tank		kg	3580	4040	4411	4455	4456	5842	5927

LSE CL			658	748	800	900	942	1072	1202
Power supply		V-ph-Hz	400 - 3N - 50						
Cooling capacity	(1)(E)	kW	621	692	743	874	914	1022	1178
Total power input	(2)(E)	kW	237	283	304	348	359	442	470
EER	(1)(E)		2,65	2,46	2,46	2,53	2,57	2,33	2,53
SEER	(3)(E)		4,58	4,53	4,63	4,37	4,17	4,37	4,37
Water flow	(2)	l/h	106662	118788	127603	150102	156955	175580	202321
Water pressure drop	(2)(E)	kPa	46	48	54	51	56	47	53
Available pressure head - LP pumps	(2)	kPa	223	192	164	197	185	170	127
Available pressure head - HP pumps	(2)	kPa	243	271	259	292	280	267	225
Maximum current absorption		A	488	542	609	743	749	767	975
Star up current		A	630	656	716	759	851	869	1190
Star up current with soft starter		A	410	426	465	493	553	565	774
Compressors / circuits			8 / 4	8 / 4	10 / 4	10 / 4	12 / 4	12 / 4	12 / 4
Expansion vessel volume - unit with pumps		dm ³	24	24	24	24	24	24	24
Expansion vessel volume - unit with pump and tank		dm ³	48	48	48	48	48	48	48
Buffer tank volume		dm ³	1040	1040	1040	1040	1040	1040	1040
Sound power level	(4)(E)	dB(A)	84	85	85	85	87	90	92
Transport weight unit with pump and tank		kg	5152	5516	5715	6488	6726	6966	7890
Operating weight unit with pump and full tank		kg	6192	6556	6755	7528	7766	8006	8930

(1) Outdoor air temperature 35°C, water temperature 12°C / 7°

(2) Outdoor air temperature 35°C, water temperature 12°C / 7°C (EN14511:2013)

(3) η efficiency values for heating and cooling are respectively calculated by the following formulas: $[\eta = SCOP / 2,5 - F(1) - F(2)]$ e $[\eta = SEER / 2,5 - F(1) - F(2)]$. For further information, please refer to the technical document "ErP 2009/125/EC DIRECTIVE" in the catalogue introducing pages, or to the EN14825:2017 regulation.

(4) Sound power level measured according to ISO 9614

(E) EUROVENT certified data

LSE HS HEAT PUMPS RATED TECHNICAL DATA

LSE HS		374	416	456	486	536	558	618	658
Power supply		400 - 3N - 50							
Cooling capacity	(1)(E) kW	363	404	453	486	536	561	602	644
Total power input	(1)(E) kW	134	151	160	175	210	196	213	231
EER	(1)(E)	2,71	2,68	2,83	2,78	2,55	2,86	2,82	2,79
SEER	(2)(E)	4,21	4,54	4,48	4,57	4,16	4,13	4,19	4,25
Water flow	(1) l/h	62608	69676	78155	83846	92478	96705	103833	110961
Water pressure drop	(1)(E) kPa	52	53	56	50	52	46	48	49
Available pressure head - LP pumps	(1) kPa	165	142	188	173	138	161	143	210
Available pressure head - HP pumps	(1) kPa	260	248	271	266	247	245	244	237
Heating capacity	(3)(E) kW	424	470	516	553	624	651	700	748
Total power input	(3)(E) kW	130	142	156	166	191	192	207	221
COP	(3)(E)	3,27	3,31	3,31	3,33	3,27	3,39	3,38	3,38
SCOP	(2)(E)	3,78	3,52	3,35	3,40	3,51	3,65	3,68	3,71
Heating energy efficiency class	(4)(E)	A+							
Water flow	(3) l/h	73388	81350	89265	95556	107783	112689	121079	129468
Water pressure drop	(3)(E) kPa	66	66	67	72	77	56	59	60
Available pressure head - LP pumps	(3) kPa	117	88	135	106	48	112	87	151
Available pressure head - HP pumps	(3) kPa	227	213	237	220	188	197	216	208
Maximum current absorption	A	316	352	362	382	465	462	480	506
Star up current	A	454	506	563	578	563	596	637	648
Star up current with soft starter	A	295	329	366	376	366	387	414	421
Compressors / circuits		4 / 2	6 / 2	6 / 2	6 / 2	6 / 2	8 / 4	8 / 4	8 / 4
Buffer tank volume	dm ³	600	600	600	600	600	1040	1040	1040
Sound power level	(5)(E) dB(A)	90	90	91	91	91	92	92	92
Transport weight unit with pump and tank	kg	3015	3460	3831	3875	3876	4872	4957	5172
Operating weight unit with pump and full tank	kg	3615	4060	4431	4475	4476	5912	5997	6212

(1) Outdoor air temperature 35°C, water temperature 12°C / 7°C (EN14511:2013)

(2) η efficiency values for heating and cooling are respectively calculated by the following formulas: $[\eta = SCOP / 2,5 - F(1) - F(2)]$ e $[\eta = SEER / 2,5 - F(1) - F(2)]$. For further information, please refer to the technical document "ErP 2009/125/EC DIRECTIVE" in the catalogue introducing pages, or to the EN14825:2017 regulation.

(3) Outdoor air temperature dry bulb 7°C / wet bulb 6°C, water temperature 40°C / 45°C (EN14511:2013)

(4) Seasonal energy efficiency class for LOW TEMPERATURE room heating under AVERAGE climatic conditions [EUROPEAN REGULATION No 811/2013]

(5) Sound power level measured according to ISO 9614

(E) EUROVENT certified data

LSE HL HEAT PUMPS TECHNICAL DATA

LSE HL			374	416	456	486	536	558	618	658
Power supply		V-ph-Hz	400 - 3N - 50							
Cooling capacity	(1)(E)	kW	350	387	438	470	514	544	581	619
Total power input	(1)(E)	kW	138	156	162	178	219	198	217	237
EER	(1)(E)		2,53	2,49	2,70	2,64	2,34	2,75	2,68	2,62
SEER	(2)(E)		4,23	4,21	4,18	4,24	4,43	4,48	4,51	4,47
Water flow	(1)	l/h	60362	66689	75507	80958	88499	93675	100169	106662
Water pressure drop	(1)(E)	kPa	49	49	53	47	47	43	45	46
Available pressure head - LP pumps	(1)	kPa	175	156	201	187	159	170	154	223
Available pressure head - HP pumps	(1)	kPa	266	257	279	274	260	254	249	243
Heating capacity	(3)(E)	kW	420	460	514	550	618	645	687	730
Total power input	(3)(E)	kW	126	138	151	161	186	186	200	214
COP	(3)(E)		3,33	3,34	3,40	3,41	3,32	3,47	3,43	3,40
SCOP	(2)(E)		3,96	3,84	3,70	3,73	3,84	3,97	3,93	3,91
Heating energy efficiency class	(4)(E)		A++	A++	A+	A+	A++	A++	A++	A++
Water flow	(3)	l/h	72612	79665	88854	95116	106768	111648	118965	126281
Water pressure drop	(3)(E)	kPa	64	64	66	71	76	55	57	58
Available pressure head - LP pumps	(3)	kPa	121	97	138	108	54	115	94	162
Available pressure head - HP pumps	(3)	kPa	230	218	239	221	192	200	220	213
Maximum current absorption		A	305	343	347	368	451	442	462	488
Star up current		A	442	497	556	573	548	576	619	630
Star up current with soft starter		A	287	323	361	372	356	374	402	410
Compressors / circuits			4 / 2	6 / 2	6 / 2	6 / 2	6 / 2	8 / 4	8 / 4	8 / 4
Buffer tank volume		dm ³	600	600	600	600	600	1040	1040	1040
Sound power level	(5)(E)	dB(A)	82	82	83	83	83	84	84	84
Transport weight unit with pump and tank		kg	3120	3580	3951	3995	3996	5052	5137	5402
Operating weight unit with pump and full tank		kg	3720	4180	4551	4595	4596	6092	6177	6442

(1) Outdoor air temperature 35°C, water temperature 12°C / 7°C (EN14511:2013)

(2) η efficiency values for heating and cooling are respectively calculated by the following formulas: [$\eta = SCOP / 2,5 - F(1) - F(2)$] e [$\eta = SEER / 2,5 - F(1) - F(2)$]. For further information, please refer to the technical document "ErP 2009/125/EC DIRECTIVE" in the catalogue introducing pages, or to the EN14825:2017 regulation.

(3) Outdoor air temperature dry bulb 7°C / wet bulb 6°C, water temperature 40°C / 45°C (EN14511:2013)

(4) Seasonal energy efficiency class for LOW TEMPERATURE room heating under AVERAGE climatic conditions [EUROPEAN REGULATION No 811/2013]

(5) Sound power level measured according to ISO 9614

(E) EUROVENT certified data

DIMENSIONAL DRAWINGS

LSE 374 - 416

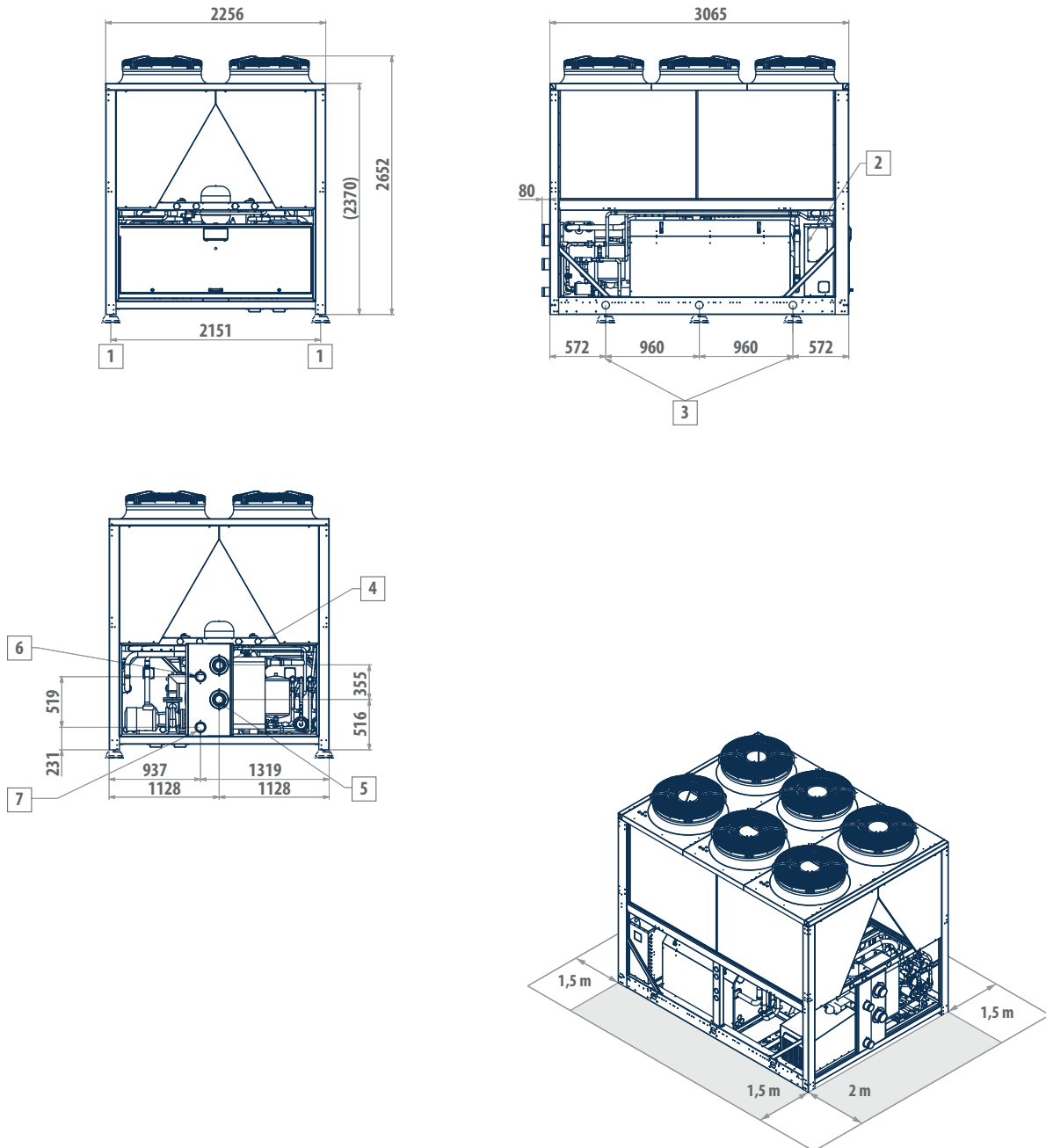

LEGEND

1	Vibration dampers
2	Power supply input
3	Lifting points
4	Water inlet (4" Victaulic)
5	Water outlet (4" Victaulic)
6	Optional heat recovery water outlet (Victaulic 3")
7	Optional heat recovery water inlet (Victaulic 3")

DIMENSIONAL DRAWINGS

LSE 456 - 486 - 536

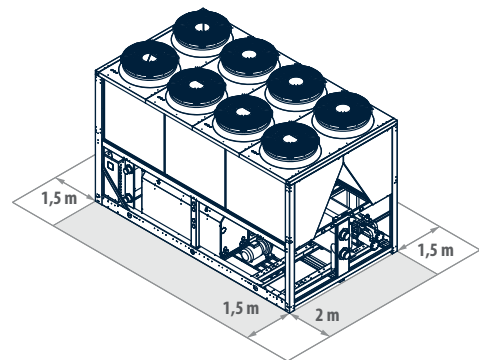
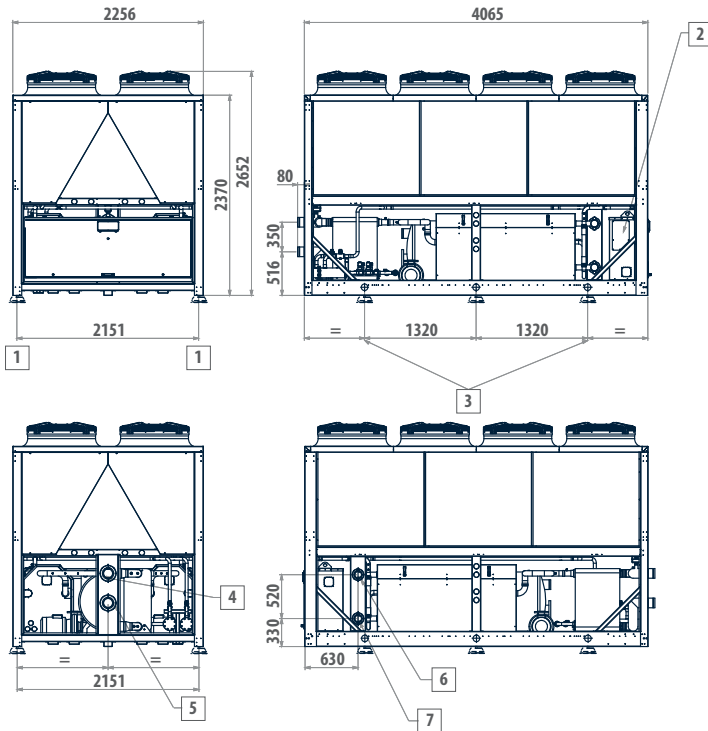

LEGEND

1	Vibration dampers
2	Power supply input
3	Lifting points
4	Water inlet (4" Victaulic)
5	Water outlet (4" Victaulic)
6	Optional heat recovery water outlet (Victaulic 3")
7	Optional heat recovery water inlet (Victaulic 3")

DIMENSIONAL DRAWINGS

LSE 558 - 618 - 658

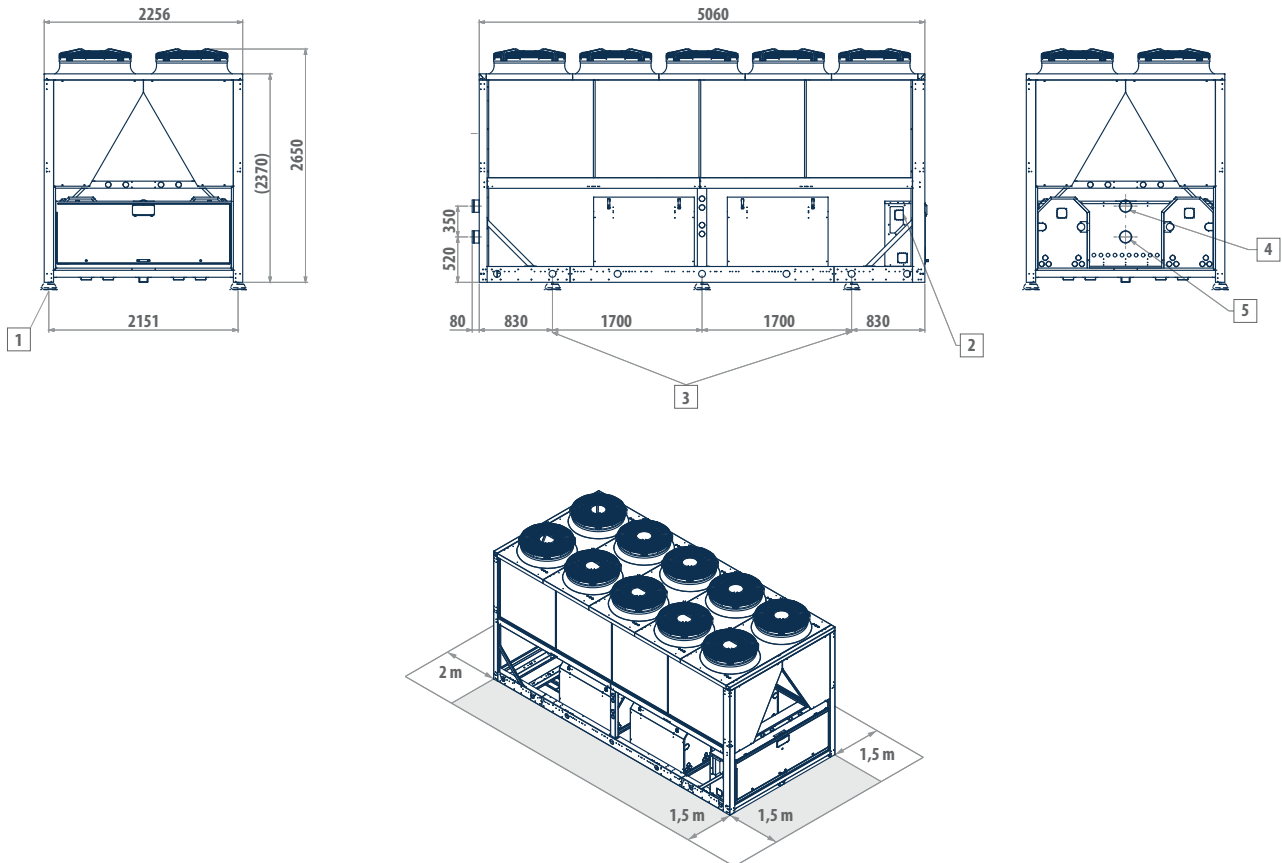

LEGEND

- | | |
|---|-----------------------------|
| 1 | Vibration dampers |
| 2 | Power supply input |
| 3 | Lifting points |
| 4 | Water inlet (5" Victaulic) |
| 5 | Water outlet (5" Victaulic) |

DIMENSIONAL DRAWINGS

LSE 748 - 800

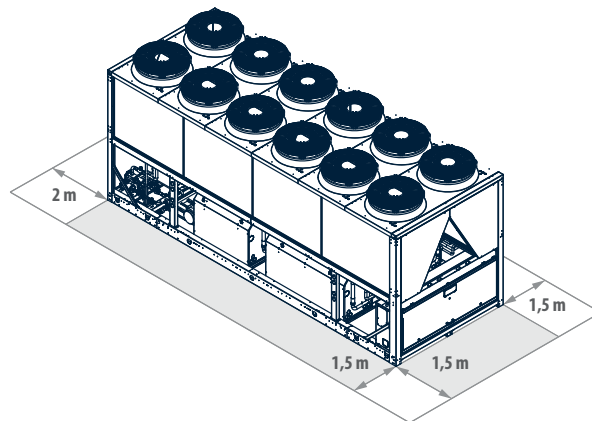
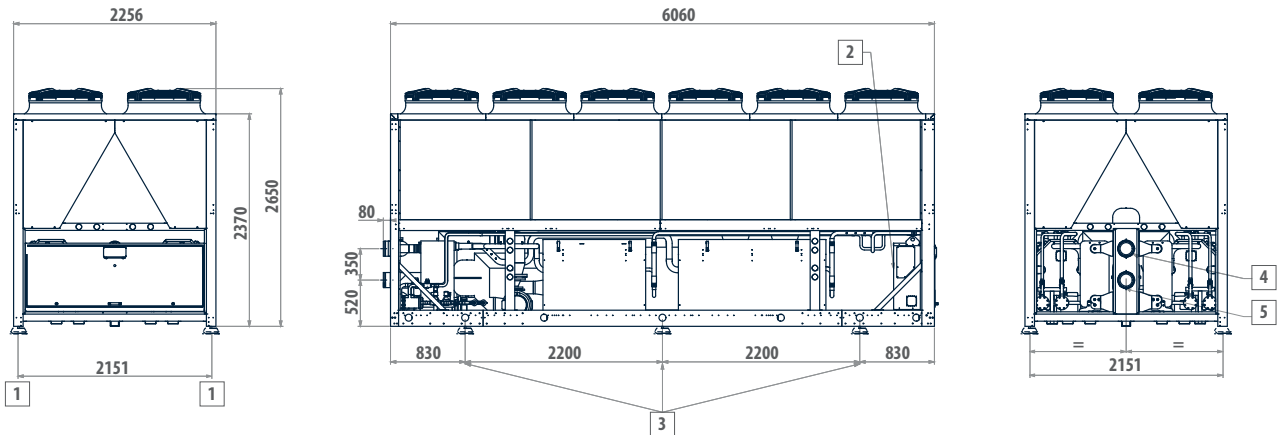

LEGEND

- | | |
|---|-----------------------------|
| 1 | Vibration dampers |
| 2 | Power supply input |
| 3 | Lifting points |
| 4 | Water inlet (6" Victaulic) |
| 5 | Water outlet (6" Victaulic) |

DIMENSIONAL DRAWINGS

LSE 900 - 942 - 1072

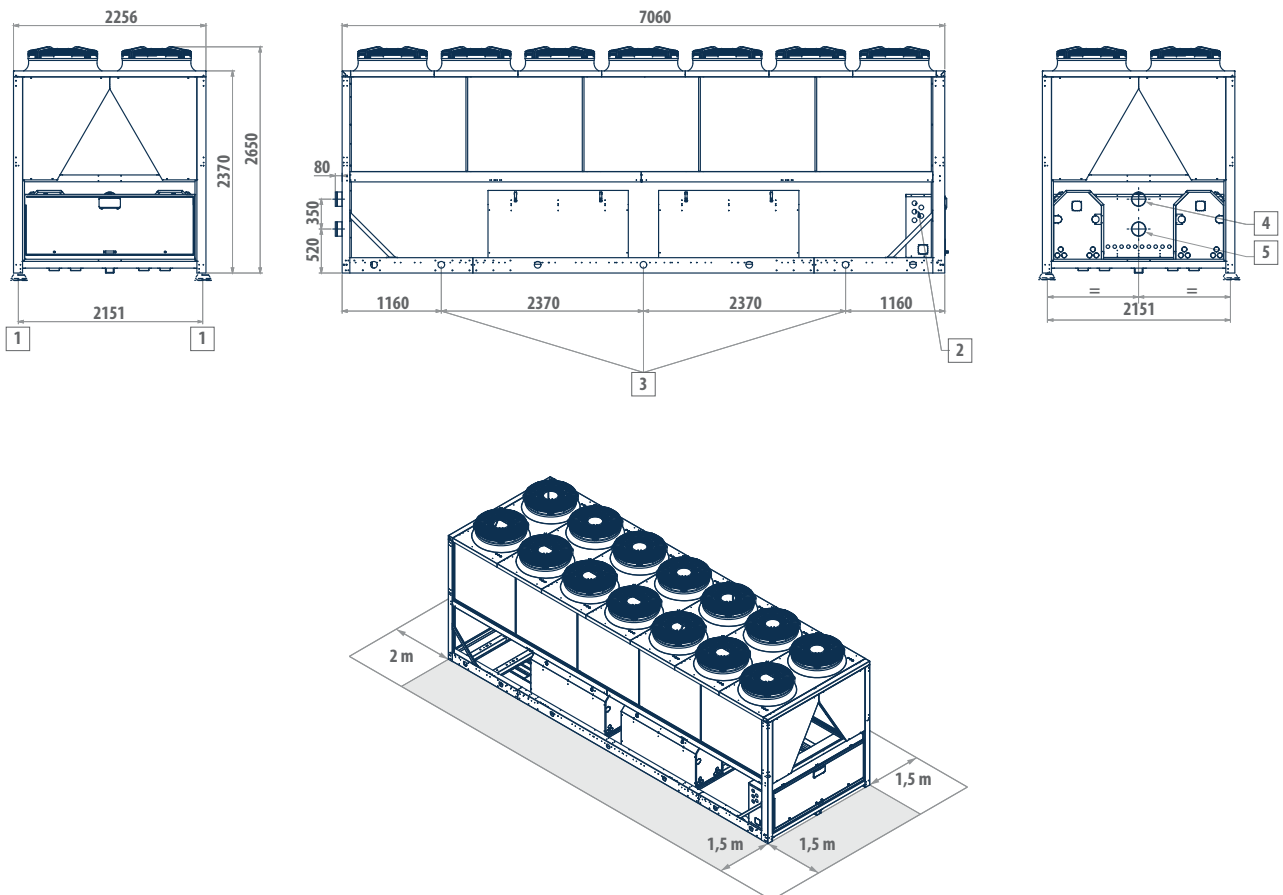

LEGEND

- | | |
|---|-----------------------------|
| 1 | Vibration dampers |
| 2 | Power supply input |
| 3 | Lifting points |
| 4 | Water inlet (6" Victaulic) |
| 5 | Water outlet (6" Victaulic) |

DIMENSIONAL DRAWINGS

LSE 1202

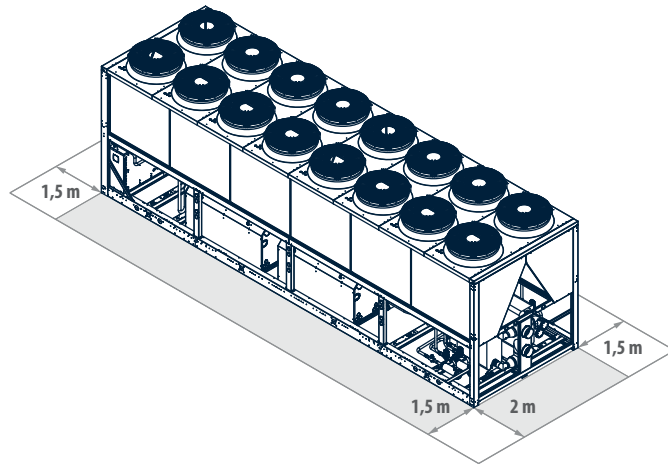
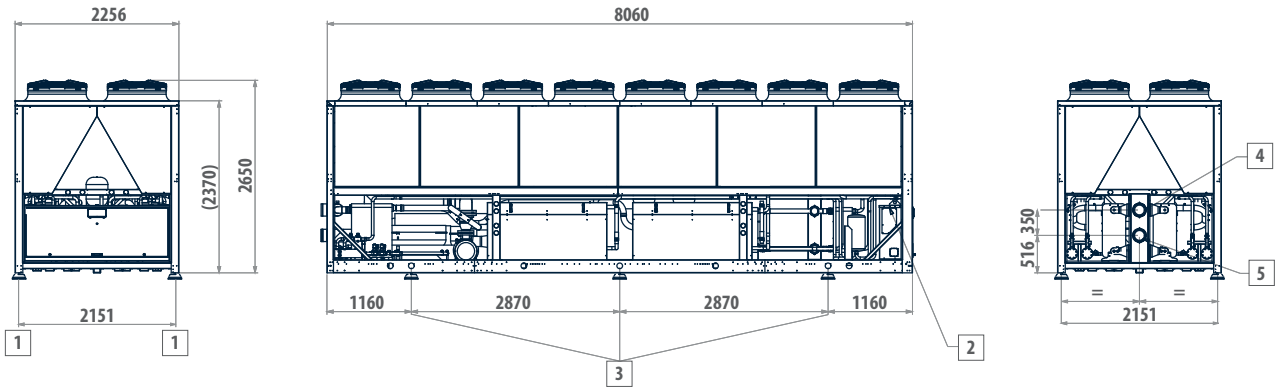

LEGEND

1	Vibration dampers
2	Power supply input
3	Lifting points
4	Water inlet (6" Victaulic)
5	Water outlet (6" Victaulic)
6	Optional heat recovery water outlet (Victaulic 4")
7	Optional heat recovery water inlet (Victaulic 4")

Outdoor motor-driven condensing units

MTE 5 - 205 kW



Efficiency and compactness for commercial air conditioning

MTE Air-cooled motocondensing packaged units are designed for outdoor installation in both residential and industrial applications.

The range uses R410A refrigerant, which assures high levels of performance with relatively low energy consumption and features 29 models in the chiller version, with cooling capacities ranging from 5 to 213 kW.

These units are employed in 2-section systems, which are normally connected to air evaporator coils in ducted air conditioning units.

Its extreme compactness facilitates the handling and installation of the units, even in situations with reduced installation space.

The equipment compartment is completely sealed and may be accessed on 3 sides thanks to easy-to-remove panels that greatly simplify maintenance and/or inspection. On request sound insulation makes it possible to further reduce the unit's noise emissions.

The cooling circuit is completely precharged with nitrogen. The liquid receiver (available as an optional accessory) compensates for variations in the load that occur in the system when the operating conditions change (day/night - summer/winter). Its use is also recommended for long sections of the circuit.



Axial fan



Scroll compressor



Refrigerant R-410A



Cooling only



Split version

PLUS

- » Compact dimensions
- » Up to 4 compressors
- » 1 or 2 cooling circuits
- » Remote connectivity with the most common protocols

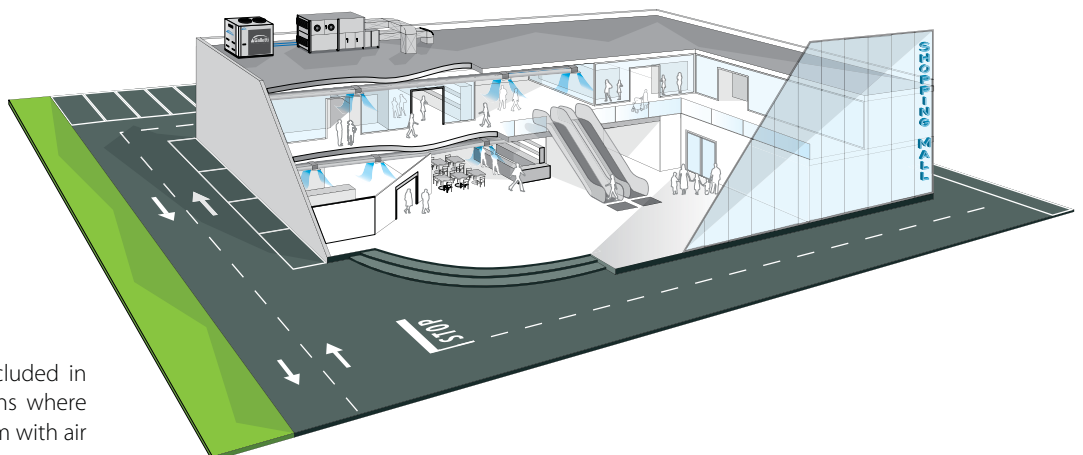

MTE condensing units are included in typical commercial applications where it is necessary to combine them with air evaporating units.

MAIN COMPONENTS

Structure

Painted galvanised sheet steel structure (RAL9002) for an effective resistance to corrosive agents. Fastening devices are made of non-oxidizable materials, or carbon steel that has undergone surface-passivating treatments.

Fan drive assembly

Axial fans with airfoil blades made of plastic-aluminum composite, connected to an electric motor with external rotor. The condensation control system continuously and automatically regulates the fan speed.

Compressor

Hermetic scroll type (rotary up to 7 kW), housed in a completely closed compartment that can be sound insulated. There is a heating element (standard feature) on the compressor's cover to counter oil dilution.

Electric control board

Electrical control panel with microprocessor controller accessible from the outside and low-voltage output for dry-contact thermostat control of the unit, external disconnect switch, phase sequence control.

Cooling circuit

- Dehydrating filter
- Flow indicator with humidity indicator
- High and low pressure switch
- Security valve
- Shut-off valves on the liquid and gas line
- Nitrogen precharge under pressure
- Thermostatic valve, refrigerant pressure gauges, and liquid receiver as optional accessories

Heat exchanger

Made of 8 mm diameter copper pipes and aluminium fins, generously sized. A protection grille is available as an accessory.



CONFIGURATOR

The models are completely configurable by selecting the version and the options. To the right is shown an example of configuration.

Version	Fields	1	2	3	4	5	6	7	8	9	10	11	12	13
MTE074C0AA		0	2	S	0	C	1	1	M	0	0	G	1	1

To verify the compatibility of the options, use the selection software or the price list.

AVAILABLE VERSIONS

Cooling only versions

MTE...COAA Unit with 400V - 3N - 50 Hz power supply
MTE...CMAA Unit with 230V - 1 - 50 Hz power supply

CONFIGURATION OPTIONS

- | | |
|--|---|
| <p>1 Expansion valve</p> <ul style="list-style-type: none"> 0 Absent A Electronic T Mechanical <p>2 Liquid receiver</p> <ul style="list-style-type: none"> 0 Absent 2 Present with valve <p>3 Refrigerant circuit accessories</p> <ul style="list-style-type: none"> 0 Absent S Solenoid valve <p>4 Partial heat recovery</p> <ul style="list-style-type: none"> 0 Absent <p>5 Air flow modulation</p> <ul style="list-style-type: none"> 0 Absent C Condensation control by phase-cut fans <p>6 Phase sequence switch</p> <ul style="list-style-type: none"> 0 Absent 1 Present (only 400 V - 3 N - 50 Hz) <p>7 Acoustic insulation and attenuation</p> <ul style="list-style-type: none"> 0 Absent 1 Compressor compartment acoustic insulation 2 Compressor sound blanket 3 Compressor compartment acoustic insulation and sound blanket | <p>8 Refrigerant pipework accessories</p> <ul style="list-style-type: none"> 0 Absent M Refrigerant pressure gauges <p>9 Remote control / Serial communication</p> <ul style="list-style-type: none"> 0 Absent 2 RS485 serial board (Carel / Modbus protocol) M Remote simplified user panel for standard controller S Remote simplified user panel <p>10 Special coils / Protective treatments</p> <ul style="list-style-type: none"> 0 Standard B Pre-painted fins with epoxy painting C Cataphoresis R Copper-copper <p>11 Outdoor finned coil heat exchanger protection</p> <ul style="list-style-type: none"> 0 Absent G Outdoor finned coil heat exchanger protection grille <p>12 Compressors options</p> <ul style="list-style-type: none"> 0 Absent 1 Crankcase compressor heater 2 Soft starter <p>13 Onboard controller</p> <ul style="list-style-type: none"> 1 Basic |
|--|---|

ACCESSORIES

RYKAMF Spring anti vibration shock mounts

RYPAM Rubber anti vibration shock mounts

Motor-driven condensing units MTE

MTE MOTOCONDENSING UNITS RATED TECHNICAL DATA

MTE C			005M	007M	009	009M	010	010M	012	013
Power supply		V-ph-Hz	230 - 1 - 50	230 - 1 - 50	400 - 3N - 50	230 - 1 - 50	400 - 3N - 50	230 - 1 - 50	400 - 3N - 50	400 - 3N - 50
Cooling capacity	(1)	kW	5,40	7,16	8,88	8,83	9,71	9,71	12,5	13,7
Total power input	(1)	kW	1,71	2,28	3,09	3,33	3,27	3,27	4,25	4,31
EER	(2)		3,16	3,14	2,87	2,65	2,97	2,97	2,93	3,17
Maximum current absorption		A	12	16	7	20	9	23	11	11
Star up current		A	57	57	41	57	43	87	57	57
Compressors / circuits			1 / 1							
Sound power level	(3)	dB(A)	67	67	67	67	69	69	69	70
Transport / operating weight		kg	72	85	94	94	165	165	168	170

MTE C			015	018	021	024	029	033	038	042
Power supply		V-ph-Hz	400 - 3N - 50							
Cooling capacity	(1)	kW	15,6	18,5	21,0	24,7	28,7	32,4	37,9	42,6
Total power input	(1)	kW	5,33	6,59	7,39	8,24	10,1	11,7	12,2	13,3
EER	(2)		2,92	2,81	2,84	2,99	2,84	2,78	3,11	3,20
Maximum current absorption		A	13	17	18	20	28	31	34	36
Star up current		A	59	66	92	92	117	147	142	144
Compressors / circuits			1 / 1							
Sound power level	(3)	dB(A)	70	77	77	77	80	80	80	82
Transport / operating weight		kg	170	175	190	204	230	239	259	360

MTE C			053	059	066	074	082	096	108	129
Power supply		V-ph-Hz	400 - 3N - 50							
Cooling capacity	(1)	kW	53,6	59,2	67,0	74,6	82,2	112	112	141
Total power input	(1)	kW	16,0	17,9	20,9	23,3	27,0	37,7	37,7	43,9
EER	(2)		3,36	3,31	3,21	3,20	3,04	2,97	2,97	3,20
Maximum current absorption		A	46	49	56	61	69	81	90	103
Star up current		A	196	202	218	237	262	295	339	363
Compressors / circuits			2 / 1							
Sound power level	(3)	dB(A)	76	76	76	77	80	82	82	82
Transport / operating weight		kg	525	530	540	570	650	730	730	1010

MTE C			142	163	169	193	214
Power supply		V-ph-Hz	400 - 3N - 50				
Cooling capacity	(1)	kW	141	166	166	166	166
Total power input	(1)	kW	43,9	56,8	59,3	59,3	59,3
EER	(2)		3,20	2,92	2,80	2,80	2,80
Maximum current absorption		A	113	136	137	155	174
Star up current		A	379	467	349	416	450
Compressors / circuits			2 / 1	2 / 1	4 / 2	4 / 2	4 / 2
Sound power level	(3)	dB(A)	82	83	83	84	84
Transport / operating weight		kg	1055	1085	1330	1460	1470

(1) Outdoor air temperature 35°C, evaporation temperature 5°

(2) Outdoor air temperature 35°C, evaporation temperature 5°

(3) Sound power level measured according to ISO 9614

DIMENSIONAL DRAWINGS

MTE 05 - 09

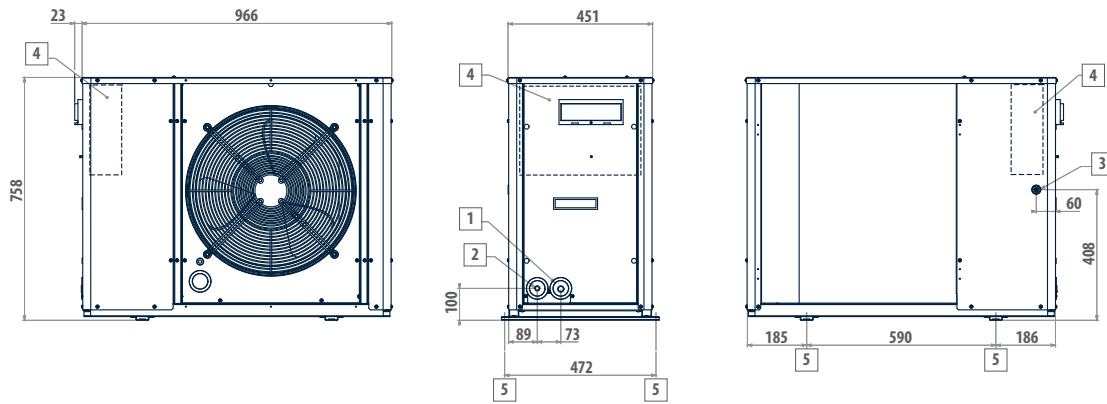

LEGEND

- | | |
|---|--|
| 1 | Gas inlet \varnothing 12 MTE 5; \varnothing 16 MTE 07-09 |
| 2 | Liquid outlet \varnothing 12 |
| 3 | Power supply \varnothing 37 |
| 4 | Electric control board |
| 5 | Vibration dumpers |

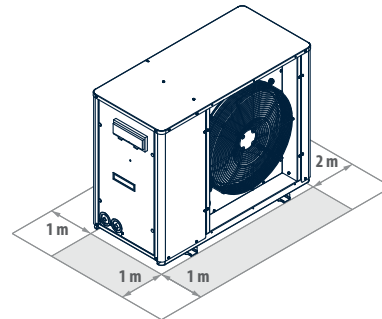

MTE 10 - 24

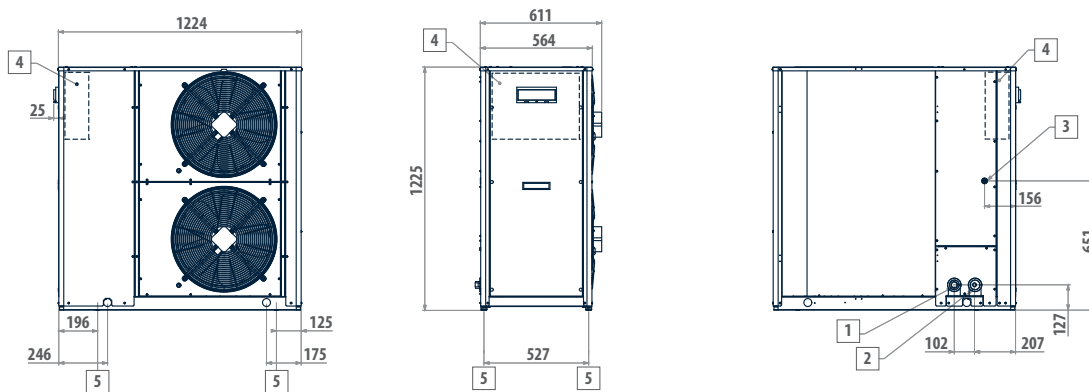

LEGEND

- | | |
|---|--|
| 1 | Gas inlet \varnothing 22 MTE 10-18; \varnothing 28 mm MTE 21-24 |
| 2 | Liquid outlet \varnothing 12 MTE 10-18; \varnothing 16 MTE 21-24 |
| 3 | Power supply \varnothing 37 |
| 4 | Electric control board |
| 5 | Vibration dumpers |

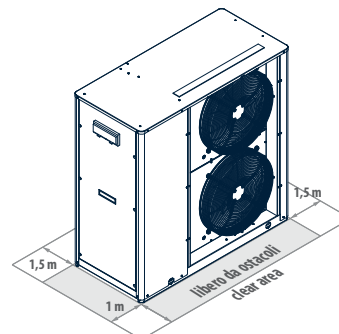

Motor-driven condensing units MTE

DIMENSIONAL DRAWINGS

MTE 29 - 38

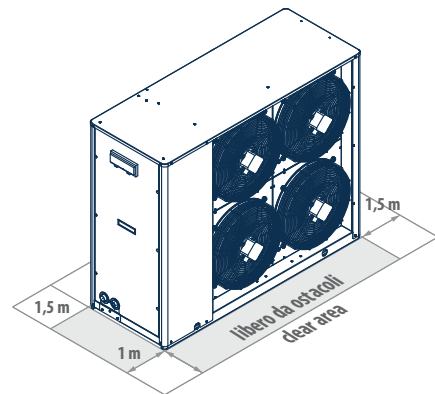
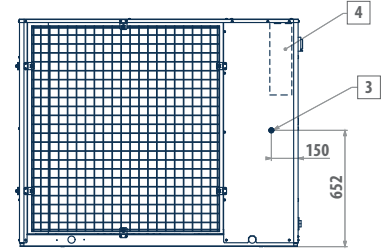
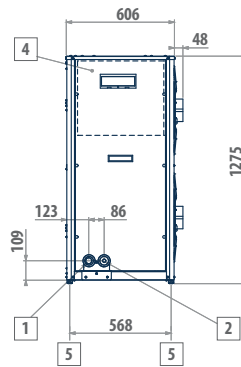
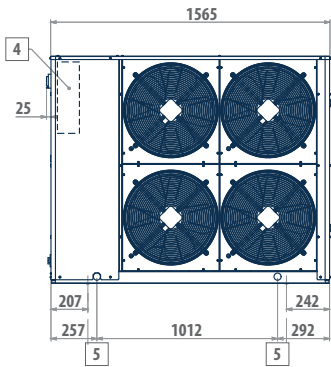

LEGEND

- | | |
|---|--------------------------------|
| 1 | Gas inlet \varnothing 35 |
| 2 | Liquid outlet \varnothing 16 |
| 3 | Power supply \varnothing 37 |
| 4 | Electric control board |
| 5 | Vibration dumpers |

MTE 42

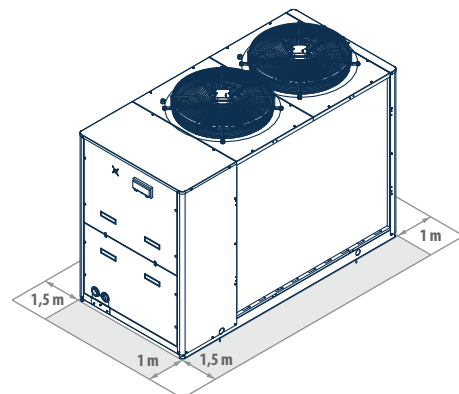
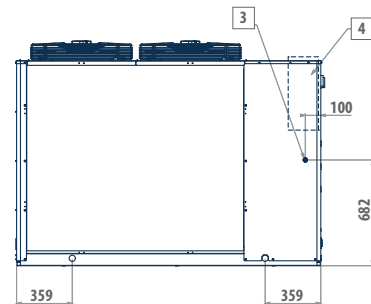
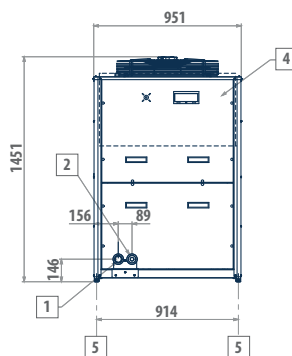
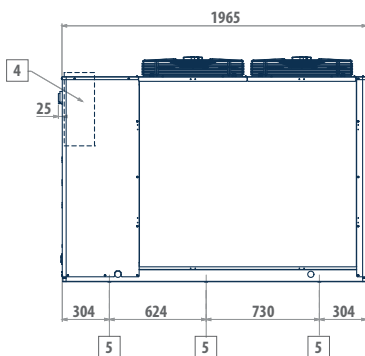

LEGEND

- | | |
|---|-------------------------------|
| 1 | Gas inlet \varnothing 42 |
| 2 | Gas outlet \varnothing 22 |
| 3 | Power supply \varnothing 37 |
| 4 | Electric control board |
| 5 | Vibration dumpers |

DIMENSIONAL DRAWINGS

MTE 53 - 82

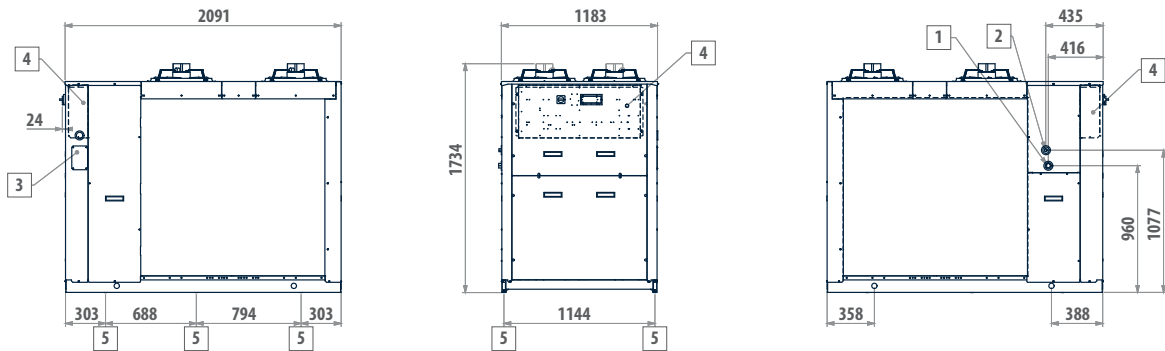

LEGEND

- | | |
|---|--------------------------------|
| 1 | Gas inlet \varnothing 35 |
| 2 | Liquid outlet \varnothing 22 |
| 3 | Power supply |
| 4 | Electric control board |
| 5 | Vibration dumpers |

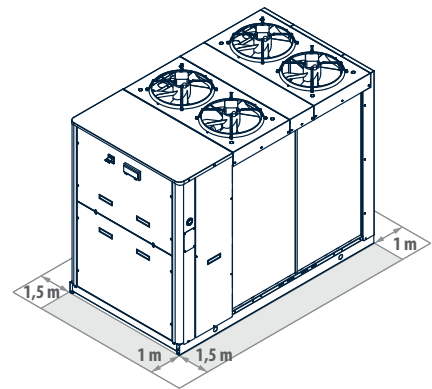

MTE 96-108

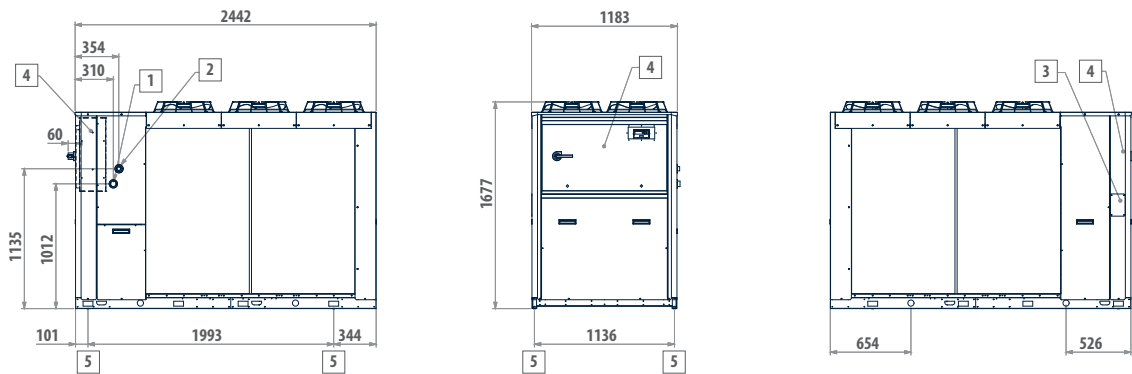

LEGEND

- | | |
|---|--------------------------------|
| 1 | Gas inlet \varnothing 45 |
| 2 | Liquid outlet \varnothing 28 |
| 3 | Power supply |
| 4 | Electric control board |
| 5 | Vibration dumpers |

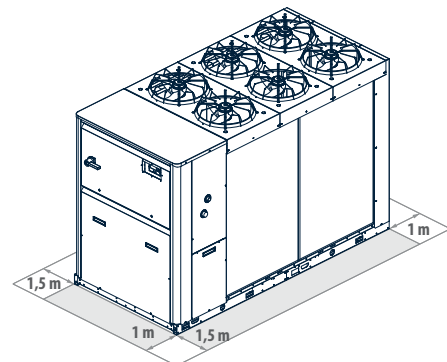

Motor-driven condensing units MTE

DIMENSIONAL DRAWINGS

MTE 129 - 163

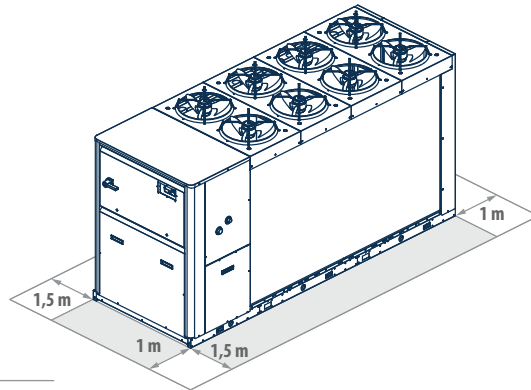
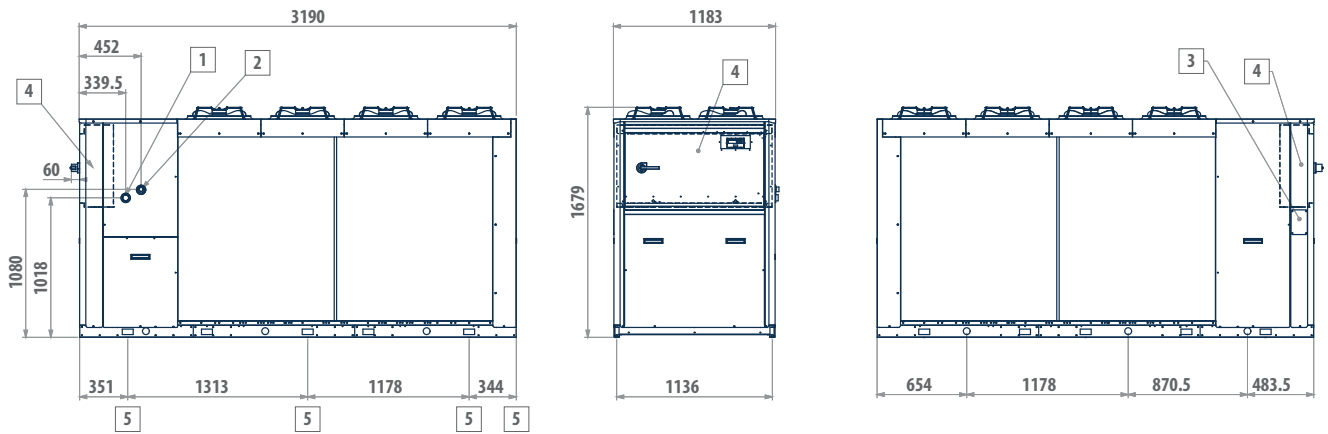

LEGEND

1	Gas inlet \varnothing 42
2	Liquid outlet \varnothing 28
3	Power supply
4	Electric control board
5	Vibration dampers

DIMENSIONAL DRAWINGS

MTE 169 - 214

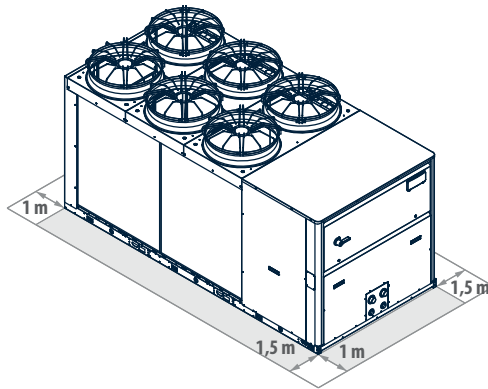
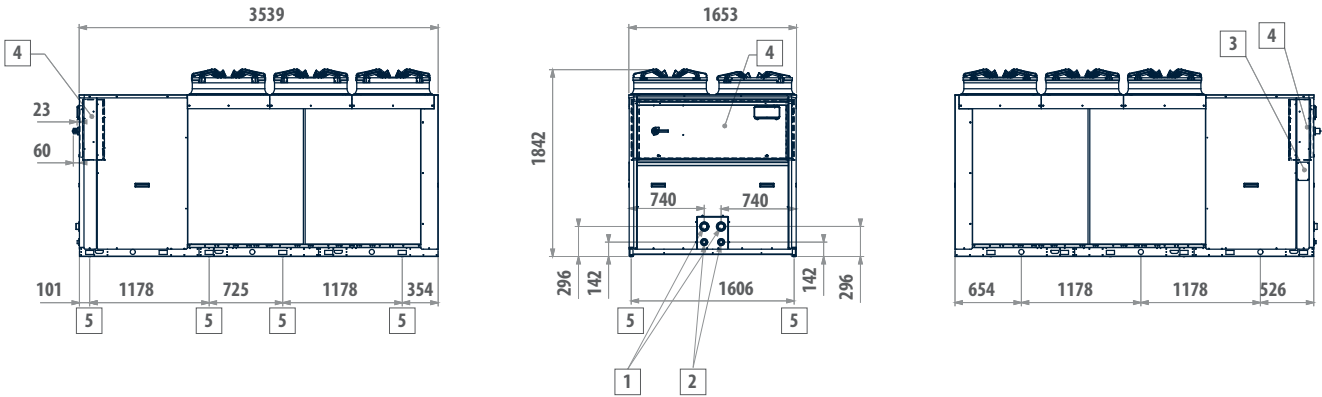

LEGEND

1	Gas inlet ø 54
2	Liquid outlet ø 28
3	Power supply
4	Electric control board
5	Vibration dampers

Indoor motor-driven evaporating units

LER 40 - 420 kW



Scroll compressor



Refrigerant R-410A



Cooling only



Split version

PLUS

- » Electronic expansion valve
- » Up to 4 compressors
- » 1 or 2 cooling circuits
- » Remote connectivity with the most common protocols
- » Compact dimensions
- » Low noise levels due to the panelling

Compact and silent machines with remote dissipation into the air

The LER range consists of 20 models with a cooling capacity range from 40 to 420 kW and is available in a standard or silenced acoustic version.

The possibility of setting up different cooling circuits in units of the same power means being able to personalise efficiency levels under full or part load conditions and the redundancy. Three different efficiency packs are available:

- 1 cooling circuit, 2 compressors
- 2 cooling circuits, 2 compressors
- 2 cooling circuits, 4 compressors

The LER units are developed in a completely enclosed version for a low noise operation making it possible to install them in non-segregated environments. They are characterized by a rounded shape contributing to an attractive appearance.

The possibility of keeping the evaporator indoors means there is no need to add glycol to the water inside the system, which brings clear benefits in terms of thermodynamic efficiency, protection against corrosion and respect for the environment. In addition, you can keep all components requiring maintenance in an easily accessible room.

In air-conditioning applications it is often requested to have heat available for heating sanitary water or controlling post-heating in air handling units where independent temperature and humidity control is required. All the cooling only units of the LER series are available on request with desuperheater for partial heat recovery; the available thermal power, which can, for example, be used to produce domestic hot water or for post-heating heat exchangers, depends on the unit's operating conditions.

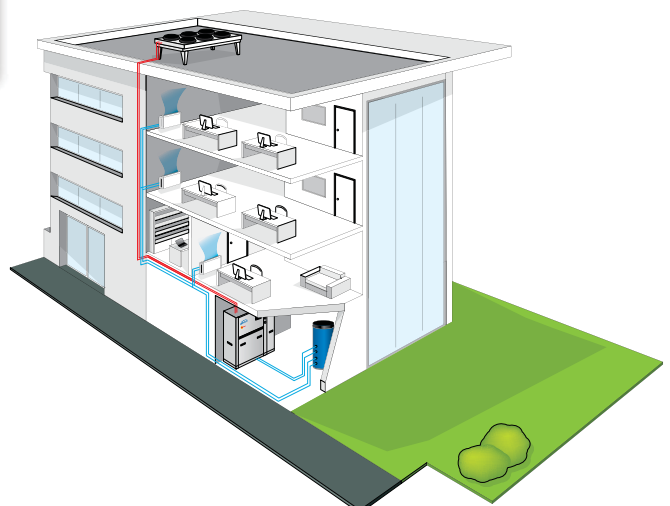

The LER units and the remote heat sink are connected with refrigerant lines whose length can exceed the conventional limits by using a specific kit for oil recovery and creating siphons distributed on the lines.

MAIN COMPONENTS

Structure

Made in galvanised steel sheet with a polyester powder coating for outdoors. The compressor compartment is completely sealed and may be accessed on 3 sides thanks to easy-to-remove panels that greatly simplify maintenance and/or inspection.

Scroll compressors

Scroll compressors are now the best solution in terms of reliability and limiting the sound power emitted. The compressors are supplied complete with motor protection against overheating, overcurrents and excessive outlet gas temperatures.

Heat exchanger

Heat exchangers with braze-welded AISI 316 austenitic stainless steel plates and connections made of AISI 316 L, characterised by a reduced carbon content to facilitate brazing.



Cooling circuit

It can be made in three different versions with the same power (Efficiency Pack), using mainly:

- R410A scroll compressors
- brazed plate heat exchangers
- electronic expansion valves



Electronic microprocessor control

It allows complete management of the unit. The electronic control system allows the set-point to be adjusted automatically according to the outdoor temperature in order to reduce consumption and broaden the working temperature range. With the advanced microprocessor control it is possible to set up LAN networks for controlling 4 units in parallel.

CONFIGURATOR

The models are completely configurable by selecting the version and the options. To the right is shown an example of configuration.

Version	Fields	1	2	3	4	5	6	7	8	9	10
LER062CS		0	B	0	0	0	1	G	0	0	0

To verify the compatibility of the options, use the selection software or the price list.

AVAILABLE VERSIONS

Cooling only versions

- LER..CS Standard execution
LER..CL Low noise execution

CONFIGURATION OPTIONS

- | | |
|---|---|
| <p>1 Power supply</p> <p>0 400 V - 3 N - 50 Hz</p> <p>2 400 V - 3 N - 50 Hz + magnetic breakers</p> <p>2 Onboard controller and expansion valve</p> <p>0 Basic + electronic expansion valve</p> <p>A Basic + mechanical expansion valve</p> <p>B Advanced + electronic expansion valve</p> <p>C Advanced + mechanical expansion valve</p> <p>3 Partial heat recovery</p> <p>0 Absent</p> <p>D Desuperheater with water pump free contact</p> <p>4 Outdoor unit air flow modulation</p> <p>0 Absent</p> <p>C Condensation control by phase-cut fans</p> <p>I Condensation control through one 0-10 V signal for each refrigerant circuit</p> <p>P Condensation control through single 0-10 V signal</p> <p>5 User water flow modulation</p> <p>0 Absent</p> <p>D 0-10V signal for water flow adjustment with $\Delta T = \text{const}$ (advanced controller required)</p> <p>T 0-10V signal for water flow adjustment with $T = \text{const}$ (advanced controller required)</p> <p>6 Remote communication</p> <p>0 Absent</p> <p>1 RS485 serial board (Carel / Modbus protocol)</p> | <p>2 LON FTT10 serial board (advanced controller required)</p> <p>3 GSM modem board (advanced controller required)</p> <p>4 BACNET IP / PCOWEB serial board + supervision software Gweb (advanced controller required)</p> <p>5 BACNET IP / PCOWEB serial board + clock board + supervision software Gweb (advanced controller required)</p> <p>7 Anti vibration shock mounts</p> <p>0 Absent</p> <p>G Rubber anti vibration shock mounts</p> <p>M Spring anti vibration shock mounts</p> <p>8 Packing</p> <p>0 Standard</p> <p>1 Wooden cage</p> <p>2 Wooden crate</p> <p>9 Remote control</p> <p>0 Absent</p> <p>1 Remote simplified user panel</p> <p>2 Remote simplified user panel for standard controller</p> <p>3 Remote simplified user panel for advanced controller</p> <p>10 Accessories for long pipes installation</p> <p>0 Absent</p> <p>1 Oil recovery kit for refrigerant pipes > 30 m</p> |
|---|---|

ACCESSORIES

A	Power factor capacitors	H	Refrigerant pressure gauges
B	Soft starter	I	Pair of couplings Victaulic
C	Service kit (advanced controller required)	L	Filter isolation valves kit (solenoid valve and isolation valve)
D	Clock board (advanced controller required)	M	Set point compensation outdoor temperature probe
E	ON/OFF status of the compressors	N	Directives reference other than "2014/68/UE - PED"
F	Remote control for step capacity limit (advanced controller required)	P	Unit lifting pipes
G	Configurable digital alarm board (advanced controller required)		

Motor-driven evaporating units LER

RATED TECHNICAL DATA OF LER MOTOR-DRIVEN EVAPORATING UNITS

LER C			41	42	51	52	61	62	71	72	81
Power supply		V-ph-Hz	400 - 3N - 50								
Cooling capacity	(1)	kW	42,2	41,6	49,9	49,9	56,7	56,7	64,8	64,8	73,9
Total power input	(1)	kW	13,3	12,7	15,7	15,7	17,5	17,5	20,1	20,1	22,4
EER	(1)		3,17	3,28	3,18	3,18	3,24	3,24	3,22	3,22	3,30
Water flow	(2)	l/h	7278	7183	8623	8623	9780	9780	11196	11196	12743
Water pressure drop	(2)	kPa	27	26	36	36	29	29	36	36	28
Maximum current absorption		A	32	30	37	37	40	40	46	46	50
Compressors / circuits			2 / 2	2 / 1	2 / 2	2 / 1	2 / 2	2 / 1	2 / 2	2 / 1	2 / 2
Sound power level	(3)	dB(A)	72	72	72	72	73	73	73	73	74
Sound power level, low-noise version	(3)	dB(A)	68	68	68	68	69	69	69	69	70
Transport / operating weight		kg	372	362	432	422	442	432	452	442	472

LER C			82	91	92	111	112	131	132	141	142
Power supply		V-ph-Hz	400 - 3N - 50								
Cooling capacity	(1)	kW	73,9	82,4	82,4	99,3	99,3	114	114	130	130
Total power input	(1)	kW	22,4	25,4	25,4	29,9	29,9	34,5	34,5	39,5	39,5
EER	(1)		3,30	3,24	3,24	3,32	3,32	3,29	3,29	3,30	3,30
Water flow	(2)	l/h	12743	14214	14214	17125	17125	19575	19575	22466	22467
Water pressure drop	(2)	kPa	28	34	34	29	29	36	36	34	34
Maximum current absorption		A	50	61	61	70	70	79	79	91	91
Compressors / circuits			2 / 1	2 / 2	2 / 1	2 / 2	2 / 1	2 / 2	2 / 1	2 / 2	2 / 1
Sound power level	(3)	dB(A)	74	76	76	76	76	77	77	77	77
Sound power level, low-noise version	(3)	dB(A)	70	72	72	72	72	73	73	73	73
Transport / operating weight		kg	462	512	492	563	553	573	563	633	618

LER C			144	161	162	164	181	182	184	204	214
Power supply		V-ph-Hz	400 - 3N - 50								
Cooling capacity	(1)	kW	131	146	146	146	171	171	166	183	196
Total power input	(1)	kW	40,1	44,5	44,5	44,7	52,1	52,1	50,7	55,2	59,8
EER	(1)		3,27	3,28	3,28	3,28	3,28	3,28	3,27	3,31	3,29
Water flow	(2)	l/h	22588	25166	25166	25262	29450	29450	28602	31487	33891
Water pressure drop	(2)	kPa	34	36	36	37	39	39	37	37	42
Maximum current absorption		A	92	102	102	100	116	116	122	131	140
Compressors / circuits			4 / 2	2 / 2	2 / 1	4 / 2	2 / 2	2 / 1	4 / 2	4 / 2	4 / 2
Sound power level	(3)	dB(A)	80	77	77	80	78	78	81	81	81
Sound power level, low-noise version	(3)	dB(A)	76	73	73	76	74	74	77	77	77
Transport / operating weight		kg	723	673	653	743	713	693	853	873	923

LER C			244	284	314	344	374	424	484
Power supply		V-ph-Hz	400 - 3N - 50						
Cooling capacity	(1)	kW	232	261	290	310	337	380	432
Total power input	(1)	kW	68,6	78,6	88,7	96,2	104	120	132
EER	(1)		3,38	3,32	3,26	3,22	3,25	3,16	3,27
Water flow	(2)	l/h	39974	44933	49885	53406	58041	65427	74392
Water pressure drop	(2)	kPa	23	29	35	40	38	40	38
Maximum current absorption		A	159	182	205	218	232	281	302
Compressors / circuits			4 / 2						
Sound power level	(3)	dB(A)	82	82	82	83	83	83	86
Sound power level, low-noise version	(3)	dB(A)	78	78	78	79	79	79	82
Transport / operating weight		kg	983	1093	1253	1293	1333	1413	1520

(1) Water temperature - user side 12°C / 7°C, condensation temperature 50°C (EN14511:2013)

(2) Water temperature - user side 12°C / 7°C, condensation temperature 50°C (14511:2013)

(3) Sound power level measured according to ISO 9614

DIMENSIONAL DRAWINGS

LER 42 - 92

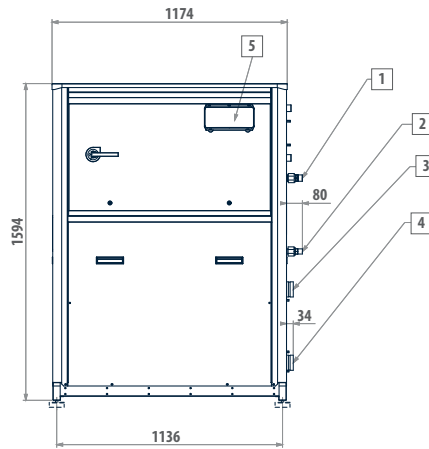
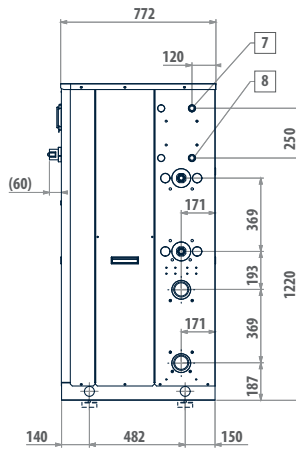

LEGEND

- 1 Air outlet, refrigerant side (ø 28)
- 2 Air intake, refrigerant side (ø 22)
- 3 User circuit inlet (Victaulic 2"½)
- 4 User circuit outlet (Victaulic 2"½)
- 5 User interface
- 6 Power supply input
- 7 Optional heat recovery water outlet (1")
- 8 Optional heat recovery water inlet (1")

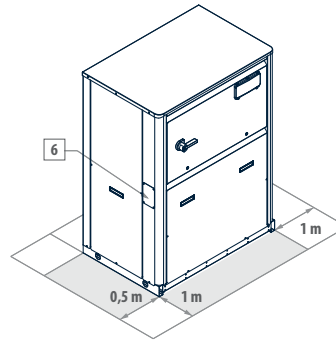

MODEL VERSION

LER 42	S-L
LER 52	S-L
LER 62	S-L
LER 72	S-L
LER 82	S-L
LER 92	S-L

LER 41 - 91

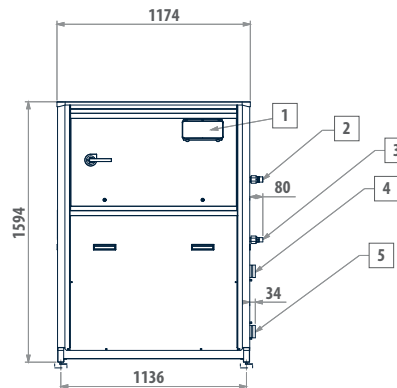
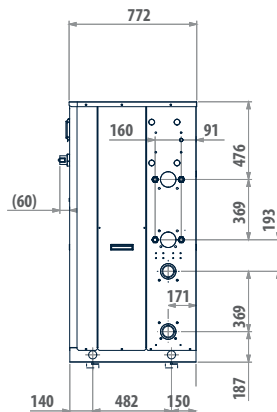

LEGEND

- 1 User interface
- 2 Air outlet, refrigerant side (ø 22)
- 3 Liquid return (ø 16)
- 4 User circuit inlet (Victaulic 2"½)
- 5 User circuit outlet (Victaulic 2"½)
- 6 Power supply input

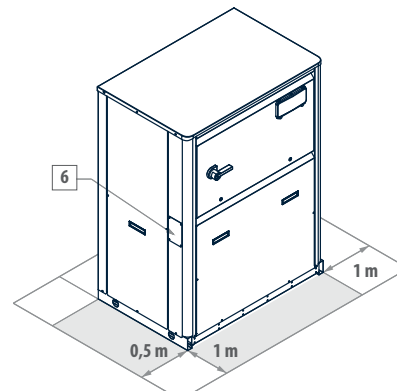

MODEL VERSION

LER 41	S-L
LER 51	S-L
LER 61	S-L
LER 71	S-L
LER 81	S-L
LER 91	S-L

Motor-driven evaporating units LER

DIMENSIONAL DRAWINGS

LER 112 - 182

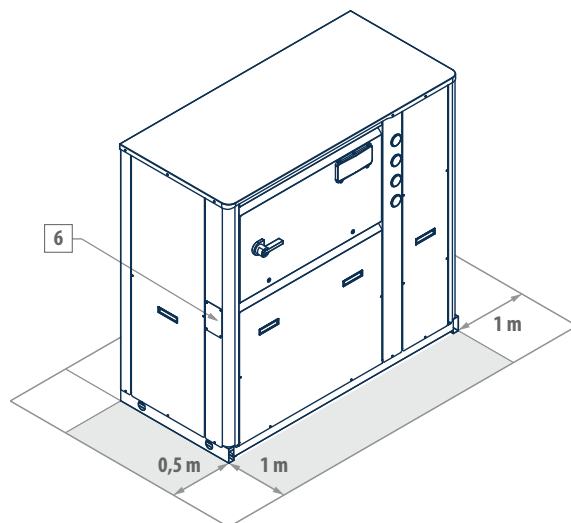
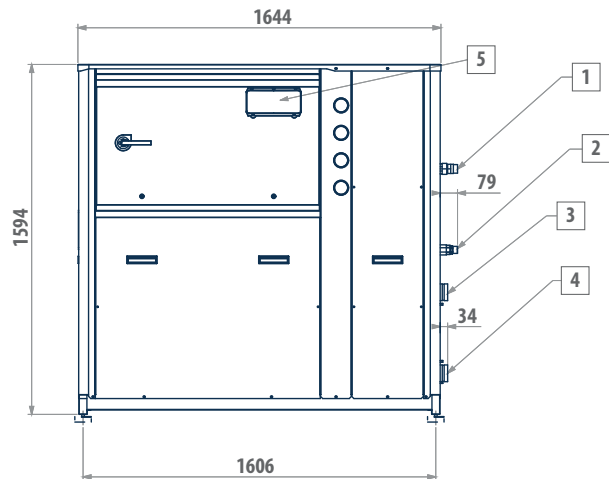
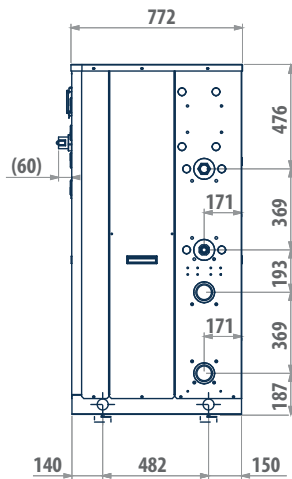

LEGEND

1	Air outlet, refrigerant side (ø 35)
2	Air intake, refrigerant side (ø 35)
3	User circuit inlet (Victaulic 2"½)
4	User circuit outlet (Victaulic 2"½)
5	User interface
6	Power supply input

MODEL VERSION

LER 112	S-L
LER 132	S-L
LER 142	S-L
LER 162	S-L
LER 182	S-L

DIMENSIONAL DRAWINGS

LER 111 - 181

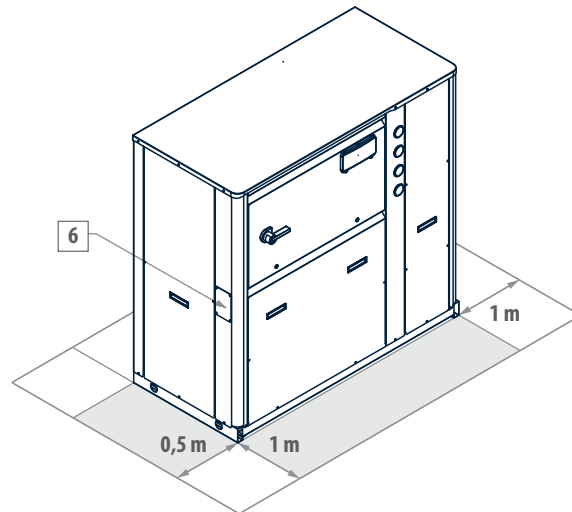
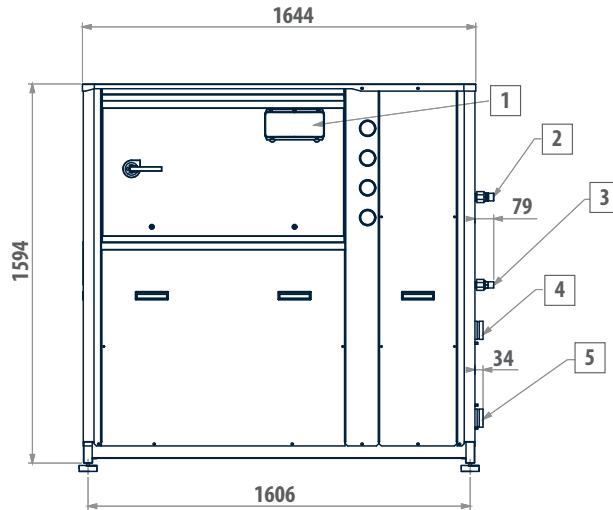
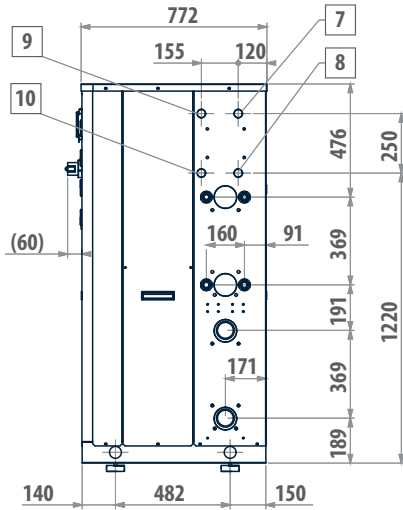

LEGEND

1	User interface
2	Air outlet, refrigerant side (ø 28)
3	Liquid return (ø 22)
4	User circuit inlet (Victaulic 2"½)
5	User circuit outlet (Victaulic 2"½)
6	Power supply input
7	Optional heat recovery water outlet (1") - circ. 2
8	Optional heat recovery water inlet (1") - circ. 2
9	Optional heat recovery water outlet (1") - circ. 1
10	Optional heat recovery water inlet (1") - circ. 1

MODEL VERSION

LER 111	S - L
LER 131	S - L
LER 141	S - L
LER 161	S - L
LER 181	S - L

Motor-driven evaporating units LER

DIMENSIONAL DRAWINGS

LER 144 - 214

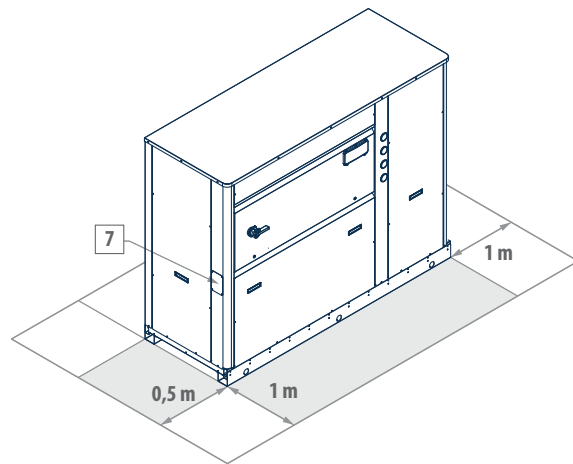
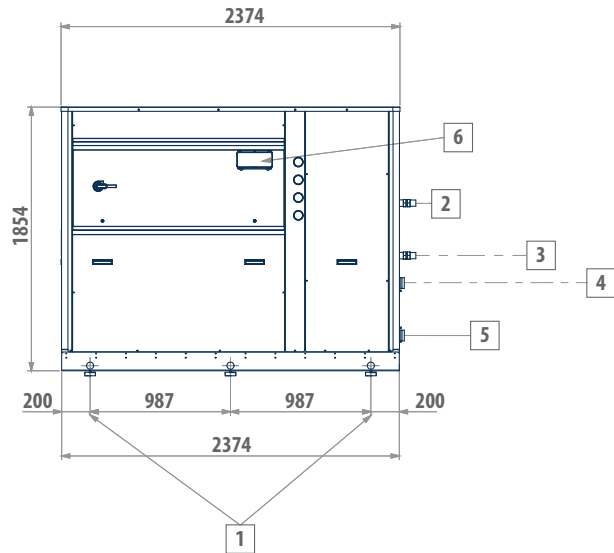
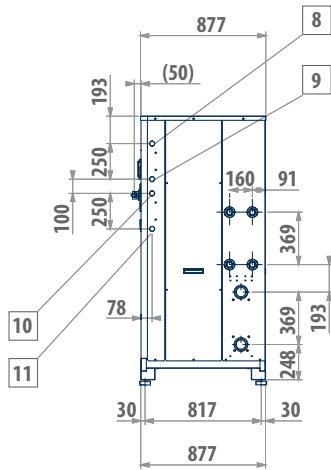

LEGEND

1	Lifting points
2	Air outlet, refrigerant side (ø 42)
3	Liquid return (ø 35)
4	User circuit inlet (Victaulic 2"½)
5	User circuit outlet (Victaulic 2"½)
6	User interface
7	Power supply input
8	Optional heat recovery water outlet (1") - circ. 1
9	Optional heat recovery water inlet (1") - circ. 1
10	Optional heat recovery water outlet (1") - circ. 2
11	Optional heat recovery water inlet (1") - circ. 2

MODEL VERSION

LER 144	S-L
LER 164	S-L
LER 184	S-L
LER 204	S-L
LER 214	S-L

DIMENSIONAL DRAWINGS

LER 244 - 484

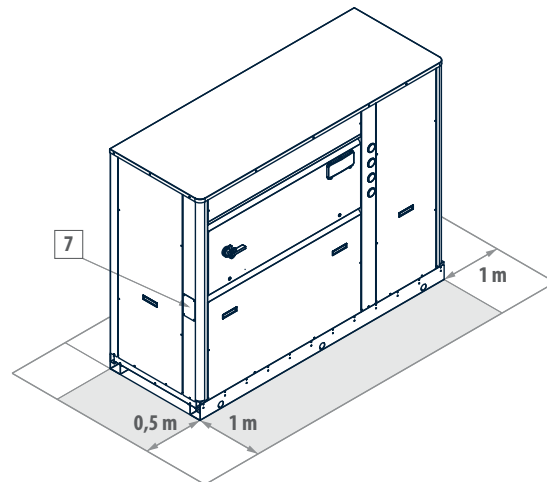
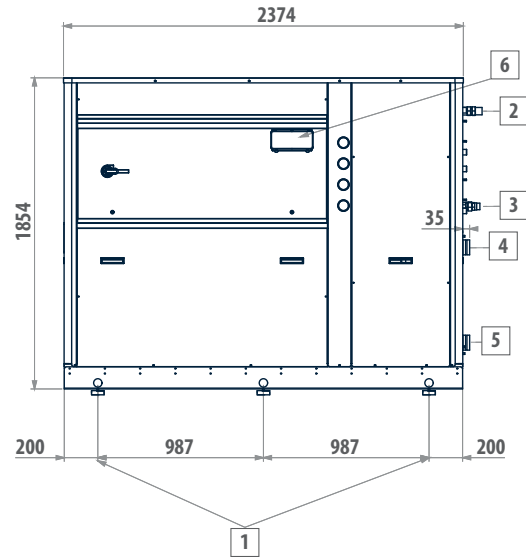
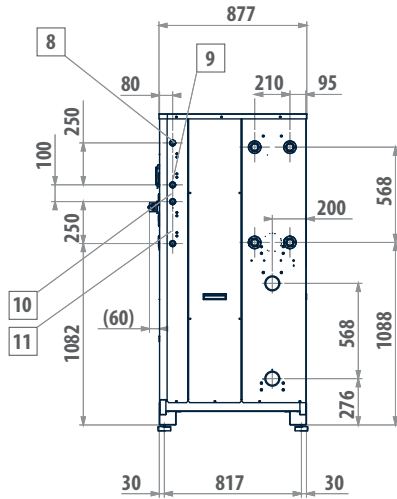

LEGEND

1	Lifting points
2	Air outlet, refrigerant side (ø 42)
3	Liquid return (ø 35)
4	User circuit inlet (Victaulic 3")
5	User circuit outlet (Victaulic 3")
6	User interface
7	Power supply input
8	Optional heat recovery water outlet (1") - circ. 1
9	Optional heat recovery water inlet (1") - circ. 1
10	Optional heat recovery water outlet (1") - circ. 2
11	Optional heat recovery water inlet (1") - circ. 2

MODEL VERSION

LER 244	S - L
LER 284	S - L
LER 314	S - L
LER 344	S - L
LER 374	S - L
LER 424	S - L
LER 484	S - L



WATER CHILLERS AND HEAT PUMPS

Introduction	p. 262
MCW	p. 264
LEW	p. 270



Water chillers and heat pumps

GEO THERMAL ENERGY

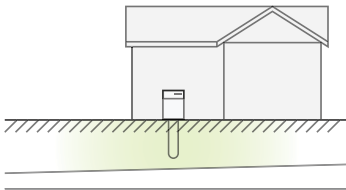

HYDROTHERMAL ENERGY

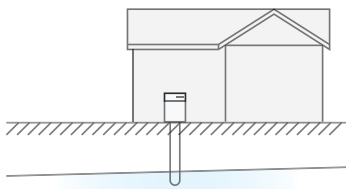

A complete offer ranging from 5 to 700 kW, which adapts to every type of source

The possibility of using water to receive condensation heat from a chilling unit or using water as an energy source for a heat pump, represents an important opportunity to achieve high seasonal and nominal energy performances. Compared to air, in fact, the temperature of the water from an aquifer, well or watercourse is characterised by significantly lower values in summer and higher values in winter and, in general, by slight variations when functioning during the different seasons. Galletti's range of MCW and LEW chillers and heat pumps have been designed to exploit this opportunity more efficiently and various versions of the units are available to better adapt to different types of installations. Water chillers are also used combined with a dry cooler, where it is not possible to install an air unit for lack of space or for the presence of structures that are not able to support its weight.



An efficiency pack for every application

To respond to the different installation requirements in the air conditioning market means being able to propose ad hoc technical solutions where the main features are optimised each time, according to the specific project.

The philosophy underlying the Efficiency Pack adopted on Galletti's range of water-cooled chillers aims to provide systems that focus on reliability and redundancy through bi-circuit solutions or part-load efficiency through tandem or trio solutions. In the first case, the continuity of the supply of power to the system is in fact guaranteed by the presence of independent circuits and continues to operate when the machine comes to a partial stop. In the second case, however, the presence of several compressors connected in parallel to the same cooling circuit allows to achieve a high degree of efficiency under part-load conditions.



High power density

The footprint represents a key feature for units installed inside equipment compartments. The design philosophy which characterises Galletti's water-water units takes this aspect into account, favouring a compact size by choosing smaller components without overlooking efficiency and reliability.

The scroll compressors and the plate heat exchangers fully comply with these criteria, while the careful positioning of the water connections to the system, helps minimising the space required and installation costs.

Versatility in every application

The different water temperatures needed to allow condensation heat to dissipate require ad hoc sizings of the plate heat exchangers involved. Whether the units use water from a well or aquifer, or whether the units are to be connected to a dry-cooler or an evaporating tower, from the range of Galletti products it is possible to choose the version that better meets the system requirements.

Versions are also available for heating purposes only which, like the reversible heat pumps, are not affected by the defrosting cycle which is typical of air-water systems.



Indoor packaged unit

MCW 5 - 39 kW



Compact single circuit units

MCW heat pumps are designed for residential and light-duty commercial environments, and in some cases for industrial applications, process industries and geothermal energy. The entire range is built with a structure and base made of galvanised sheet panelling in epoxy-polyester paint finish, RAL7035, and there is the possibility of choosing an efficient sound absorbing material which, together with the adoption of scroll type compressors, ensure that the units are exceptionally silent and compact.

With an attractive design, a small footprint, the possibility to fit the units with a hydraulic kit complete with circulation pump, expansion tank and buffer tank, means that the machines can even be installed in environments not involved in residential applications.

The design philosophy has favoured the development of units having a reduced height with water connections placed on the upper part, which reduce installation time and costs and the need for technical space.

The MCW series offers a wide range of configurations in terms of accessories available and consists of a large number of sizes, including several single-phase models, each available as a low noise version, in order to fully respond to all system requirements. Only top quality products are used for the cooling, hydraulic and electric systems guaranteeing high technical level of the MCW heat pumps in terms of efficiency, reliability and reduced noise levels.



Scroll compressor



Cooling only



Heating/
Cooling



Rotary compressor



Refrigerant
R-407C

PLUS

- » Easy installation and compact dimensions
- » Scroll compressor
- » Built-in hydronic units
- » Wide range of available accessories

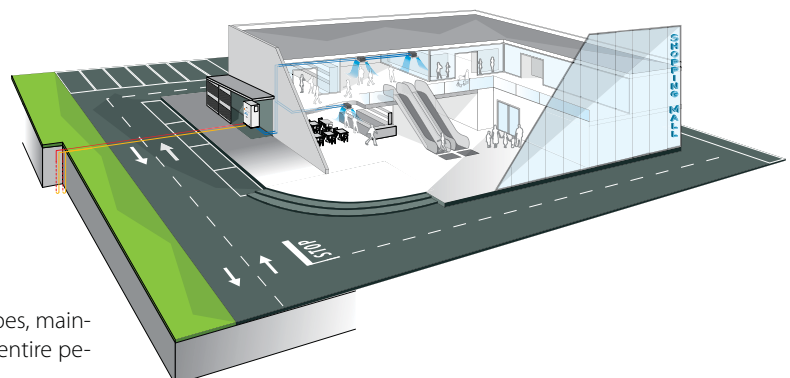

The possibility to dissipate into the aquifer or soil using probes, maintains the original performance of the MCW unit during the entire period of use.

MAIN COMPONENTS

Structure

The structure is in galvanised steel sheet, which is resistant to corrosive agents. Closed equipment compartments are accessible on three sides thanks to easily removable panels with internal sound-proofing insulation.

Compressor

Hermetic scroll compressor powered by a single or three-phase asynchronous motor. It is fixed to the base with rubber vibration dampers.

Heat exchangers

Brazed-welded plate condenser and evaporator in AISI 316 austenitic stainless steel, specifically developed to maximise heat exchange coefficients between water and refrigerant.



Microprocessor control

The microprocessor control has complete management of the MCW units and, because it is highly customisable, it allows to adapt and improve its functioning in every application.

Hydraulic kit

It consists of a centrifugal circulating pump powered by an asynchronous electric motor capable of providing a suitable available head under operating conditions. Also included are an expansion tank and an automatic filling tap.

CONFIGURATOR

The models are completely configurable by selecting the version and the options. To the right is shown an example of configuration.

Version	Fields	1	2	3	4	5	6	7	8	9	10	11	12	13	14	15
MCW039HS		1	0	C	2	0	0	0	0	M	0	G	0	0	0	0

To verify the compatibility of the options, use the selection software or the price list.

AVAILABLE VERSIONS

Versions with reversible heat pump
 MCW...HS Standard execution
 MCW...HL Low noise execution

CONFIGURATION OPTIONS

1 Refrigerant - Power supply

- 0 R407C - 230 V - 1 - 50 Hz
- 1 R407C - 400 V - 3 N - 50 Hz
- 2 R407C - 400 V - 3 - 50 Hz

2 Onboard controller and expansion valve

- 0 Basic + mechanical expansion valve

3 Source water flow modulation

- 0 Absent
- C Water flow adjustment valve onboard

4 Water pump and tank

- 0 Absent
- 1 LP pump + expansion vessel
- 2 LP pump + expansion vessel + water tank

5 Remote control / Serial communication

- 0 Absent
- 2 RS485 serial board (Carel / Modbus protocol)

6 Refrigerant pipework accessories

- 0 Absent
- M Refrigerant pressure gauges

7 Compressors options

- 0 Absent

8 Plate water condenser

- 0 Oversized water plate condenser for cooling tower/dry cooler

9 Remote control

- 0 Absent

- M Remote simplified user panel for standard controller

- S Remote simplified user panel

10 Packing

- 0 Standard
- 1 Wooden cage
- 2 Wooden crate

11 Anti vibration shock mounts

- 0 Absent
- G Rubber anti vibration shock mounts

12 Accessories

- 0 Absent

13 Dry cooler

- 0 Absent
- A Dry cooler
- B Dry cooler with condensation control (Accessory 3 = 0 needed)

14 Dry cooler 2

- 0 Absent
- 1 Standard with horizontal air flow
- 2 Standard with vertical air flow
- 3 Low noise with horizontal air flow
- 4 Low noise with vertical air flow

15 Execution

- 0 Standard
- S Special

MCW H RATED TECHNICAL DATA

MCW H		V-ph-Hz	005M	007M	010	010M	012	015	018
Power supply			230 - 1 - 50	230 - 1 - 50	400 - 3N - 50	230 - 1 - 50	400 - 3N - 50	400 - 3N - 50	400 - 3N - 50
Cooling capacity	(1)(E)	kW	5,14	6,26	8,99	8,95	10,9	13,5	15,9
Total power input	(1)(E)	kW	1,59	2,16	2,79	2,83	3,42	4,06	4,78
EER	(1)(E)		3,23	2,90	3,22	3,16	3,19	3,33	3,33
SEER	(2)(E)		2,91	2,72	3,07	3,02	3,10	3,25	3,30
Water flow user side	(1)	l/h	890	1084	1555	1548	1885	2333	2752
Water pressure drop user side	(1)(E)	kPa	24	25	22	22	25	23	24
Water flow source side	(1)	l/h	1142	1425	2001	2001	2428	2987	3518
Water pressure drop source side	(1)(E)	kPa	30	42	28	28	42	28	41
Available pressure head user side - LP pumps	(1)	kPa	92	85	78	79	148	148	140
Heating capacity	(3)(E)	kW	5,50	7,08	9,62	9,86	11,9	14,4	17,5
Total power input	(3)(E)	kW	1,78	2,36	3,06	3,13	3,70	4,43	5,16
COP	(3)(E)		3,09	3,00	3,14	3,15	3,22	3,25	3,39
SCOP	(2)(E)		4,01	3,95	4,24	4,23	4,22	4,22	4,35
Heating energy efficiency class	(4)(E)		A++						
Water flow user side	(3)	l/h	949	1219	1661	1701	2059	2487	3019
Water pressure drop user side	(3)(E)	kPa	21	32	20	21	31	20	31
Water flow source side	(3)	l/h	1108	1409	1948	1995	2448	2950	3648
Water pressure drop source side	(3)(E)	kPa	36	41	34	35	41	35	40
Available pressure head user side - LP pumps	(3)	kPa	82	75	67	67	130	124	132
Maximum current absorption		A	12	15	7	23	10	13	14
Star up current		A	47	61	46	100	50	66	74
Compressors / circuits			1 / 1						
Expansion vessel volume		dm ³	1	1	1	1	5	5	5
Buffer tank volume		dm ³	47	47	47	47	92	92	92
Sound power level	(5)(E)	dB(A)	55	55	59	59	61	61	61
Sound power level, low-noise version	(5)(E)	dB(A)	53	53	57	57	59	59	59
Transport weight unit with pump and tank		kg	141	144	147	147	173	175	182
Operating weight unit with pump and full tank		kg	176	178	181	181	235	270	289

(1) Water temperature - user side 12°C / 7°C, water temperature - dissipation side 30°C / 35°C (EN14511:2013)

(2) η efficiency values for heating and cooling are respectively calculated by the following formulas: $[\eta = SCOP / 2,5 - F(1) - F(2)]$ e $[\eta = SEER / 2,5 - F(1) - F(2)]$. For further information, please refer to the technical document "ErP 2009/125/EC DIRECTIVE" in the catalogue introducing pages, or to the EN14825:2017 regulation.

(3) Water temperature - user side 40°C / 45°C, water temperature - source side 10°C / 7°C (EN14511:2013)

(4) Seasonal energy efficiency class for LOW TEMPERATURE room heating under AVERAGE climatic conditions [EUROPEAN REGULATION No 811/2013]

(5) Sound power level measured according to ISO 9614

(E) EUROVENT certified data

MCW H RATED TECHNICAL DATA

MCW H			020	022	027	031	039
Power supply		V-ph-Hz	400 - 3N - 50				
Cooling capacity	(1)(E)	kW	18,7	19,6	24,2	27,9	34,5
Total power input	(1)(E)	kW	5,31	5,96	7,53	8,82	10,9
EER	(1)(E)		3,52	3,29	3,21	3,16	3,17
SEER	(2)(E)		3,50	3,29	3,22	3,20	3,22
Water flow user side	(1)	l/h	3236	3384	4186	4813	5952
Water pressure drop user side	(1)(E)	kPa	23	24	21	23	23
Water flow source side	(1)	l/h	4092	4341	5407	6236	7718
Water pressure drop source side	(1)(E)	kPa	35	41	35	48	48
Available pressure head user side - LP pumps	(1)	kPa	122	158	151	139	149
Heating capacity	(3)(E)	kW	19,5	21,4	26,3	30,6	37,9
Total power input	(3)(E)	kW	5,71	6,46	8,19	9,49	11,6
COP	(3)(E)		3,42	3,31	3,21	3,22	3,27
SCOP	(2)(E)		4,67	4,44	4,27	4,90	4,79
Heating energy efficiency class	(4)(E)		A+++	A++	A++	A+++	A+++
Water flow user side	(3)	l/h	3376	3695	4546	5280	6550
Water pressure drop user side	(3)(E)	kPa	25	31	25	36	36
Water flow source side	(3)	l/h	4083	4417	5353	6234	7773
Water pressure drop source side	(3)(E)	kPa	35	38	33	37	36
Available pressure head user side - LP pumps	(3)	kPa	115	127	113	89	132
Maximum current absorption		A	16	17	20	29	32
Star up current		A	101	98	130	130	135
Compressors / circuits			1 / 1				
Expansion vessel volume		dm ³	5	5	5	5	5
Buffer tank volume		dm ³	92	92	92	92	92
Sound power level	(5)(E)	dB(A)	61	62	62	65	65
Sound power level, low-noise version	(5)(E)	dB(A)	60	60	60	63	63
Transport weight unit with pump and tank		kg	225	259	271	286	297
Operating weight unit with pump and full tank		kg	292	295	307	322	348

(1) Water temperature - user side 12°C / 7°C, water temperature - dissipation side 30°C / 35°C (EN14511:2013)

(2) η efficiency values for heating and cooling are respectively calculated by the following formulas: [$\eta = SCOP / 2,5 - F(1) - F(2)$] e [$\eta = SEER / 2,5 - F(1) - F(2)$]. For further information, please refer to the technical document "ErP 2009/125/EC DIRECTIVE" in the catalogue introducing pages, or to the EN14825:2017 regulation.

(3) Water temperature - user side 40°C / 45°C, water temperature - source side 10°C / 7°C (EN14511:2013)

(4) Seasonal energy efficiency class for LOW TEMPERATURE room heating under AVERAGE climatic conditions [EUROPEAN REGULATION No 811/2013]

(5) Sound power level measured according to ISO 9614

(E) EUROVENT certified data

DIMENSIONAL DRAWINGS

MCW 005 - 010

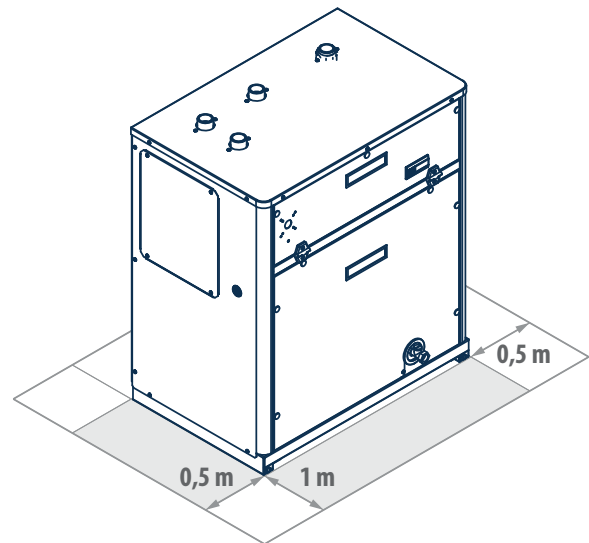
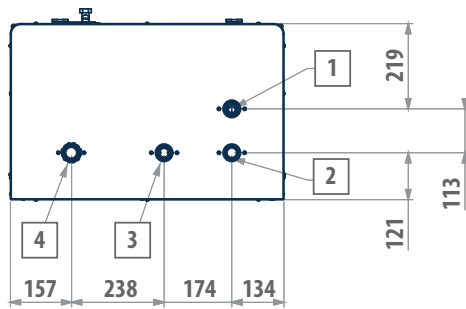
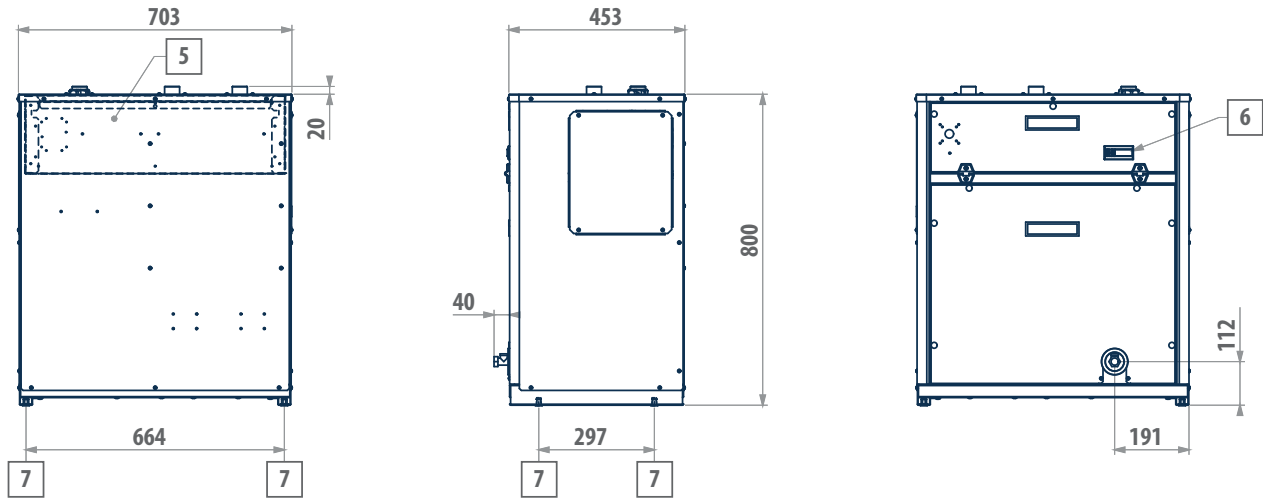

LEGEND

- | | |
|---|------------------------------------|
| 1 | Condenser water inlet (1 ¼" gas) |
| 2 | Condenser water outlet (1 ¼" gas) |
| 3 | Evaporator water inlet (1 ¼" gas) |
| 4 | Evaporator water outlet (1 ¼" gas) |
| 5 | Electric control board |
| 6 | Microprocessor control |
| 7 | Vibration dampers |

DIMENSIONAL DRAWINGS

MCW 012 - 039

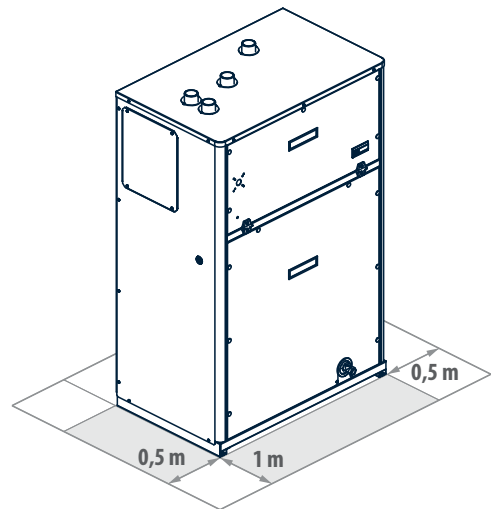
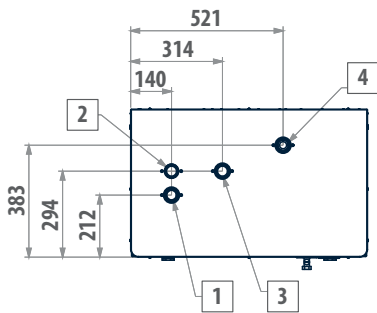
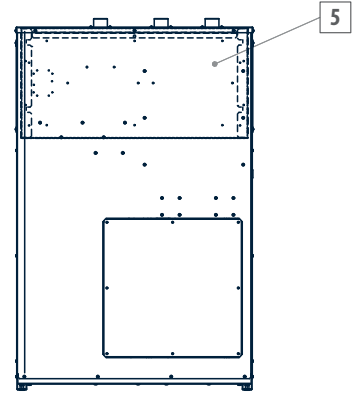
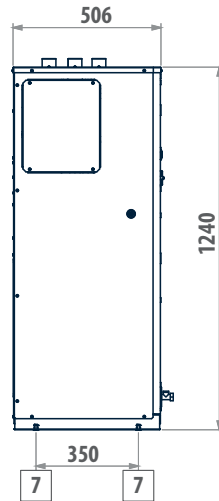
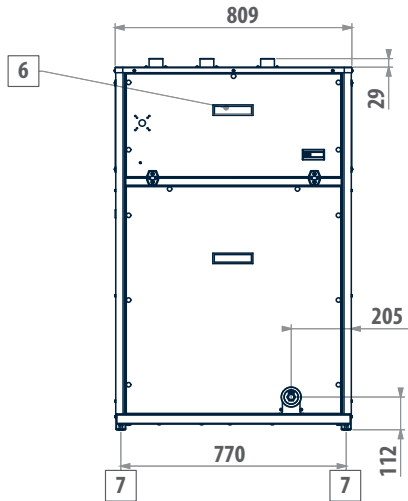

LEGEND

1	Condenser water inlet (1 ¼" gas)
2	Condenser water outlet (1 ¼" gas)
3	Evaporator water inlet (1 ¼" gas)
4	Evaporator water outlet (1 ¼" gas)
5	Electric control board
6	Microprocessor control
7	Vibration dampers

Indoor packaged unit

LEW 40 - 680 kW



PLUS

- » Electronic expansion valve
- » Up to 6 compressors
- » 1 or 2 cooling circuits
- » Remote connectivity with the most common protocols
- » Compact dimensions
- » Low noise levels thanks to complete enclosure panelling

Compact and efficient water-water units

LEW water chillers and reversible heat pumps are air conditioning or process fluid conditioning units conceived for both residential and industrial use and designed to operate 24 hours a day. They cover a wide range of heating capacities, from 40 to 680 kW, guaranteeing a high thermodynamic efficiency and broad configurability, both in terms of accessories and cooling circuits.

The LEW units are developed in a completely enclosed version for a low noise operation making it possible to install them in non-segregated environments. The use of R410A as refrigerating fluid and top quality components for the cooling, hydraulic and electric systems guarantees high technical level of the LEW units of the chillers in terms of efficiency, reliability and reduced noise levels. The LEW series is characterised by reduced footprint, high COP during the thermodynamic cycle, no external noise, reduced refrigerant charge.

The range of LEW units can be combined with geothermal probes used to dissipate in soil.

The LEW series is available as a cooling unit only, combined with a cooling tower or with water from a well or mains, a heat pump only for heating and reversible heat pumps on cooling circuit side.

The versions are in turn developed in two different acoustic systems: Standard and Low Noise.

Hydraulic modules complete with pumps on user side and dissipation side are available in a low noise version to be installed alongside the basic unit.

All units, irrespective of type of construction, are equipped with electronic expansion valves to maximise efficiency under part load conditions.

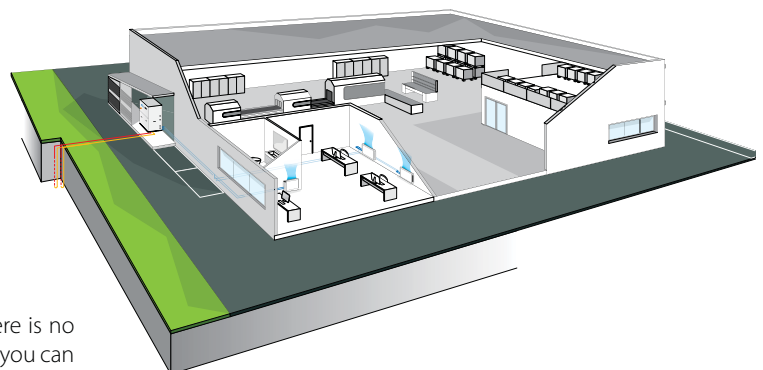

The possibility of keeping the evaporator indoors means there is no need to add glycol to the water inside the system. In addition, you can keep all components requiring maintenance in an easily accessible room.

MAIN COMPONENTS

Structure

Made in galvanised steel sheet with a polyester powder coating for outdoors.

The compressor compartment is completely sealed and may be accessed on 3 sides thanks to easy-to-remove panels that greatly simplify maintenance and/or inspection.



Compressori scroll

Scroll compressors are now the best solution in terms of reliability and limiting the sound power emitted. The compressors are supplied complete with motor protection against overheating, overcurrents and excessive outlet gas temperatures.

Heat exchangers

All units have heat exchangers with braze-welded AISI 316 austenitic stainless steel plates and connections made of AISI 316 L, characterised by a reduced carbon content to facilitate brazing.

Cooling circuit

Can be produced in two different versions using the same power size (Efficiency Pack), it mainly uses R410A scroll compressors, brazed plate heat exchangers, finned coil condenser, electronic expansion valves.



Electronic microprocessor control

It allows complete management of the unit. The electronic control system allows the setpoint to be adjusted automatically according to the outdoor temperature in order to reduce consumption and broaden the working temperature range. With the advanced microprocessor control it is possible to set up LAN networks for controlling 4 units in parallel.

CONFIGURATOR

The models are completely configurable by selecting the version and the options. To the right is shown an example of configuration.

Version	Fields	1	2	3	4	5	6	7	8	9	10
LEW132HL		2	B	0	P	0	1	G	0	0	2

To verify the compatibility of the options, use the selection software or the price list.

AVAILABLE VERSIONS

Cooling only versions

LEW...DS	Operating with dry-cooler or tower water, standard version
LEW...DL	Operating with dry-cooler or tower water, low-noise version

Versions with heat pump

LEW...HS	Reversible, standard execution
LEW...HL	Reversible, low noise execution
LEW...WS	Heating only, standard execution
LEW...WL	Heating only, low-noise execution

CONFIGURATION OPTIONS

- | | |
|---|--|
| <p>1 Refrigerant - Power supply</p> <ul style="list-style-type: none"> 0 400V - 3N - 50Hz 2 400V - 3N - 50Hz + magnetic breakers <p>2 Onboard controller and expansion valve</p> <ul style="list-style-type: none"> 0 Basic + electronic expansion valve A Basic + mechanical expansion valve B Advanced + electronic expansion valve C Advanced + mechanical expansion valve <p>3 Partial heat recovery</p> <ul style="list-style-type: none"> 0 Absent D Desuperheater with water pump free contact <p>4 Source water flow modulation</p> <ul style="list-style-type: none"> 0 Absent P 0-10V signal for condensation control <p>5 User water flow modulation</p> <ul style="list-style-type: none"> 0 Absent D 0-10V signal for water flow adjustment with $\Delta T = \text{const}$ (advanced controller required) T 0-10V signal for water flow adjustment with $T = \text{const}$ (advanced controller required) <p>6 Remote communication</p> <ul style="list-style-type: none"> 0 Absent 1 RS485 serial board (Carel / Modbus protocol) 2 LON FTT10 serial board (advanced controller required) 3 GSM modem board (advanced controller required) 4 BACNET IP / PCOWEB serial board + supervision software Gweb (advanced controller required) | <p>5 BACNET IP / PCOWEB serial board + clock board + supervision software Gweb (advanced controller required)</p> <p>7 Anti vibration shock mounts</p> <ul style="list-style-type: none"> 0 Absent G Rubber anti vibration shock mounts M Spring anti vibration shock mounts <p>8 Packing</p> <ul style="list-style-type: none"> 0 Standard 1 Wooden cage 2 Wooden crate <p>9 Remote control</p> <ul style="list-style-type: none"> 0 Absent 1 Remote simplified user panel 2 Remote simplified user panel for standard controller 3 Remote simplified user panel for advanced controller <p>10 Insulated hydraulic module</p> <ul style="list-style-type: none"> 0 Absent 1 Water pumps LP user + LP source 2 Water pumps LP user + LP inverter source (advanced controller required) 3 Water pumps LP user + HP source 4 Water pumps LP user + HP inverter source (advanced controller required) 5 Water pumps HP user + LP source 6 Water pumps HP user + LP inverter source (advanced controller required) 7 Water pumps HP user + HP source 8 Water pumps HP user + HP inverter source (advanced controller required) |
|---|--|

ACCESSORIES

A	Power factor capacitors	H	Refrigerant pressure gauges
B	Soft starter	I	Two pairs of Victaulic joints
C	Service kit (advanced controller required)	L	Filter isolation valves kit (solenoid valve and isolation valve)
D	Clock board (advanced controller required)	M	Set point compensation outdoor temperature probe
E	ON/OFF status of the compressors	N	Water temperature probes on source side (advanced controller required)
F	Remote control for step capacity limit (advanced controller required)	P	Unit lifting pipes
G	Configurable digital alarm board (advanced controller required)		

LEW D WATER CHILLERS RATED TECHNICAL DATA

LEW D			042	052	062	072	082	092	112	132
Power supply		V-ph-Hz	400 - 3N - 50							
Cooling capacity	(1)(E)	kW	47,6	56,3	64,9	73,4	84,6	94,0	114	130
Total power input	(1)(E)	kW	10,5	13,5	14,6	17,0	18,4	21,1	24,3	28,3
EER	(1)(E)		4,53	4,17	4,45	4,32	4,60	4,45	4,68	4,58
SEER	(2)(E)		5,89	5,76	6,19	6,08	5,14	6,44	5,27	5,23
Water flow user side	(1)	l/h	8219	9724	11212	12685	14604	16228	19634	22375
Water pressure drop user side	(1)	kPa	33	45	37	45	35	43	37	46
Water flow source side	(1)	l/h	9919	11888	13582	15422	17601	19645	23607	26965
Water pressure drop source side	(1)	kPa	43	60	47	60	46	57	47	61
Maximum current absorption		A	30	37	40	46	50	61	70	79
Star up current		A	111	156	158	181	178	186	240	248
Star up current with soft starter		A	73	84	97	106	119	134	178	186
Compressors / circuits			2 / 1							
Sound power level	(3)(E)	dB(A)	72	72	73	73	74	76	76	77
Sound power level, low-noise version	(3)(E)	dB(A)	68	68	69	69	70	72	72	73
Transport / operating weight		kg	362	422	432	442	462	492	553	563

LEW D			142	144	162	164	182	184	204	214
Power supply		V-ph-Hz	400 - 3N - 50							
Cooling capacity	(1)(E)	kW	149	149	167	169	196	190	209	226
Total power input	(1)(E)	kW	32,5	33,4	36,6	36,5	42,9	41,2	44,6	48,4
EER	(1)(E)		4,59	4,46	4,57	4,62	4,57	4,62	4,69	4,67
SEER	(2)(E)		5,23	6,39	5,18	5,24	5,19	5,27	5,35	5,33
Water flow user side	(1)	l/h	25727	25692	28861	29104	33845	32864	36109	39008
Water pressure drop user side	(1)	kPa	43	43	47	47	50	47	47	54
Water flow source side	(1)	l/h	31025	31136	34845	35072	40870	39630	43430	46932
Water pressure drop source side	(1)	kPa	56	57	49	50	55	51	51	60
Maximum current absorption		A	91	92	102	100	116	122	131	140
Star up current		A	291	219	302	217	368	238	288	295
Star up current with soft starter		A	226	144	237	158	285	186	224	233
Compressors / circuits			2 / 1	4 / 2	2 / 1	4 / 2	2 / 1	4 / 2	4 / 2	4 / 2
Sound power level	(3)(E)	dB(A)	77	80	77	80	78	81	81	81
Sound power level, low-noise version	(3)(E)	dB(A)	73	76	73	76	74	77	77	77
Transport / operating weight		kg	618	723	653	743	693	853	873	923

(1) Water temperature - user side 12°C / 7°C, water temperature - dissipation side 30°C / 35°C (EN14511:2013)

(2) η efficiency values for heating and cooling are respectively calculated by the following formulas: $\eta = SCOP / 2,5 - F(1) - F(2)$ e $\eta = SEER / 2,5 - F(1) - F(2)$. For further information, please refer to the technical document "ErP 2009/125/EC DIRECTIVE" in the catalogue introducing pages, or to the EN14825:2017 regulation.

(3) Sound power level measured according to ISO 9614

(E) EUROVENT certified data

LEW D WATER CHILLERS RATED TECHNICAL DATA

LEW D			243	244	283	284	314	344	374	424
Power supply		V-ph-Hz	400 - 3N - 50							
Cooling capacity	(1)(E)	kW	256	266	294	297	328	353	383	434
Total power input	(1)(E)	kW	53,7	54,4	63,8	63,7	73,4	79,4	85,4	95,3
EER	(1)(E)		4,78	4,88	4,61	4,67	4,47	4,44	4,48	4,56
SEER	(2)(E)		5,58	5,67	5,47	5,52	5,24	5,22	5,25	5,97
Water flow user side	(1)	l/h	44169	45744	50710	51237	56518	60824	66022	74859
Water pressure drop user side	(1)	kPa	28	29	35	37	44	50	47	51
Water flow source side	(1)	l/h	53105	54802	61268	61798	68600	73894	80108	90561
Water pressure drop source side	(1)	kPa	36	38	46	47	58	54	54	54
Maximum current absorption		A	153	159	174	182	205	218	232	281
Star up current		A	336	316	401	366	384	449	457	490
Star up current with soft starter		A	271	254	318	301	319	366	374	420
Compressors / circuits			3 / 1	4 / 2	3 / 1	4 / 2	4 / 2	4 / 2	4 / 2	4 / 2
Sound power level	(3)(E)	dB(A)	81	82	81	82	82	83	83	83
Sound power level, low-noise version	(3)(E)	dB(A)	77	78	77	78	78	79	79	79
Transport / operating weight		kg	953	983	1053	1093	1253	1293	1333	1413

LEW D			484	535	576	636
Power supply		V-ph-Hz	400 - 3N - 50			
Cooling capacity	(1)(E)	kW	497	549	604	653
Total power input	(1)(E)	kW	106	118	129	145
EER	(1)(E)		4,70	4,65	4,68	4,50
SEER	(2)(E)		6,13	6,07	6,04	6,02
Water flow user side	(1)	l/h	85636	94708	104180	112593
Water pressure drop user side	(1)	kPa	49	51	52	60
Water flow source side	(1)	l/h	103068	114116	125405	136309
Water pressure drop source side	(1)	kPa	59	67	69	80
Maximum current absorption		A	302	256	348	424
Star up current		A	525	551	610	621
Star up current with soft starter		A	454	495	464	565
Compressors / circuits			4 / 2	5 / 2	6 / 2	6 / 2
Sound power level	(3)(E)	dB(A)	86	89	89	90
Sound power level, low-noise version	(3)(E)	dB(A)	82	80	81	81
Transport / operating weight		kg	1520	1950	2100	2100

(1) Water temperature - user side 12°C / 7°C, water temperature - dissipation side 30°C / 35°C (EN14511:2013)

(2) η efficiency values for heating and cooling are respectively calculated by the following formulas: $[\eta = SCOP / 2,5 - F(1) - F(2)]$ e $[\eta = SEER / 2,5 - F(1) - F(2)]$. For further information, please refer to the technical document "ErP 2009/125/EC DIRECTIVE" in the catalogue introducing pages, or to the EN14825:2017 regulation.

(3) Sound power level measured according to ISO 9614

(E) EUROVENT certified data

LEW H NOT REVERSIBLE HEAT PUMPS TECHNICAL DATA

LEW H			042	052	062	072	082	092	112	132
Power supply		V-ph-Hz	400 - 3N - 50							
Cooling capacity	(1)(E)	kW	47,6	56,3	64,9	73,4	84,6	94,0	114	130
Total power input	(1)(E)	kW	10,5	13,5	14,7	17,0	18,4	21,1	24,3	28,3
EER	(1)(E)		4,53	4,17	4,41	4,32	4,60	4,45	4,68	4,58
SEER	(2)(E)		4,69	4,71	4,98	4,93	5,24	5,14	4,90	5,33
Water flow user side	(1)	l/h	8219	9724	11212	12685	14604	16228	19634	22375
Water pressure drop user side	(1)	kPa	33	44	45	43	34	42	37	45
Water flow source side	(1)	l/h	9919	11888	13582	15422	17601	19645	23607	26965
Water pressure drop source side	(1)	kPa	44	61	47	61	47	58	48	61
Heating capacity	(3)	kW	54,3	65,4	74,1	84,6	96,1	108	129	148
Total power input	(3)	kW	13,0	16,3	18,0	20,8	22,6	25,9	30,1	35,2
COP	(3)		4,18	4,01	4,12	4,07	4,25	4,15	4,29	4,19
SCOP	(2)		4,16	4,30	4,38	4,31	4,36	4,21	4,32	4,24
Heating energy efficiency class	(4)		A+++							
Water flow user side	(3)	l/h	9376	11282	12803	14611	16614	18580	22307	25508
Water pressure drop user side	(3)	kPa	40	56	42	55	42	52	43	55
Water flow source side	(3)	l/h	12146	14467	16540	18806	21561	23970	28986	33009
Water pressure drop source side	(3)	kPa	66	90	90	88	68	85	74	90
Maximum current absorption		A	30	37	40	46	50	61	70	79
Star up current		A	111	156	158	181	178	186	240	248
Star up current with soft starter		A	73	84	97	106	119	134	178	186
Compressors / circuits			2 / 1							
Sound power level	(5)(E)	dB(A)	72	72	73	73	74	76	76	77
Sound power level, low-noise version	(5)(E)	dB(A)	68	68	69	69	70	72	72	73
Transport / operating weight		kg	385	445	467	482	510	540	605	625

(1) Water temperature - user side 12°C / 7°C, water temperature - dissipation side 30°C / 35°C (EN14511:2013)

(2) η efficiency values for heating and cooling are respectively calculated by the following formulas: [$\eta = SCOP / 2,5 - F(1) - F(2)$] e [$\eta = SEER / 2,5 - F(1) - F(2)$]. For further information, please refer to the technical document "ErP 2009/125/EC DIRECTIVE" in the catalogue introducing pages, or to the EN14825:2017 regulation.

(3) Water temperature - user side 40°C / 45°C, water temperature - source side 10°C / 7°C (EN14511:2013)

(4) Seasonal energy efficiency class for MEDIUM TEMPERATURE room heating under AVERAGE climatic conditions [EUROPEAN REGULATION No 811/2013]

(5) Sound power level measured according to ISO 9614

(E) EUROVENT certified data

LEW H NOT REVERSIBLE HEAT PUMPS TECHNICAL DATA

LEW H			142	144	162	164	182	184	204	214
Power supply		V-ph-Hz	400 - 3N - 50							
Cooling capacity	(1)(E)	kW	149	149	166	167	198	193	209	228
Total power input	(1)(E)	kW	32,5	33,4	37,0	36,9	42,9	41,2	45,1	48,4
EER	(1)(E)		4,59	4,46	4,50	4,53	4,63	4,68	4,63	4,71
SEER	(2)(E)		5,33	5,16	5,22	5,25	5,36	5,45	5,41	5,50
Water flow user side	(1)	l/h	25727	25692	28730	28873	34226	33248	35970	39338
Water pressure drop user side	(1)	kPa	42	42	47	47	41	40	45	43
Water flow source side	(1)	l/h	31025	31136	34767	34889	41261	40015	43340	47280
Water pressure drop source side	(1)	kPa	57	58	63	64	56	54	63	60
Heating capacity	(3)	kW	170	171	190	191	225	218	237	258
Total power input	(3)	kW	40,0	40,7	45,3	45,6	52,4	50,7	55,9	60,1
COP	(3)		4,24	4,20	4,19	4,19	4,29	4,31	4,24	4,30
SCOP	(2)		4,32	4,34	4,28	4,28	4,34	4,34	4,29	4,33
Heating energy efficiency class	(4)		A+++							
Water flow user side	(3)	l/h	29316	29540	32846	33016	38889	37800	40982	44703
Water pressure drop user side	(3)	kPa	51	52	57	58	50	48	57	54
Water flow source side	(3)	l/h	38001	38191	42474	42688	50535	49162	53121	58132
Water pressure drop source side	(3)	kPa	86	86	94	94	84	81	92	88
Maximum current absorption		A	91	92	102	100	116	122	131	140
Star up current		A	291	219	302	217	368	238	288	295
Star up current with soft starter		A	226	144	237	158	285	186	224	233
Compressors / circuits			2 / 1	4 / 2	2 / 1	4 / 2	2 / 1	4 / 2	4 / 2	4 / 2
Sound power level	(5)(E)	dB(A)	77	80	77	80	78	81	81	81
Sound power level, low-noise version	(5)(E)	dB(A)	73	76	73	76	74	77	77	77
Transport / operating weight		kg	685	830	740	865	780	985	1110	1065

(1) Water temperature - user side 12°C / 7°C, water temperature - dissipation side 30°C / 35°C (EN14511:2013)

(2) η efficiency values for heating and cooling are respectively calculated by the following formulas: $\eta = SCOP / 2,5 - F(1) - F(2)$ e $\eta = SEER / 2,5 - F(1) - F(2)$. For further information, please refer to the technical document "ErP 2009/125/EC DIRECTIVE" in the catalogue introducing pages, or to the EN14825:2017 regulation.

(3) Water temperature - user side 40°C / 45°C, water temperature - source side 10°C / 7°C (EN14511:2013)

(4) Seasonal energy efficiency class for MEDIUM TEMPERATURE room heating under AVERAGE climatic conditions [EUROPEAN REGULATION No 811/2013]

(5) Sound power level measured according to ISO 9614

(E) EUROVENT certified data

LEW H NOT REVERSIBLE HEAT PUMPS TECHNICAL DATA

LEW H			243	244	283	284	314	344	374	424
Power supply		V-ph-Hz	400 - 3N - 50							
Cooling capacity	(1)(E)	kW	256	266	294	298	328	359	390	445
Total power input	(1)(E)	kW	54,5	54,4	63,8	63,7	73,3	79,3	85,4	95,0
EER	(1)(E)		4,70	4,88	4,61	4,67	4,47	4,52	4,56	4,68
SEER	(2)(E)		5,59	5,74	5,54	5,62	5,34	5,42	5,45	5,61
Water flow user side	(1)	l/h	44169	45744	50710	51237	56518	61829	67117	76633
Water pressure drop user side	(1)	kPa	46	30	35	36	43	42	41	42
Water flow source side	(1)	l/h	53105	54802	61268	61798	68600	74910	81217	92312
Water pressure drop source side	(1)	kPa	63	37	46	48	58	56	56	58
Heating capacity	(3)	kW	290	299	334	338	376	409	444	505
Total power input	(3)	kW	66,9	67,9	77,9	78,7	89,8	97,1	104	120
COP	(3)		4,34	4,41	4,29	4,30	4,19	4,21	4,25	4,20
SCOP	(2)		4,43	4,43	4,41	4,36	4,32	4,33	4,34	4,20
Heating energy efficiency class	(4)		A+++							
Water flow user side	(3)	l/h	50201	51848	57875	58631	65061	70840	76847	87416
Water pressure drop user side	(3)	kPa	57	33	41	43	53	51	51	52
Water flow source side	(3)	l/h	65483	67620	75020	76063	83902	91484	99445	112768
Water pressure drop source side	(3)	kPa	93	60	71	73	88	85	84	85
Maximum current absorption		A	153	159	174	182	205	218	232	281
Star up current		A	336	316	401	366	384	449	457	490
Star up current with soft starter		A	271	254	318	301	319	366	374	420
Compressors / circuits			3 / 1	4 / 2	3 / 1	4 / 2	4 / 2	4 / 2	4 / 2	4 / 2
Sound power level	(5)(E)	dB(A)	81	82	81	82	82	83	83	83
Sound power level, low-noise version	(5)(E)	dB(A)	77	78	77	78	78	79	79	79
Transport / operating weight		kg	1120	1270	1180	1340	1420	1470	1540	1650

(1) Water temperature - user side 12°C / 7°C, water temperature - dissipation side 30°C / 35°C (EN14511:2013)

(2) η efficiency values for heating and cooling are respectively calculated by the following formulas: $[\eta = SCOP / 2,5 - F(1) - F(2)] e [\eta = SEER / 2,5 - F(1) - F(2)]$. For further information, please refer to the technical document "ErP 2009/125/EC DIRECTIVE" in the catalogue introducing pages, or to the EN14825:2017 regulation.

(3) Water temperature - user side 40°C / 45°C, water temperature - source side 10°C / 7°C (EN14511:2013)

(4) Seasonal energy efficiency class for MEDIUM TEMPERATURE room heating under AVERAGE climatic conditions [EUROPEAN REGULATION No 811/2013]

(5) Sound power level measured according to ISO 9614

(E) EUROVENT certified data

LEW H NOT REVERSIBLE HEAT PUMPS TECHNICAL DATA

LEW H			484	535	576	636
Power supply		V-ph-Hz	400 - 3N - 50			
Cooling capacity	(1)(E)	kW	505	549	604	653
Total power input	(1)(E)	kW	106	118	129	145
EER	(1)(E)		4,77	4,65	4,68	4,50
SEER	(2)(E)		5,72	6,07	6,04	6,02
Water flow user side	(1)	l/h	86981	94708	104180	112593
Water pressure drop user side	(1)	kPa	43	51	52	60
Water flow source side	(1)	l/h	104466	114116	125405	136309
Water pressure drop source side	(1)	kPa	60	67	69	80
Heating capacity	(3)	kW	569	625	689	748
Total power input	(3)	kW	132	149	163	184
COP	(3)		4,30	4,20	4,23	4,07
SCOP	(2)		4,29	4,20	4,41	4,17
Heating energy efficiency class	(4)		A+++			
Water flow user side	(3)	l/h	98452	108166	119238	129453
Water pressure drop user side	(3)	kPa	54	61	63	73
Water flow source side	(3)	l/h	127813	139799	154418	166033
Water pressure drop source side	(3)	kPa	86	103	107	121
Maximum current absorption		A	302	353	348	424
Star up current		A	525	551	610	621
Star up current with soft starter		A	454	495	464	565
Compressors / circuits			4 / 2	5 / 2	6 / 2	6 / 2
Sound power level	(5)(E)	dB(A)	86	89	89	90
Sound power level, low-noise version	(5)(E)	dB(A)	82	80	81	81
Transport / operating weight		kg	1710	2150	2300	2300

(1) Water temperature - user side 12°C / 7°C, water temperature - dissipation side 30°C / 35°C (EN14511:2013)

(2) η efficiency values for heating and cooling are respectively calculated by the following formulas: [$\eta = SCOP / 2,5 - F(1) - F(2)$] e [$\eta = SEER / 2,5 - F(1) - F(2)$]. For further information, please refer to the technical document "ErP 2009/125/EC DIRECTIVE" in the catalogue introducing pages, or to the EN14825:2017 regulation.

(3) Water temperature - user side 40°C / 45°C, water temperature - source side 10°C / 7°C (EN14511:2013)

(4) Seasonal energy efficiency class for MEDIUM TEMPERATURE room heating under AVERAGE climatic conditions [EUROPEAN REGULATION No 811/2013]

(5) Sound power level measured according to ISO 9614

(E) EUROVENT certified data

LEW W NOT REVERSIBLE HEAT PUMPS TECHNICAL DATA

LEW W			041	042	051	052	061	062	071	072
Power supply		V-ph-Hz	400 - 3N - 50							
Heating capacity	(1)	kW	55,5	54,3	65,3	65,4	74,0	74,1	84,5	84,6
Total power input	(1)	kW	13,6	13,0	16,4	16,3	17,9	18,0	20,8	20,8
COP	(1)		4,08	4,18	3,98	4,01	4,13	4,12	4,06	4,07
SCOP	(2)		4,10	4,16	4,08	4,30	4,16	4,38	4,07	4,31
Heating energy efficiency class	(3)		A+++							
Water flow user side	(1)	l/h	9578	9376	11270	11282	12791	12803	14596	14611
Water pressure drop user side	(1)	kPa	42	40	56	56	42	42	55	55
Water flow source side	(1)	l/h	12314	12146	14444	14467	16521	16540	18775	18806
Water pressure drop source side	(1)	kPa	67	66	90	90	90	90	88	88
Maximum current absorption		A	32	30	37	37	40	40	46	46
Star up current		A	113	111	156	156	158	158	181	181
Star up current with soft starter		A	81	73	84	84	97	97	106	106
Compressors / circuits			2 / 2	2 / 1	2 / 2	2 / 1	2 / 2	2 / 1	2 / 2	2 / 1
Sound power level	(4)	dB(A)	72	72	72	72	73	73	73	73
Sound power level, low-noise version	(4)	dB(A)	68	68	68	68	69	69	69	69
Transport / operating weight		kg	415	385	475	445	502	467	512	482

LEW W			081	082	091	092	111	112	131	132
Power supply		V-ph-Hz	400 - 3N - 50							
Heating capacity	(1)	kW	96,1	96,1	108	108	129	129	148	148
Total power input	(1)	kW	22,6	22,6	25,9	25,9	30,1	30,1	35,2	35,2
COP	(1)		4,25	4,25	4,15	4,15	4,28	4,29	4,19	4,19
SCOP	(2)		4,13	4,36	3,97	4,21	4,08	4,32	4,01	4,24
Heating energy efficiency class	(3)		A+++							
Water flow user side	(1)	l/h	16607	16614	18576	18580	22295	22307	25511	25508
Water pressure drop user side	(1)	kPa	42	42	52	52	43	43	55	55
Water flow source side	(1)	l/h	21552	21561	23972	23970	28958	28986	33026	33009
Water pressure drop source side	(1)	kPa	68	68	85	85	74	74	90	90
Maximum current absorption		A	50	50	61	61	70	70	79	79
Star up current		A	178	178	186	186	240	240	248	248
Star up current with soft starter		A	119	119	134	134	178	178	186	186
Compressors / circuits			2 / 2	2 / 1	2 / 2	2 / 1	2 / 2	2 / 1	2 / 2	2 / 1
Sound power level	(4)	dB(A)	74	74	76	76	76	76	77	77
Sound power level, low-noise version	(4)	dB(A)	70	70	72	72	72	72	73	73
Transport / operating weight		kg	530	510	575	540	645	605	660	625

(1) Water temperature - user side 40°C / 45°C, water temperature - source side 10°C / 7°C (EN14511:2013)

(2) η efficiency values for heating and cooling are respectively calculated by the following formulas: $\eta = SCOP / 2,5 - F(1) - F(2)$ e $\eta = SEER / 2,5 - F(1) - F(2)$. For further information, please refer to the technical document "ErP 2009/125/EC DIRECTIVE" in the catalogue introducing pages, or to the EN14825:2017 regulation.

(3) Seasonal energy efficiency class for MEDIUM TEMPERATURE room heating under AVERAGE climatic conditions [EUROPEAN REGULATION No 811/2013]

(4) Sound power level measured according to ISO 9614

LEW W NOT REVERSIBLE HEAT PUMPS TECHNICAL DATA

LEW W			141	142	144	161	162	164	181	182
Power supply		V-ph-Hz	400 - 3N - 50							
Heating capacity	(1)	kW	170	170	171	190	190	191	225	225
Total power input	(1)	kW	40,0	40,0	40,7	45,3	45,3	45,6	52,4	52,4
COP	(1)		4,24	4,24	4,20	4,19	4,19	4,19	4,29	4,29
SCOP	(2)		4,07	4,32	4,34	4,04	4,28	4,28	4,30	4,34
Heating energy efficiency class	(3)		A+++							
Water flow user side	(1)	l/h	29344	29316	29540	32830	32846	33016	38942	38889
Water pressure drop user side	(1)	kPa	51	51	52	57	57	58	51	50
Water flow source side	(1)	l/h	38059	38001	38191	42442	42474	42688	50617	50535
Water pressure drop source side	(1)	kPa	86	86	86	94	94	94	84	84
Maximum current absorption		A	91	91	92	102	102	100	116	116
Star up current		A	291	291	219	302	302	217	368	368
Star up current with soft starter		A	226	226	144	237	237	158	285	285
Compressors / circuits			2 / 2	2 / 1	4 / 2	2 / 2	2 / 1	4 / 2	2 / 2	2 / 1
Sound power level	(4)	dB(A)	77	77	80	77	77	80	78	78
Sound power level, low-noise version	(4)	dB(A)	73	73	76	73	73	76	74	74
Transport / operating weight		kg	720	685	830	775	740	865	825	780

LEW W			184	204	214	243	244	283	284	314
Power supply		V-ph-Hz	400 - 3N - 50							
Heating capacity	(1)	kW	218	237	258	290	299	334	338	376
Total power input	(1)	kW	50,7	55,9	60,1	66,9	67,9	77,9	78,7	89,8
COP	(1)		4,31	4,24	4,30	4,34	4,41	4,29	4,30	4,19
SCOP	(2)		4,34	4,29	4,33	4,43	4,43	4,41	4,36	4,32
Heating energy efficiency class	(3)		A+++							
Water flow user side	(1)	l/h	37800	40982	44703	50201	51848	57875	58631	65061
Water pressure drop user side	(1)	kPa	48	57	54	57	33	41	43	53
Water flow source side	(1)	l/h	49162	53121	58132	65483	67620	75020	76063	83902
Water pressure drop source side	(1)	kPa	81	92	88	93	60	71	73	88
Maximum current absorption		A	122	131	140	153	159	174	182	205
Star up current		A	238	288	295	336	316	401	366	384
Star up current with soft starter		A	186	224	233	271	254	318	301	319
Compressors / circuits			4 / 2	4 / 2	4 / 2	3 / 1	4 / 2	3 / 1	4 / 2	4 / 2
Sound power level	(4)	dB(A)	81	81	81	81	82	81	82	82
Sound power level, low-noise version	(4)	dB(A)	77	77	77	77	78	77	78	78
Transport / operating weight		kg	985	1110	1065	1120	1270	1180	1340	1420

(1) Water temperature - user side 40°C / 45°C, water temperature - source side 10°C / 7°C (EN14511:2013)

(2) η efficiency values for heating and cooling are respectively calculated by the following formulas: $[\eta = SCOP / 2,5 - F(1) - F(2)]$ e $[\eta = SEER / 2,5 - F(1) - F(2)]$. For further information, please refer to the technical document "ErP 2009/125/EC DIRECTIVE" in the catalogue introducing pages, or to the EN14825:2017 regulation.

(3) Seasonal energy efficiency class for MEDIUM TEMPERATURE room heating under AVERAGE climatic conditions [EUROPEAN REGULATION No 811/2013]

(4) Sound power level measured according to ISO 9614

LEW W NOT REVERSIBLE HEAT PUMPS TECHNICAL DATA

LEW W			344	374	424	484	535	576	636
Power supply		V-ph-Hz	400 - 3N - 50						
Heating capacity	(1)	kW	409	444	505	569	625	689	748
Total power input	(1)	kW	97,1	104	120	132	149	163	184
COP	(1)		4,21	4,25	4,20	4,30	4,20	4,23	4,07
SCOP	(2)		4,33	4,34	4,20	4,29	4,20	4,41	4,17
Heating energy efficiency class	(3)		A+++						
Water flow user side	(1)	l/h	70840	76847	87416	98452	108166	119238	129453
Water pressure drop user side	(1)	kPa	51	51	52	54	61	63	73
Water flow source side	(1)	l/h	91484	99445	112768	127813	139799	154418	166033
Water pressure drop source side	(1)	kPa	85	84	85	86	103	107	121
Maximum current absorption		A	218	232	281	302	353	348	424
Star up current		A	449	457	490	525	551	610	621
Star up current with soft starter		A	366	374	420	454	495	464	565
Compressors / circuits			4 / 2	4 / 2	4 / 2	4 / 2	5 / 2	6 / 2	6 / 2
Sound power level	(4)	dB(A)	83	83	83	86	89	89	90
Sound power level, low-noise version	(4)	dB(A)	79	79	79	82	80	81	81
Transport / operating weight		kg	1470	1540	1650	1710	2150	2300	2300

(1) Water temperature - user side 40°C / 45°C, water temperature - source side 10°C / 7°C (EN14511:2013)

(2) η efficiency values for heating and cooling are respectively calculated by the following formulas: $\eta = SCOP / 2,5 - F(1) - F(2)$ e $\eta = SEER / 2,5 - F(1) - F(2)$. For further information, please refer to the technical document "ErP 2009/125/EC DIRECTIVE" in the catalogue introducing pages, or to the EN14825:2017 regulation.

(3) Seasonal energy efficiency class for MEDIUM TEMPERATURE room heating under AVERAGE climatic conditions [EUROPEAN REGULATION No 811/2013]

(4) Sound power level measured according to ISO 9614

DIMENSIONAL DRAWINGS

LEW 042 - 092

LEGEND VERSIONS C - D - H

1	Recovery side - inlet (M 1" gas)
2	Recovery side - outlet (M 1" gas)
3	User interface
4	Dissipation side - outlet (Victaulic 2 ½")
5	Dissipation side - inlet (Victaulic 2 ½")
6	User side - inlet (Victaulic 2 ½")
7	User side - outlet (Victaulic 2 ½")
8	Power supply input

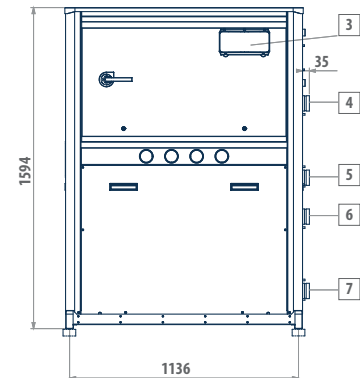
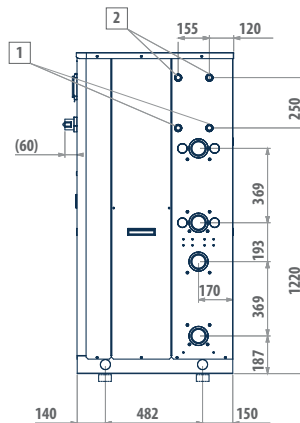

LEGEND VERSIONS W

1	Recovery side - inlet (M 1" gas)
2	Recovery side - outlet (M 1" gas)
3	User interface
4	User side - outlet (Victaulic 2 ½")
5	User side - inlet (Victaulic 2 ½")
6	Dissipation side - inlet (Victaulic 2 ½")
7	Dissipation side - outlet (Victaulic 2 ½")
8	Power supply input

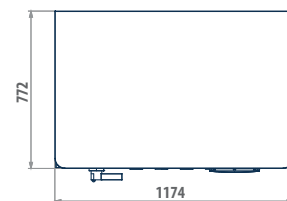
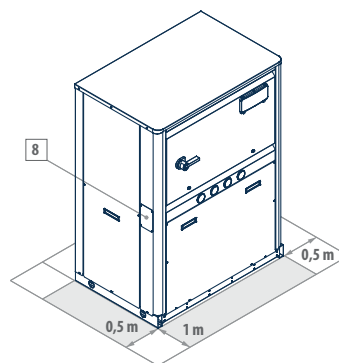

DIMENSIONAL DRAWINGS

LEW 112 - 182

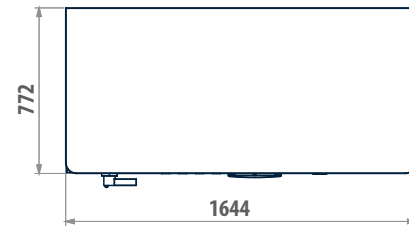
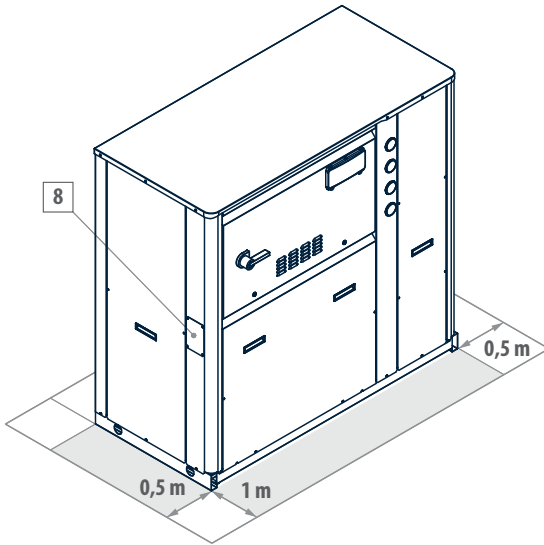
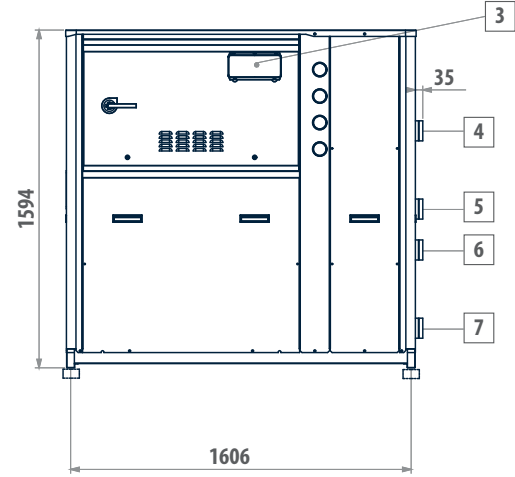
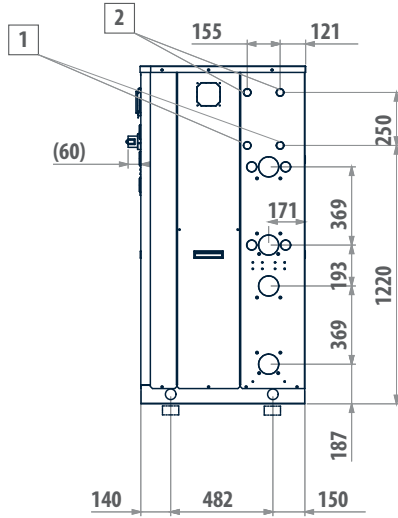

LEGEND VERSIONS C - D - H

1	Recovery side - inlet (M 1" gas)
2	Recovery side - outlet (M 1" gas)
3	User interface
4	Dissipation side - outlet (Victaulic 2 ½")
5	Dissipation side - inlet (Victaulic 2 ½")
6	User side - inlet (Victaulic 2 ½")
7	User side - outlet (Victaulic 2 ½")
8	Power supply input

LEGEND VERSIONS W

1	Recovery side - inlet (M 1" gas)
2	Recovery side - outlet (M 1" gas)
3	User interface
4	User side - outlet (Victaulic 2 ½")
5	User side - inlet (Victaulic 2 ½")
6	Dissipation side - inlet (Victaulic 2 ½")
7	Dissipation side - outlet (Victaulic 2 ½")
8	Power supply input

MODEL VERSION

LEW 112	C - D - H - W
LEW 132	C - D - H - W
LEW 142	C - D - H - W
LEW 182	C - D - H - W

DIMENSIONAL DRAWINGS

LEW 144 - 244

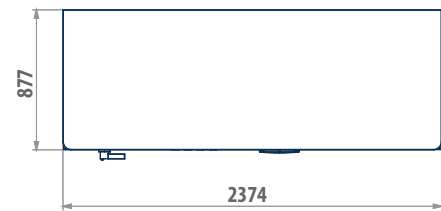
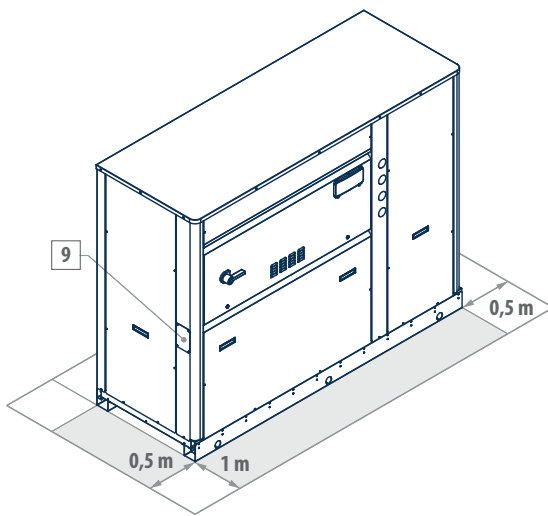
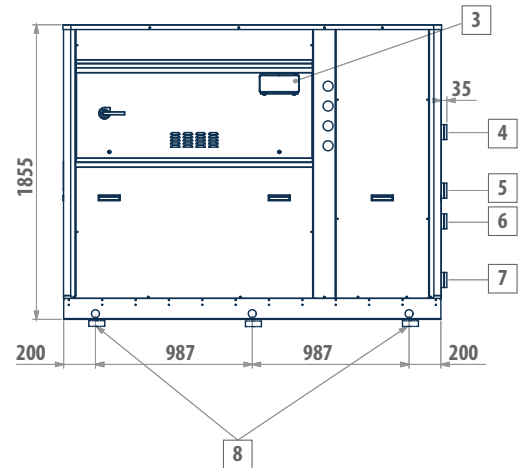
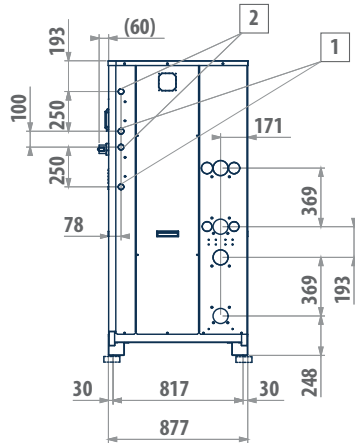

LEGEND VERSIONS C - D - H

1	Recovery side - inlet (M 1" gas)
2	Recovery side - outlet (M 1" gas)
3	User interface
4	Dissipation side - outlet (Victaulic 2 1/2")
5	Dissipation side - inlet (Victaulic 2 1/2")
6	User side - inlet (Victaulic 2 1/2")
7	User side - outlet (Victaulic 2 1/2")
8	Power supply input

LEGEND VERSIONS W

1	Recovery side - inlet (M 1" gas)
2	Recovery side - outlet (M 1" gas)
3	User interface
4	User side - outlet (Victaulic 2 1/2")
5	User side - inlet (Victaulic 2 1/2")
6	Dissipation side - inlet (Victaulic 2 1/2")
7	Dissipation side - outlet (Victaulic 2 1/2")
8	Power supply input

MODEL VERSION

LEW 144	C - D - H - W
LEW 164	C - D - H - W
LEW 184	C - D - H - W
LEW 204	C - D - H - W
LEW 214	C - D - H - W
LEW 243	C
LEW 244	C

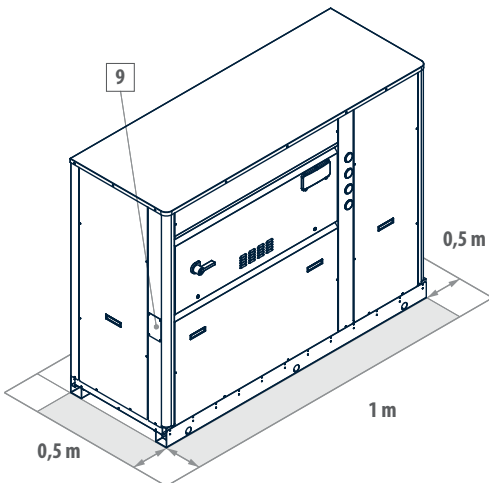
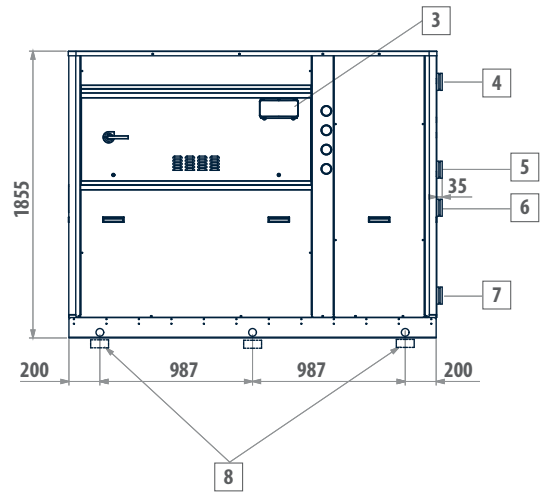
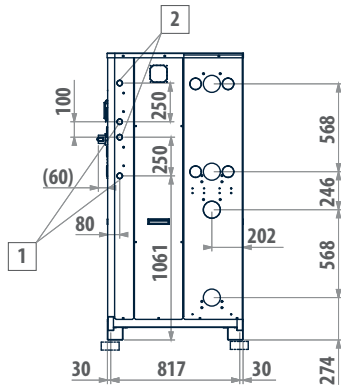
DIMENSIONAL DRAWINGS
LEW 243 - 484

LEGEND VERSIONS D - H

1	Recovery side - inlet (M 1" gas)
2	Recovery side - outlet (M 1" gas)
3	User interface
4	Dissipation side - outlet (Victaulic 3")
5	Dissipation side - inlet (Victaulic 3")
6	User side - inlet (Victaulic 3")
7	User side - outlet (Victaulic 3")
8	Power supply input

LEGEND VERSIONS W

1	Recovery side - inlet (M 1" gas)
2	Recovery side - outlet (M 1" gas)
3	User interface
4	User side - outlet (Victaulic 3")
5	User side - inlet (Victaulic 3")
6	Dissipation side - inlet (Victaulic 3")
7	Dissipation side - outlet (Victaulic 3")
8	Power supply input

MODEL VERSION

LEW 243	D - H - W
LEW 244	D - H - W
LEW 283	D - H - W
LEW 284	D - H - W
LEW 314	D - H - W
LEW 344	D - H - W
LEW 374	D - H - W
LEW 424	D - H - W
LEW 484	D - H - W

DIMENSIONAL DRAWINGS

LEW 283 - 484

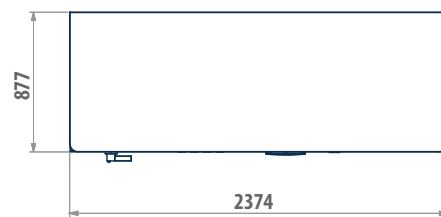
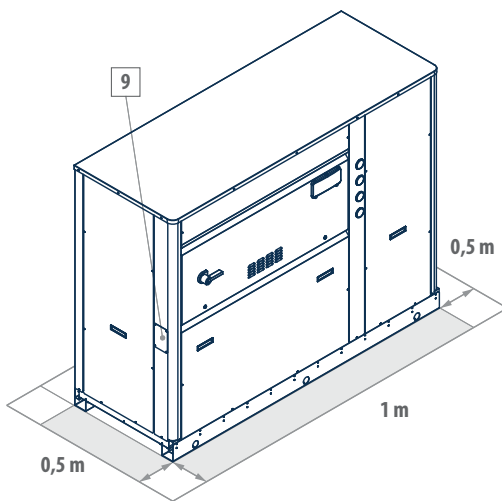
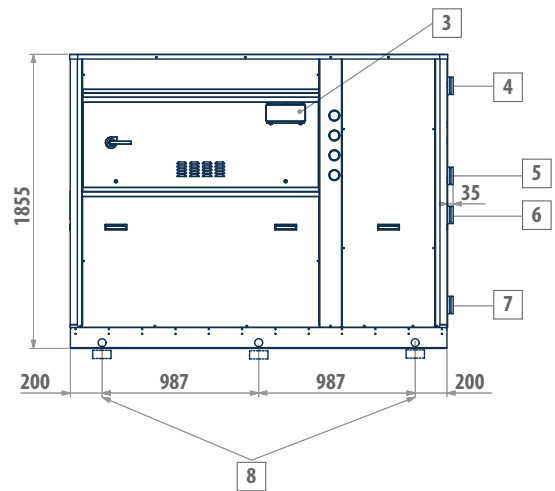
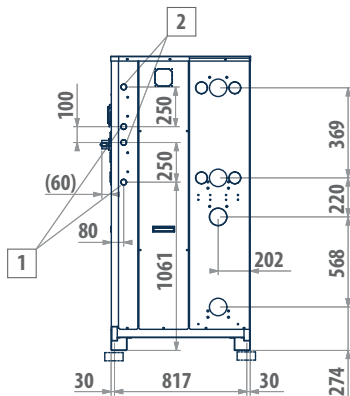

LEGEND VERSIONS C

1	Recovery side - inlet (M 1" gas)
2	Recovery side - outlet (M 1" gas)
3	User interface
4	Dissipation side - outlet (Victaulic 2 1/2")
5	Dissipation side - inlet (Victaulic 2 1/2")
6	User side - inlet (Victaulic 3")
7	User side - outlet (Victaulic 3")
8	Power supply input

MODEL VERSION

LEW 283	C
LEW 284	C
LEW 314	C
LEW 344	C
LEW 374	C
LEW 424	C
LEW 484	C

DIMENSIONAL DRAWINGS

LEW 535 - 636

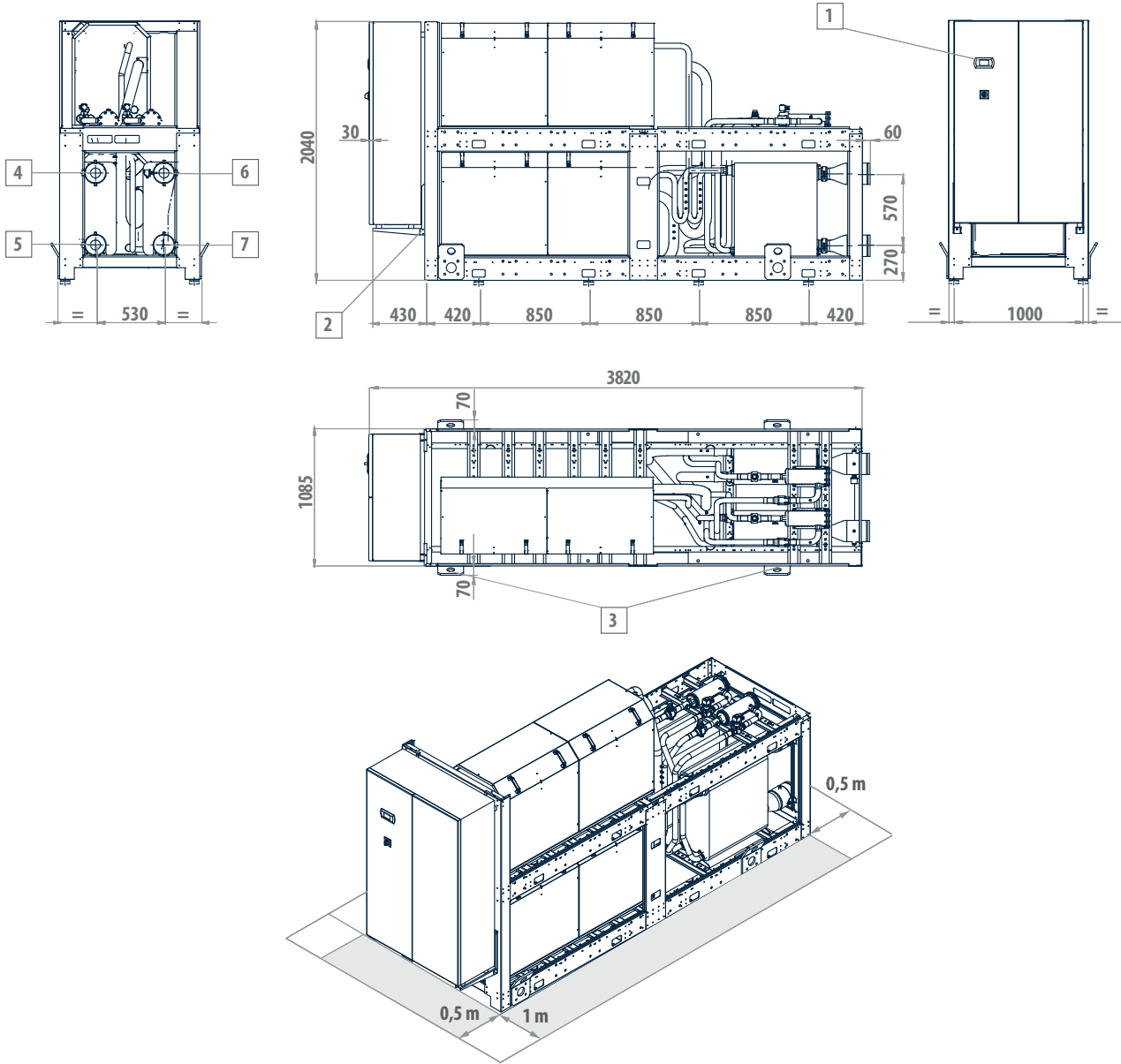

LEGEND VERSIONS C - D - H

1	User interface
2	Power supply input
3	Lifting points
4	Dissipation side - outlet (Victaulic 6")
5	Dissipation side - inlet (Victaulic 6")
6	User side - inlet (Victaulic 6")
7	User side - outlet (Victaulic 6")

LEGEND VERSIONS W

1	User interface
2	Power supply input
3	Lifting points
4	Dissipation side - inlet (Victaulic 6")
5	Dissipation side - outlet (Victaulic 6")
6	User side - outlet (Victaulic 6")
7	User side - inlet (Victaulic 6")

MODEL VERSION

LEW 535 C - D - H - W

LEW 576 C - D - H - W

LEW 636 C - D - H - W



MULTI-PURPOSE

Introduction	p. 288
HIWARM	p. 290
HIWARM COMPACT	p. 298
MCP	p. 302
LCP	p. 312
LEP	p. 330



Total heat recovery multi-purpose units

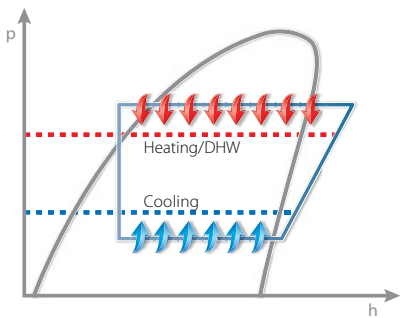

Energy saving thanks to a total recovery

Galletti multi-purpose heat pumps are total recovery units used for a simultaneous hot and cold water production. Available for a 2-pipe system, DHW production under request, or a 4-pipe system, designed for service and residential sectors. As well as winter heating and summer air conditioning, in case of a 2-pipe air-conditioning systems in which, thermal power for the DHW production is required, Galletti multi-purpose systems are equipped with a plate heat exchanger used for the DHW production. Thanks to the advanced technology of these systems, they can satisfy this request in every season, also when there is no need of air-conditioning, but that's not all! They can do that efficiently by using the total recovery of condensation heat available during cooling phase.

Production of chilled water with total condensation heat recovery for DHW production

- S1: "user side" plate exchanger
- S2: "DHW production side" plate exchanger
- S3: Finned block heat exchanger

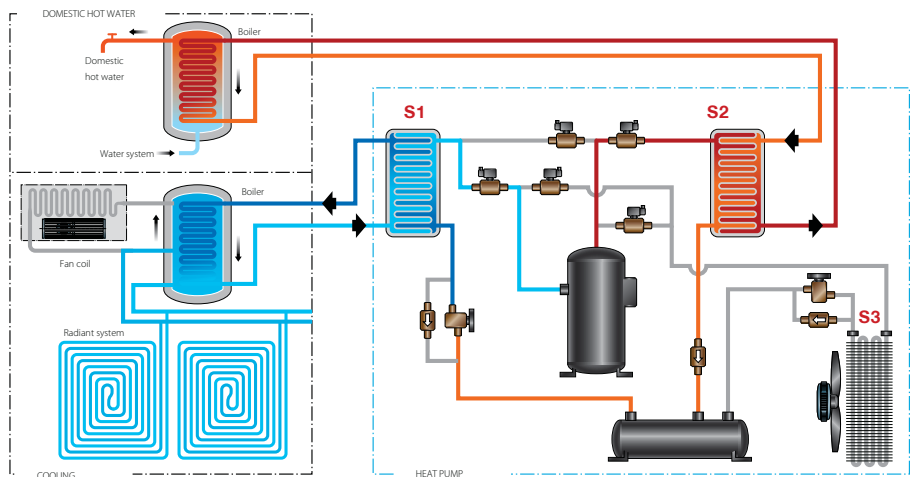



Partial load efficiency

It is necessary to guarantee that the generation system provides high values of COP/EER even in partial load efficiency which, often, corresponds to the greatest number of working hours in a seasonal cycle.

According to Galletti multi-purpose series, this purpose is achieved through a meticulous thermodynamic design of all main components.

As for the multi-purpose heat pumps which have one cooling circuit, it is possible to modulate the thermal power released through the variation of frequency in the single compressor activated by a BLDC motor.

When on-off compressors are used, high efficiency is guaranteed also for partial loads through different steps of operation due to compressors, divided in one or two thermodynamic circuits.

Additional total recovery heat pumps compared to traditional generation systems.

- » High renewable energy availability can be obtained from the environment using different methods
- » Respect for the environment through energy efficiency due to the excellent COP and EER values
- » Reduction in the consumption of fossil energy (ideal for photovoltaic systems combinations)
- » Risks of explosion, fire and indoor burning materials poisoning prevented
- » Totally programmable with the possibility of remote management and on line assistance
- » Low maintenance due to the absence of wearing parts
- » Low-noise execution
- » No CO₂ and local harmful emissions
- » It does not pollute and it can be fueled by renewable energy sources
- » Maximum savings on running costs combined with high environmental sustainability
- » One unit substituting boilers and air-conditioning units



Total heat recovery multi-purpose units HIWARM

Air-water system with external and internal BLDC unit

HIWARM 12 - 33 kW



Axial fan



Refrigerant R-410A



Heating/ Cooling



Total heat recovery multi-purpose unit



Multi-purpose 2 pipes system



BLDC scroll compressor



Split version

PLUS

- » Total heat recovery for DHW production
- » Twin-rotary or scroll electronically-controlled compressor driven by an electric BLDC motor
- » Electronically controlled electronic expansion valve
- » Double cycle reversal, water side
- » BLDC circulators with stainless steel impeller for system and DHW

The perfect combination between multi-purpose, inverter technology and style

The multi-purpose system HIWARM is the most evolved and efficient solution for conditioning and for the production of DHW in residential or commercial applications: thanks to the total recovery of condensation heat, it is possible to obtain thermal power in a totally free way during summer conditioning.

HIWARM is composed of an outdoor and indoor unit created to be installed in a technical room.

Inside the indoor unit, the compressor, heat exchangers of the systems, hydronic kits, management switchboard and all the main components of the cooling circuit are housed; instead, in the external unit, extremely versatile, there are finned exchanger and electric fans.

This solution has the remarkable advantage to keep all hydraulic circuits inside the building thus avoiding the need to protect the system from the risk of freezing through the use of heating elements or by adding glycol-based materials. Both these solutions inevitably lead to an increase of the consumption of electrical energy.

Moreover, the external unit thus created has a double advantage: it can be easily installed both vertically and horizontally and, since it is particularly lightweight, doesn't need expensive supporting structures.

HIWARM includes the state of the art as regards cooling and hydraulic components: from the compressor activated by a BLDC motor to maximize energetic efficiency in every operating mode, to the axial fans with airfoil blades and external rotor motor, from the high efficiency plate heat exchangers to the electronically-controlled electrical expansion valve managed by a PID regulation algorithm. The thermal exchange has been optimized in every operating mode through the use of a 4-way reverse cycle valve on the water side to always keep opposite the flow of refrigerant and thermal fluids, thus extending the operating range of the unit.

The modulation of capacity facilitates the variation of the thermal load of the building. During the operation and production of DHW, HIWARM transfers all its available power to compensate, in the most efficient way, the withdrawal of domestic hot water.

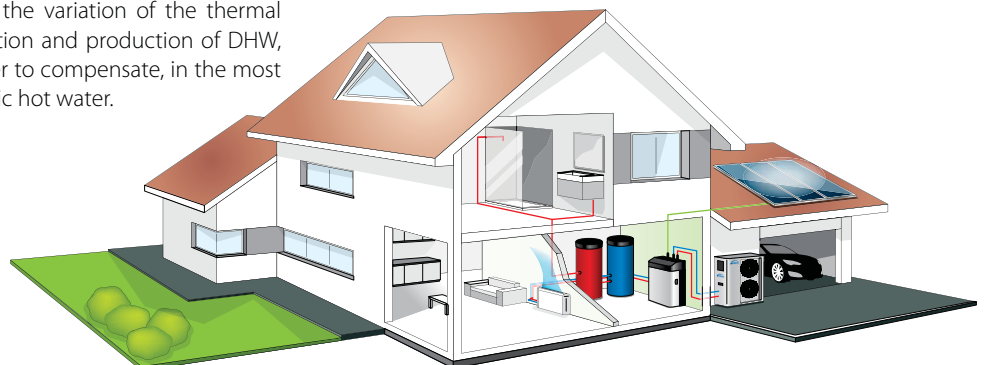

MAIN COMPONENTS

Outdoor unit

Finned coil made of copper pipes mechanically fixed to steel fins, accurately designed to minimize defrosting phase and optimize the efficiency of thermal exchange in every operating mode.



Indoor unit

Made of painted sheet. Enclosing panels made of painted galvanized sheet with polymerized epoxy-polyester powders and available in four different colours for a pleasant aesthetic.

Electronically controlled electronic expansion valve

Together with the compressor, it is the key element for the operation of the unit. Thanks to the PID algorithm that regulates it, it is capable of quickly adjusting to every working condition and maintain the cooling cycle steady.

Compressor

Twin-rotary or scroll hermetic compressor activated by BLDC permanent magnet motor and included in a completely sound-proof paneling, isolated from the main structure through anti-vibrating rubber dampers.

Microprocessor control

The cutting-edge microprocessor control includes a high-technology software developed by Galletti which allows the complete and efficient management of HIWARM units.



Hydraulic kit

Centrifugal circulators activated by BLDC electrical motors with stainless steel impeller and managed by the control panel of the unit to adjust the flow rate of water according to operating conditions and keep the compressor within its operating range.

CONFIGURATOR

The models are completely configurable by selecting the version and the options. To the right is shown an example of configuration.

Version	Fields	1	2	3	4	5	6	7	8	9
HWM012MO		4	7	7	0	C	0	0	A	0

To verify the compatibility of the options, use the selection software or the price list.

AVAILABLE VERSIONS

Total heat recovery multi-purpose unit

HWM...MO Indoor unit for 2-pipe system + external remote unit with horizontal air flow
HWM...MV Indoor unit for 2-pipe system + external remote unit with vertical air flow

CONFIGURATION OPTIONS

- | | |
|--|--|
| <p>1 Power supply
 4 230 V - 1 - 50 Hz + magnetic breakers
 5 400 V - 3 N - 50 Hz + magnetic breakers</p> <p>2 User side water pump
 7 Variable flow LP pump</p> <p>3 Recovery water pump
 7 Variable flow LP pump</p> <p>4 Remote communication
 0 Absent
 1 RS485 serial board (Carel / Modbus protocol)
 2 LON FTT10 serial board (advanced controller required)
 3 GSM modem board (advanced controller required)
 4 BACNET IP / PCOWEB serial board + supervision software Gweb (advanced controller required)
 6 BACNET IP / PCOWEB serial board + clock board + supervision software Gweb (advanced controller required)</p> <p>5 Air flow modulation
 C Condensation control by phase-cut fans
 E Condensation control performed by EC fans</p> | <p>6 Remote control
 0 Absent
 3 Remote simplified user panel for advanced controller</p> <p>7 Packing
 0 Standard
 1 Wooden cage
 2 Wooden crate</p> <p>8 Indoor unit colour
 A Metallic silver grey - RAL 9006
 B Glossy white - RAL 9016
 G Glossy dark grey - RAL 7016
 P Glossy petroleum blue - RAL 7031
 R Glossy bordeaux - RAL 3003</p> <p>9 Special coils / Protective treatments
 0 Standard
 B Pre-painted fins with epoxy painting
 C Cataphoresis
 R Copper-copper</p> |
|--|--|

ACCESSORIES

A Outdoor finned coil heat exchanger protection grille	C Directives reference other than "2014/68/UE - PED"
B Two pairs of Victaulic joints	

Total heat recovery multi-purpose units HIWARM

RATED TECHNICAL DATA

HIWARM			012		022		033	
Speed			min	max	min	max	min	max
Power supply		V-ph-Hz	230 - 1 - 50		400 - 3N - 50		400 - 3N - 50	
Cooling mode operation								
Cooling capacity	(1)	kW	3,04	11,2	9,20	23,2	9,57	32,0
Total power input	(1)	kW	0,78	3,31	2,41	7,60	2,39	11,3
EER	(1)		3,90	3,38	3,82	3,05	4,00	2,83
SEER	(2)		4,78		4,73		4,91	
Water flow	(1)	l/h	522	1935	1583	3998	1646	5525
Water pressure drop	(1)	kPa	5	19	5	21	5	17
Available pressure head - LP pumps	(1)	kPa	66	42	111	86	113	80
Cooling mode operation and DHW in total recovery								
Cooling capacity	(3)	kW	2,75	10,6	8,65	22,7	8,95	31,8
DHW heating capacity	(3)	kW	3,41	13,7	10,8	29,6	11,0	41,9
Total power input	(3)	kW	0,75	3,55	2,47	7,78	2,37	11,4
COP HRE	(3)		8,23	6,85	7,89	6,72	8,44	6,46
Water flow user side	(3)	l/h	474	1827	1489	3919	1540	5479
Water pressure drop user side	(3)	kPa	5	17	5	20	5	17
Available pressure head user side - LP pumps	(3)	kPa	66	45	112	87	113	81
Water flow DHW side	(3)	l/h	592	2368	1877	5109	1917	7236
Water pressure drop DHW side	(3)	kPa	5	27	5	32	5	28
Available pressure head DHW side - LP pumps	(3)	kPa	65	27	108	68	111	55
Heating or DHW operation								
Heating capacity	(4)	kW	2,96	12,0	9,56	25,7	9,77	36,0
Total power input	(4)	kW	3,57	0,89	2,66	7,66	2,68	11,4
COP	(4)		3,33	3,36	3,59	3,31	3,65	3,16
SCOP	(2)		3,19		3,20		3,28	
Heating energy efficiency class	(5)		A++					
Water flow	(4)	l/h	517	2078	1658	4441	1696	6225
Water pressure drop	(4)	kPa	5	22	5	25	5	21
Available pressure head - LP pumps	(4)	kPa	65	37	110	79	112	71
General data								
Maximum current absorption		A	22		20		33	
Compressors / circuits			1 / 1					
Sound power level - indoor unit	(6)	dB(A)	54		55		57	
Sound power level - outdoor unit	(6)	dB(A)	65		66		69	
Weight - indoor unit		kg	190		260		270	
Weight - outdoor unit		kg	50		100		123	

(1) Outdoor air temperature 35°C, water temperature 12°C / 7°C (EN14511:2013)

(2) η efficiency values for heating and cooling are respectively calculated by the following formulas: $[\eta = SCOP / 2,5 - F(1) - F(2)]$ e $[\eta = SEER / 2,5 - F(1) - F(2)]$. For further information, please refer to the technical document "ErP 2009/125/EC DIRECTIVE" in the catalogue introducing pages, or to the EN14825:2017 regulation.

(3) Cooling water temperature 12°C / 7°C, recovery water temperature 40°C / 45°C (EN14511:2013)

(4) Outdoor air temperature dry bulb 7°C / wet bulb 6°C, water temperature 40°C / 45°C (EN14511:2013)

(5) Seasonal energy efficiency class for MEDIUM TEMPERATURE room heating under AVERAGE climatic conditions [EUROPEAN REGULATION No 811/2013]

(6) Sound power level measured according to ISO 9614

DIMENSIONAL DRAWINGS

INDOOR UNIT HIWARM 012

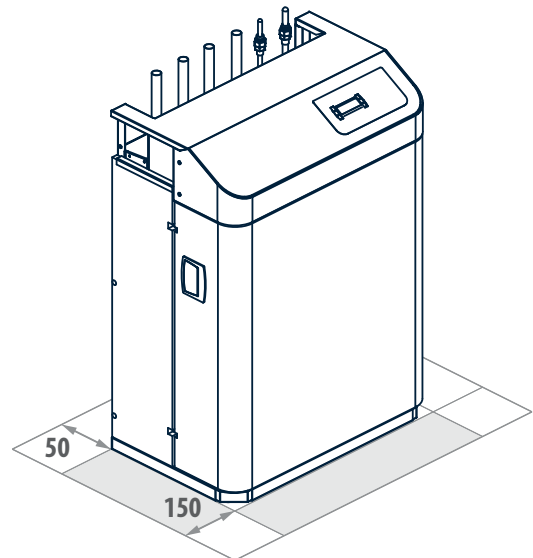
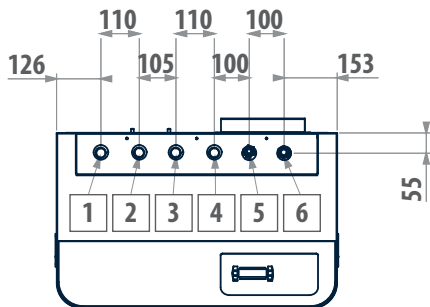
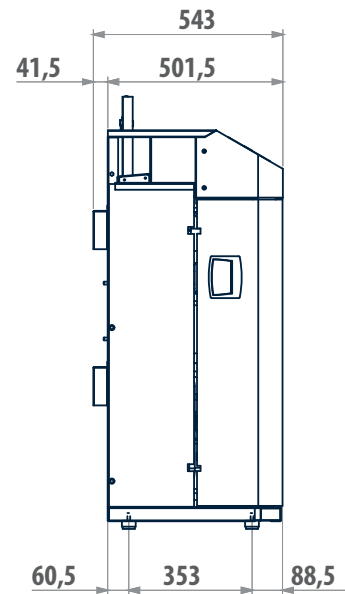
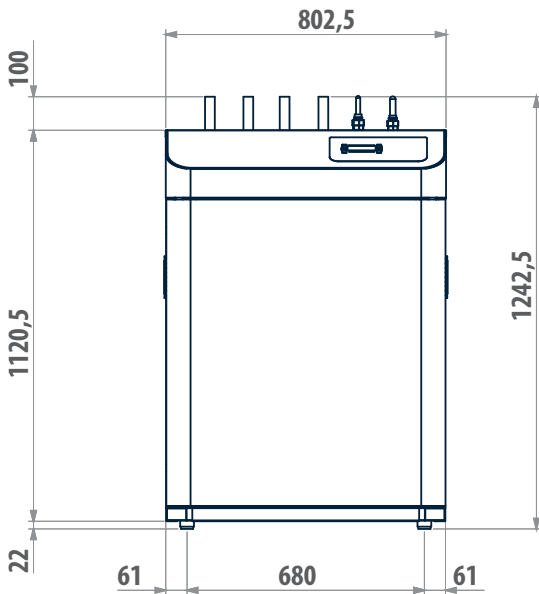

LEGEND

- | | |
|---|---|
| 1 | Water outlet - air conditioning system (ø 28 copper pipe) |
| 2 | Water inlet - air conditioning system (ø 28 copper pipe) |
| 3 | Water outlet - DHW system (ø 28 copper pipe) |
| 4 | Water inlet - DHW system (ø 28 copper pipe) |
| 5 | Liquid line (ø 12 Rotalock) |
| 6 | Gas line (ø 16 Rotalock) |

Total heat recovery multi-purpose units HIWARM

DIMENSIONAL DRAWINGS

HIWARM 012 EXTERNAL UNIT WITH HORIZONTAL AIR FLOW

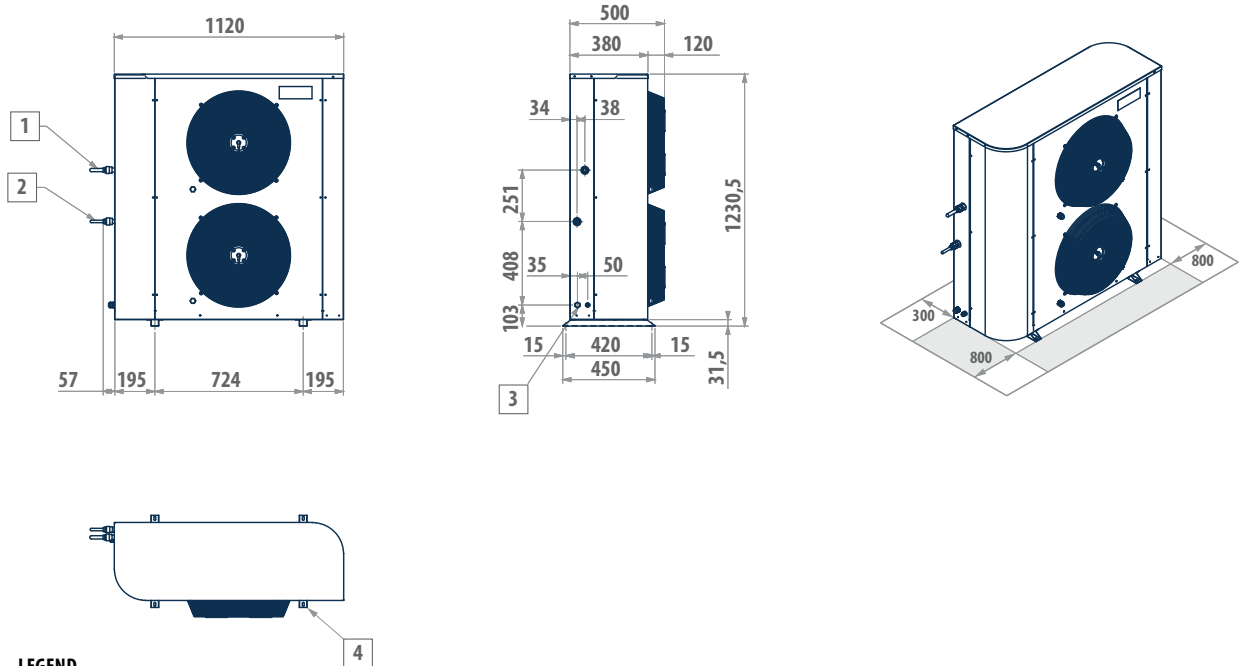

LEGEND

- | | |
|---|-----------------------------|
| 1 | Gas line (ø 16 Rotalock) |
| 2 | Liquid line (ø 12 Rotalock) |
| 3 | Power supply |
| 4 | Lifting holes |

HIWARM 012 EXTERNAL UNIT WITH VERTICAL AIR FLOW

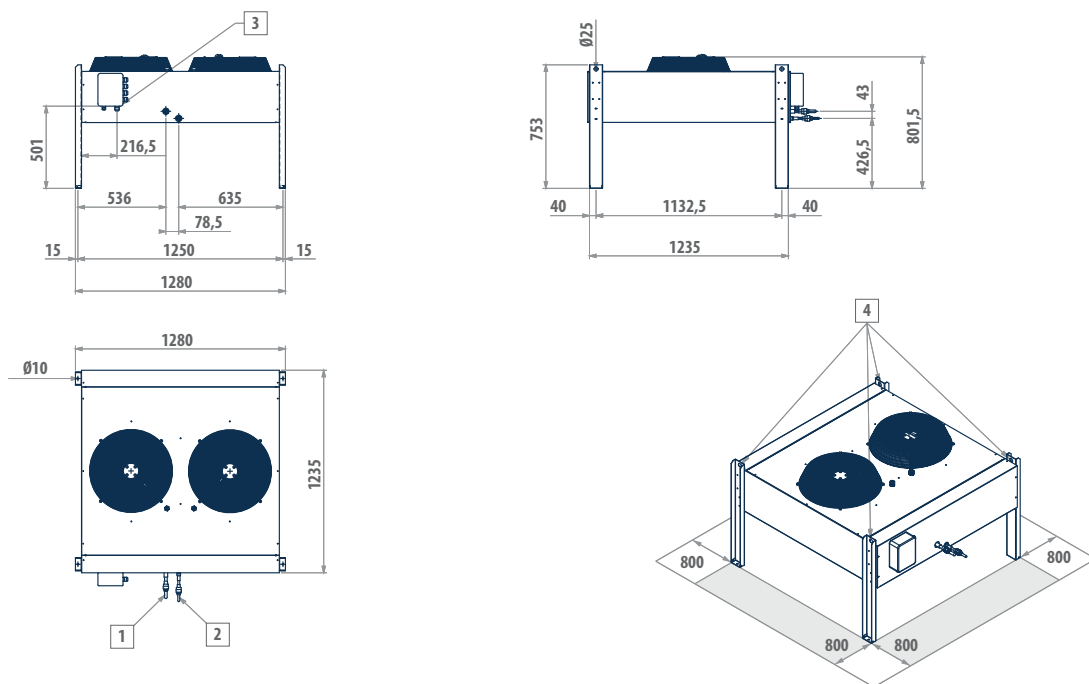

LEGEND

- | | |
|---|-----------------------------|
| 1 | Gas line (ø 16 Rotalock) |
| 2 | Liquid line (ø 12 Rotalock) |
| 3 | Power supply |
| 4 | Lifting holes |

DIMENSIONAL DRAWINGS

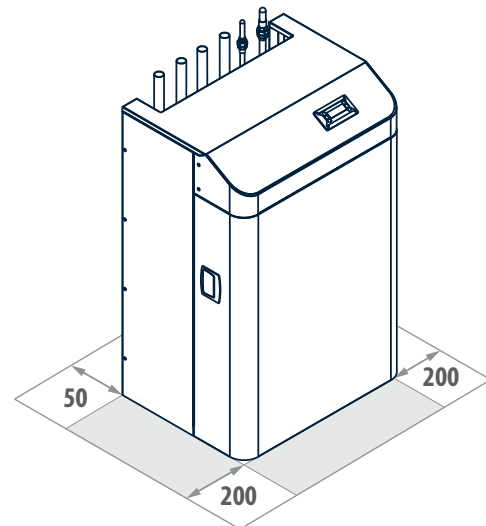
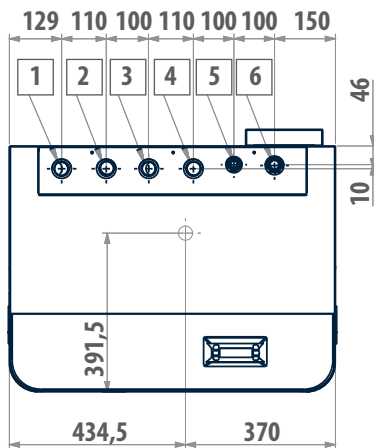
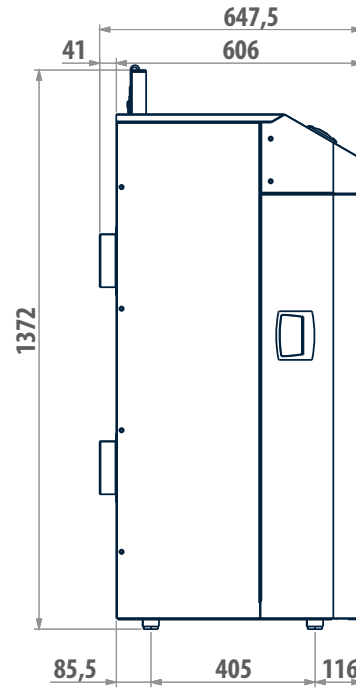
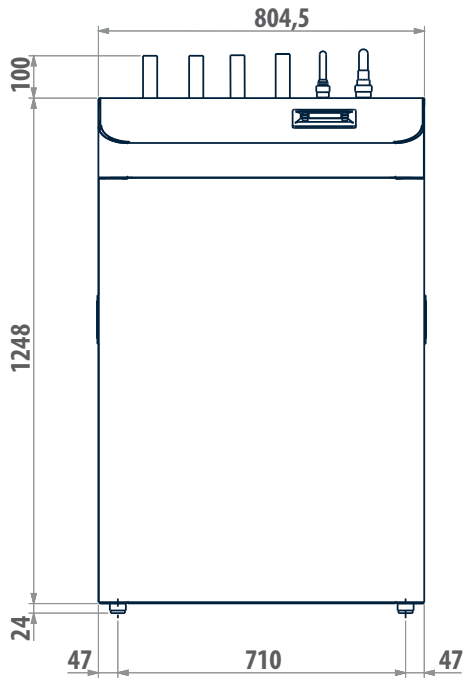
INDOOR UNIT HIWARM 022 - 033

LEGEND

- | | |
|---|--|
| 1 | Water outlet - air conditioning system copper pipe (HIWARM 022: Ø 35) (HIWARM 033: Ø 35) |
| 2 | Water inlet - air conditioning system copper pipe (HIWARM 022: Ø 35) (HIWARM 033: Ø 35) |
| 3 | Water outlet DHW system copper pipe (HIWARM 022: Ø 35) (HIWARM 033: Ø 35) |
| 4 | Water inlet DHW system copper pipe (HIWARM 022: Ø 35) (HIWARM 033: Ø 35) |
| 5 | Liquid line Rotalock (HIWARM 022: Ø 12) (HIWARM 033: Ø 16) |
| 6 | Gas line Rotalock (HIWARM 022: Ø 22) (HIWARM 033: Ø 22) |

Total heat recovery multi-purpose units HIWARM

DIMENSIONAL DRAWINGS

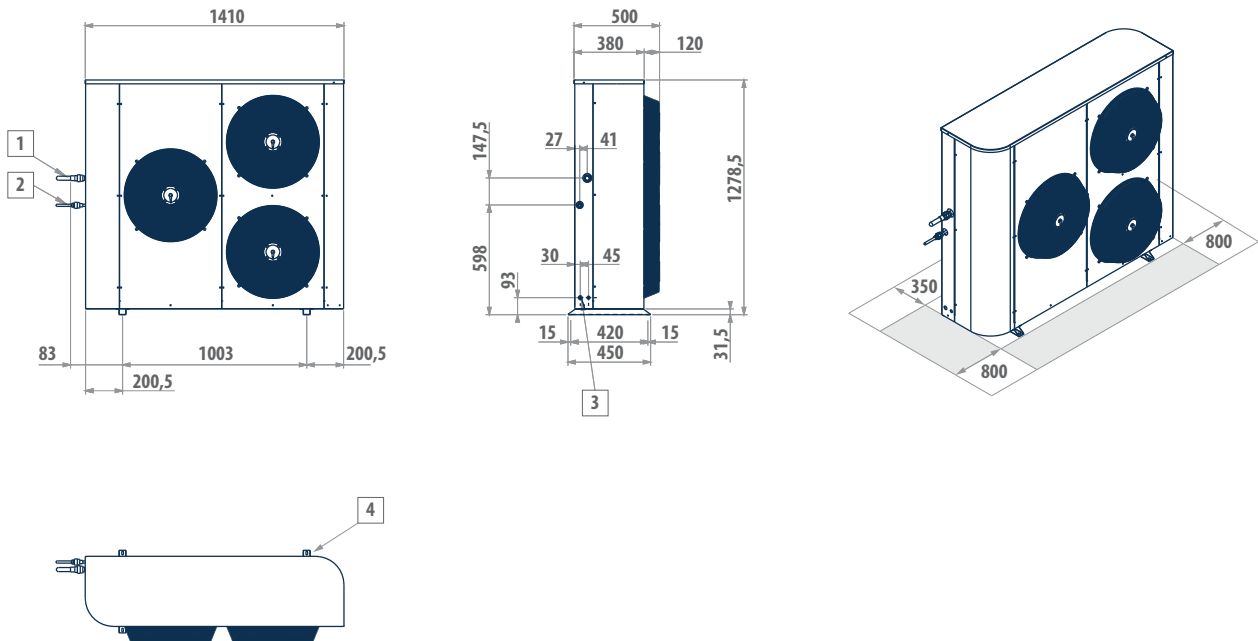
HIWARM 022 EXTERNAL UNIT WITH HORIZONTAL AIR FLOW



LEGEND

- | | |
|---|-----------------------------|
| 1 | Gas line (ø 22 Rotalock) |
| 2 | Liquid line (ø 16 Rotalock) |
| 3 | Electrical connection |
| 4 | Lifting holes |

HIWARM 022 EXTERNAL UNIT WITH VERTICAL AIR FLOW

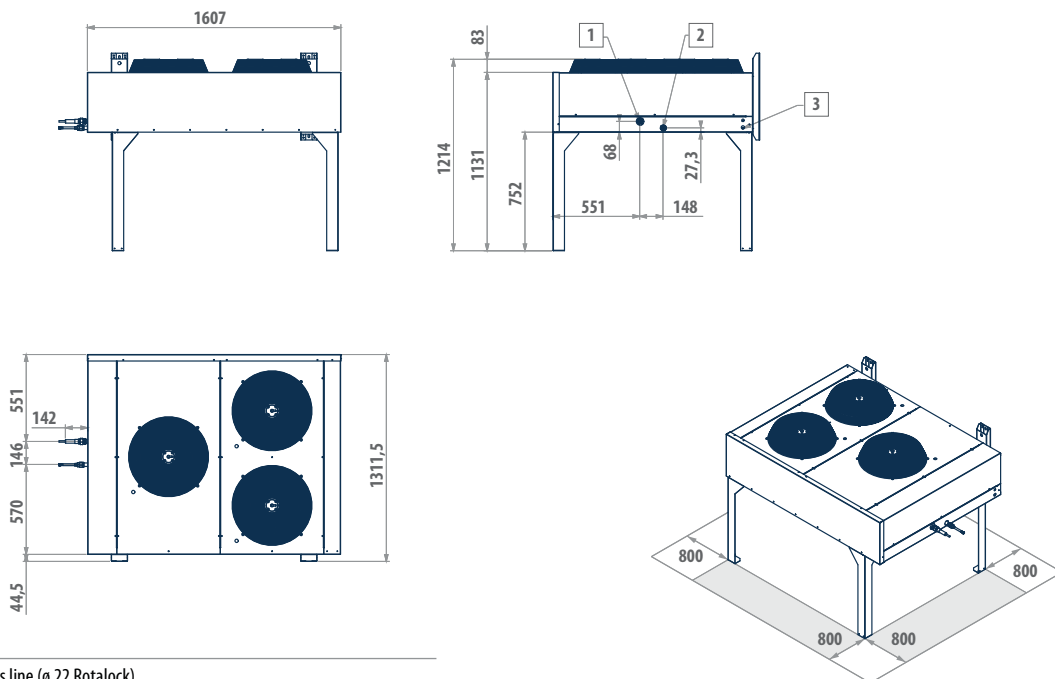

LEGEND

- | | |
|---|-----------------------------|
| 1 | Gas line (ø 22 Rotalock) |
| 2 | Liquid line (ø 16 Rotalock) |
| 3 | Electrical connection |
| 4 | Lifting holes |

DIMENSIONAL DRAWINGS

HIWARM 033 EXTERNAL UNIT WITH HORIZONTAL AIR FLOW

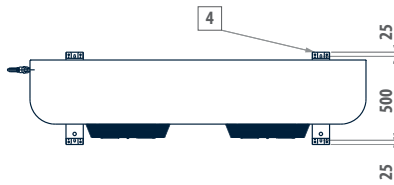
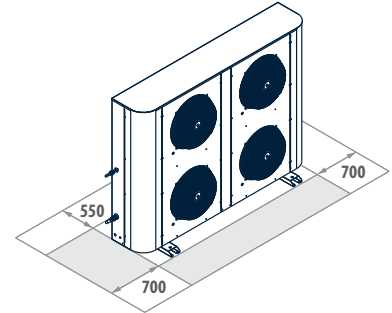
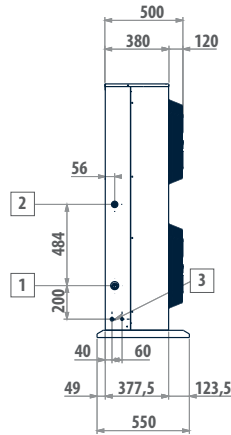
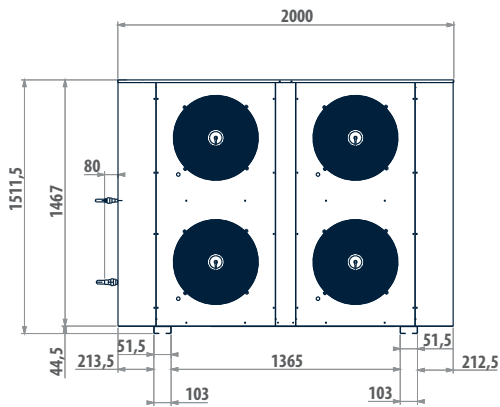

LEGEND

- 1 Gas line (ø 22 Rotalock)
- 2 Liquid line (ø 16 Rotalock)
- 3 Electrical connection
- 4 Lifting holes

HIWARM 022 EXTERNAL UNIT WITH VERTICAL AIR FLOW

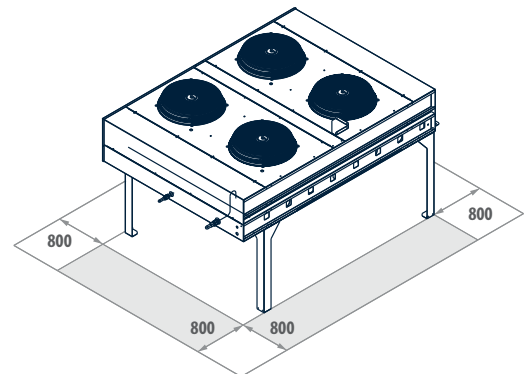
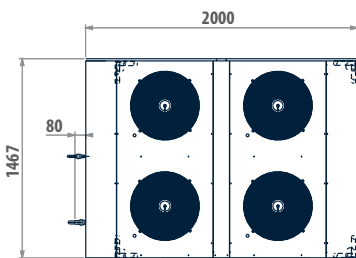
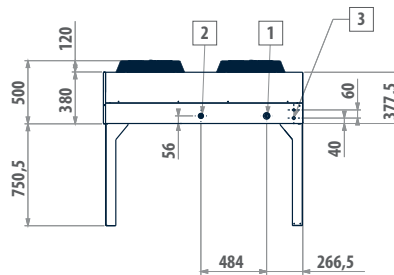
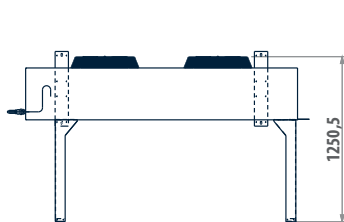

LEGEND

- 1 Gas line (ø 22 Rotalock)
- 2 Liquid line (ø 16 Rotalock)
- 3 Electrical connection
- 4 Lifting holes

Total heat recovery multi-purpose units HWMC

Outdoor packaged air-water unit with BLDC compressor

HIWARM COMPACT 10 - 29 kW



Axial fan



Refrigerant R-410A



Heating/ Cooling



Packaged execution



Total heat recovery multi-purpose unit



Multi-purpose 2 pipes system



BLDC scroll compressor

PLUS

- » Total heat recovery for DHW production
- » Twin-rotary or scroll electronically-controlled compressor driven by an electric BLDC motor
- » Electronically controlled electronic expansion valve
- » Modulating hydraulic pumps with a stainless steel impeller

HIWARM COMPACT can represent the only system generator for residential use, single or centralized.
In dual-purpose/bioenergetic systems, it is managed by EVO SYSTEM.

Total recovery and energy efficiency in every condition

The HIWARM COMPACT units have been designed to cool and heat water for air conditioning systems and for the production of DHW for residential or commercial use. They are total heat recovery multi-purpose units with 2 separated circuits, whose operating modes are described below:

- cold water production in summer for the air conditioning system
- cold water production for the air conditioning system with total condensation heat recovery for DHW production
- hot water production for the heating system
- production of DHW during winter or mid-seasons with priority over heating.

Thanks to high-standard performances of the main components used, HIWARM COMPACT operating range is particularly extended and allows a proper and effective response to the need of residential or commercial buildings even with low external temperatures, making the use of additional heat power units unnecessary. Thanks to a reliable engineering and a management software specifically developed by Galletti R&D Dpt, the BLCD variable-speed compressor responds every minute to the system's requests by adjusting the produced power in the most efficient way.

The compact dimensions and the hydronic kit included, not to mention the wide range of options and accessories, guarantee a simple installation without requiring excessive dedicated spaces.

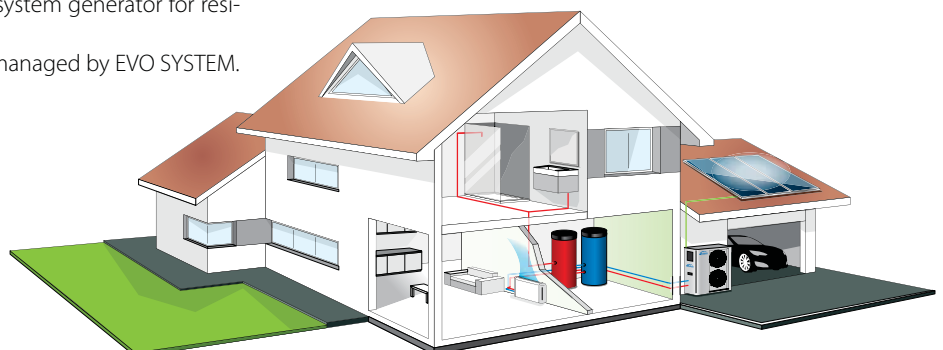

MAIN COMPONENTS

Structure

The cabinet, made of galvanized and painted sheet, has been created to resist to atmospheric agents and allow a comfortable access to the internal components for maintenance.

Microprocessor control

Developed according to the most recent technologies, the microprocessor control allows the complete management of HIWARM COMPACT units through a specifically designed software by Galletti.



Electronically controlled electronic expansion valve

By rapidly adjusting to the variation of workloads and thus integrating the activities carried out by the compressor, it represents one of the key components of the units and it assures the efficiency and stability of its operation.

Heat exchanger

The finned exchanger is made of copper pipes mechanically fixed to aluminium fins: thanks to the accurate design, it guarantees the maximum efficiency in every operating mode and it facilitates defrosting phases.

Compressor

It is housed in a completely closed space and it is further made sound-proof through the use of sound-proofing insulation. Hermetic twin-rotary or scroll activated by a BLDC permanent magnet motor is fixed on the base though anti-vibration dampers.

Hydraulic kit

The centrifugal circulators (both system and DHW side) can be of modulating type with a stainless steel impeller which allows the operation with water mixtures and ethylene glycol up to 35%. Moreover, an expansion tank and an automatic loading tap are included.



CONFIGURATOR

The models are completely configurable by selecting the version and the options. To the right is shown an example of configuration.

Version	Fields	1	2	3	4	5	6	7	8	9	10	11	12	13
HWMC010HMAA		A	6	S	3	E	E	0	0	0	0	G	0	0

To verify the compatibility of the options, use the selection software or the price list.

AVAILABLE VERSIONS

Total heat recovery multi-purpose unit

HWMC...HOAA Unit with 400V - 3N - 50 Hz power supply

HWMC...HMAA Unit with 230V - 1 - 50 Hz power supply

CONFIGURATION OPTIONS

1 Expansion valve

A Electronic

2 Water pump and accessories

0 Absent

2 Variable flow LP system water pump + expansion vessel

3 EC system water pump + expansion vessel

5 Variable flow system LP water pump + DHW LP water pump + expansion vessels

6 EC system water pump + DHW EC water pump + expansion vessels

3 Water buffer tank

0 Absent

S Selected

4 Auxiliary

0 Absent

1 User water tank sensor probe

2 Electrical capacity integration management

3 User water tank sensor probe and electrical capacity integration management

5 Air flow modulation

C Condensation control by phase-cut fans

E Condensation control performed by EC fans

6 Antifreezing kit

1 Plate exchangers + 1 pump

2 Plate exchangers + 1 pump + water tank

3 Plate exchangers + 2 pumps

4 Plate exchangers + 2 pumps + water tank

E Plate exchanger

7 Acoustic insulation and attenuation

0 Absent

1 Compressor compartment acoustic insulation

2 Compressor sound blanket

3 Compressor compartment acoustic insulation and sound blanket

8 Refrigerant pipework accessories

0 Absent

M Refrigerant pressure gauges

9 Remote control / Serial communication

0 Absent

B My Chiller Base for multifunction units (RS485 serial board required)

C Remote user panel for advanced controller

F BACNET MS/TP / PCONET serial board (advanced controller required)

G BACNET IP / PCOWEB serial board + supervision software Gweb (advanced controller required)

P My Chiller Plus for multifunction units (RS485 serial board required)

W BACNET IP / PCOWEB serial board (advanced controller required)

10 Special coils / Protective treatments

0 Standard

B Pre-painted fins with epoxy painting

C Cataphoresis

I Hydrophilic

R Copper-copper

11 Outdoor finned coil heat exchanger protection

0 Absent

G Outdoor finned coil heat exchanger protection grille

12 Compressors options

0 Absent

1 Outdoor coil trace heater

13 Additional boards

0 Absent

1 RS485 serial board (Carel / Modbus protocol)

2 Clock board (advanced controller required)

3 LON FTT10 serial board (advanced controller required)

14 Packing

0 Standard

1 Wooden cage

2 Wooden crate

ACCESSORIES

RYKAMF Spring anti vibration shock mounts

RYPAM Rubber anti vibration shock mounts

Total heat recovery multi-purpose units HWMC

RATED TECHNICAL DATA

HIWARM COMPACT			010M		013		018		023		029	
Speed			min	max	min	max	min	max	min	max	min	max
Power supply		V-ph-Hz	230 - 1 - 50		400 - 3N - 50		400 - 3N - 50		400 - 3N - 50		400 - 3N - 50	
Cooling mode operation												
Cooling capacity	(1)	kW	2,90	10,5	5,68	13,7	5,64	18,4	9,04	23,3	9,10	29,4
Total power input	(1)	kW	0,90	3,41	1,61	4,45	1,61	7,65	2,54	7,54	2,59	11,7
EER	(1)		3,22	3,08	3,53	3,08	3,50	2,41	3,56	3,09	3,51	2,51
SEER	(2)		4,05		4,07		3,96		3,85		3,91	
Water flow	(1)	l/h	499	1824	978	2370	970	3178	1556	4019	1565	5088
Water pressure drop	(1)	kPa	5	21	5	18	5	31	5	24	5	30
Available pressure head - LP pumps	(1)	kPa	182	127	205	157	205	117	198	147	198	120
Cooling mode operation and DHW in total recovery												
Cooling capacity	(3)	kW	2,66	10,1	5,30	13,5	5,26	18,8	8,54	23,1	8,60	30,3
DHW heating capacity	(4)	kW	3,29	13,0	6,61	17,3	6,56	25,1	10,5	29,3	10,6	39,6
Total power input	(3)	kW	0,73	3,48	1,51	4,39	1,50	7,35	2,22	7,28	2,26	10,9
COP HRE	(3)		8,16	6,67	7,88	7,04	7,87	6,01	8,56	7,23	8,50	6,44
Water flow user side	(3)	l/h	457	1739	912	2330	905	3259	1471	3983	1481	5233
Water pressure drop user side	(3)	kPa	5	19	5	18	5	32	5	24	5	32
Available pressure head user side - LP pumps	(3)	kPa	183	132	206	159	206	112	199	148	199	115
Water flow DHW side	(3)	l/h	573	2266	1148	3001	1141	4365	1820	5092	1838	6886
Water pressure drop DHW side	(3)	kPa	5	28	5	25	5	51	6	39	5	46
Available pressure head DHW side - LP pumps	(3)	kPa	179	97	199	128	199	45	191	107	193	57
Heating or DHW operation												
Heating capacity	(5)	kW	2,83	11,5	5,81	15,0	5,79	21,7	9,17	25,8	9,31	33,9
Total power input	(5)	kW	0,99	3,52	1,74	4,42	1,85	7,68	2,95	8,21	3,07	12,2
COP	(5)		2,86	3,27	3,34	3,39	3,13	2,83	3,11	3,14	3,03	2,78
SCOP	(2)		3,05		3,09		2,83		2,96		2,85	
Heating energy efficiency class	(6)		A+									
Water flow	(5)	l/h	494	1978	1007	2589	1004	3736	1589	4449	1615	5857
Water pressure drop	(5)	kPa	5	22	5	19	5	38	5	31	5	34
Available pressure head - LP pumps	(5)	kPa	181	117	203	149	203	89	195	131	197	101
General data												
Maximum current absorption		A	25		12		12		18		26	
Compressors / circuits			1 / 1									
Expansion vessel volume (User side / DHW)		dm ³	5 / 1									
Buffer tank volume		dm ³	30		30		30		50		50	
Sound power level	(7)	dB(A)	71		71		71		74		74	
Transport weight unit with pump and tank		kg	241		295		295		358		358	
Operating weight unit with pump and full tank		kg	257		303		303		395		395	

(1) Outdoor air temperature 35°C, water temperature 12°C / 7°C (EN14511:2013)

(2) η efficiency values for heating and cooling are respectively calculated by the following formulas: $[\eta = SCOP / 2,5 - F(1) - F(2)]$ e $[\eta = SEER / 2,5 - F(1) - F(2)]$. For further information, please refer to the technical document "ErP 2009/125/EC DIRECTIVE" in the catalogue introducing pages, or to the EN14825:2017 regulation.

(3) Cooling water temperature 12°C / 7°C, recovery water temperature 40°C / 45°C (EN14511:2013)

(4) Cooling water temperature 12°C / 7°C, recovery water temperature 40°C / 45°C

(5) Outdoor air temperature dry bulb 7°C / wet bulb 6°C, water temperature 40°C / 45°C (EN14511:2013)

(6) Seasonal energy efficiency class for MEDIUM TEMPERATURE room heating under AVERAGE climatic conditions [EUROPEAN REGULATION No 811/2013]

(7) Sound power level measured according to ISO 9614

DIMENSIONAL DRAWINGS

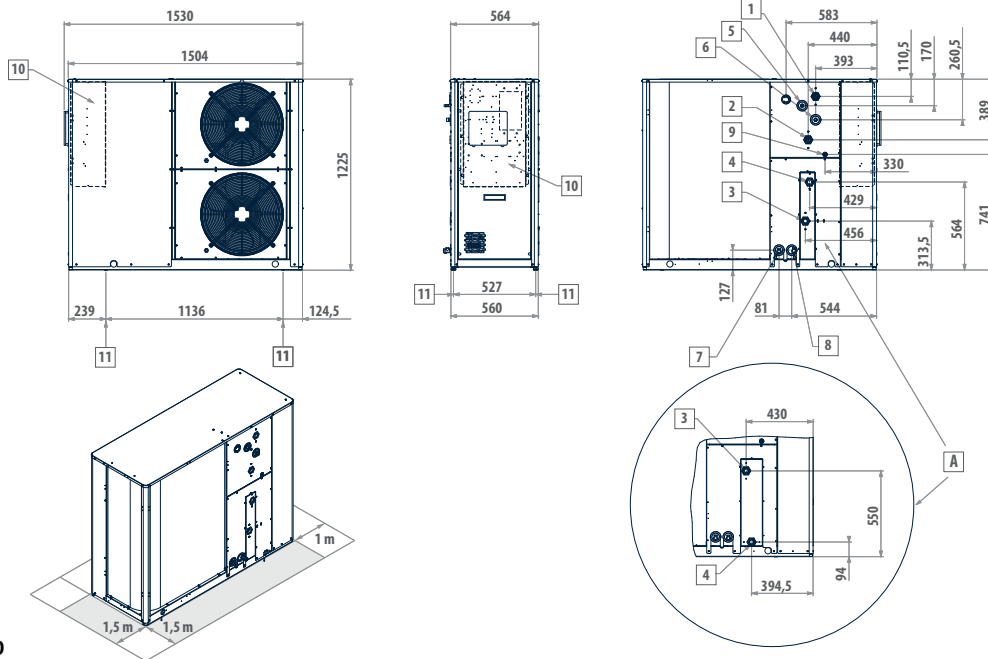
HIWARM COMPACT 10 - 18

LEGEND

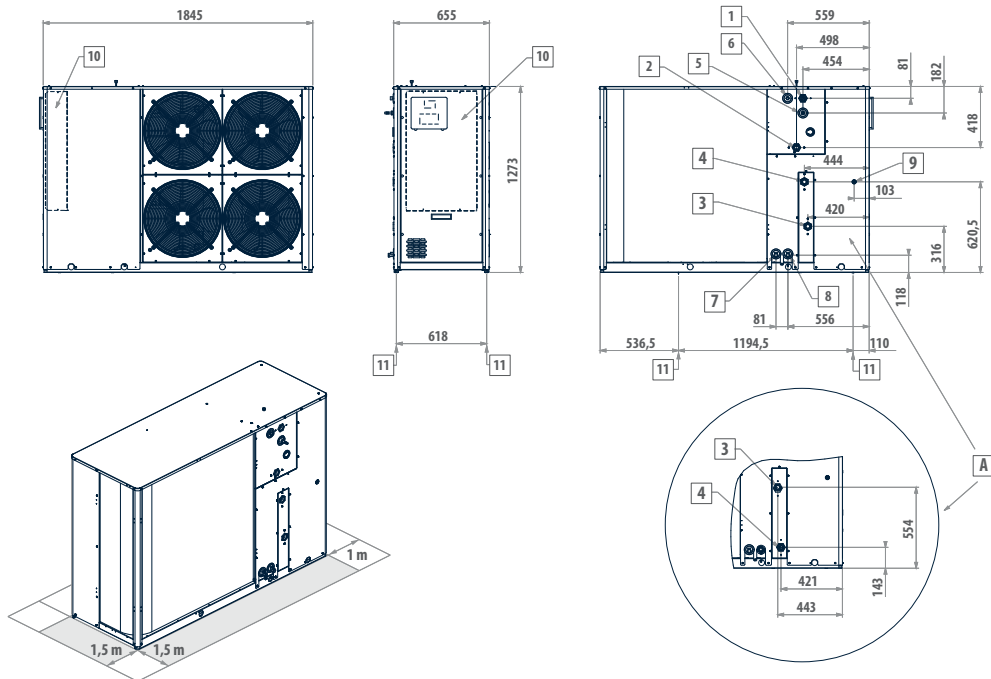
- | | |
|---|---|
| <ul style="list-style-type: none"> 1 System water inlet 1" 1/4 female 2 DHW inlet 1" 1/4 female 3 System water outlet 1" 1/4 female 4 DHW outlet 1" 1/4 female 5 Safety valve discharge outlet provided with rubber ring holder 6 Water supply 1/2" male (optional tap) | <ul style="list-style-type: none"> 7 System water outlet 1/2" female 8 DHW outlet 1/2" female 9 Power supply Ø 28 mm 10 Electric control board 11 Fastening points for vibration dampers A Version with EC pump |
|---|---|

HIWARM COMPACT 23 - 29

LEGEND

- | | |
|---|---|
| <ul style="list-style-type: none"> 1 System water inlet 1" 1/4 female 2 DHW inlet 1" 1/4 female 3 System water outlet 1" 1/4 female 4 DHW outlet 1" 1/4 female 5 Safety valve discharge outlet provided with rubber ring holder 6 Water supply 1/2" male (optional tap) | <ul style="list-style-type: none"> 7 System water outlet 1/2" female 8 DHW outlet 1/2" female 9 Power supply Ø 28 mm 10 Electric control board 11 Fastening points for vibration dampers A Version with EC pump |
|---|---|

Outdoor packaged air-water unit

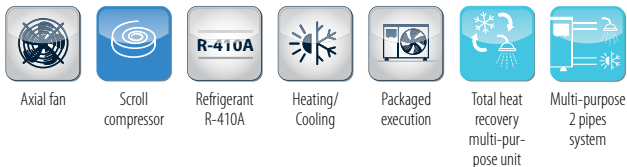
MCP 7 - 41 kW



PLUS

- » Total heat recovery for DHW production
- » High-reliability scroll compressors
- » Electronically controlled electronic expansion valve
- » Hydraulic pumps with stainless steel impeller for system and DHW

The multi-purpose systems of the MCP Galletti series can be easily integrated in photovoltaic systems for electrical energy production thus representing a single generator for all the need of air-conditioning, heating and DHW .

The complete and efficient solution for DHW and air conditioning.

As well as winter heating and summer air conditioning, the multi-purpose units of the MCP units are total recovery heat pumps designed to be used in residential or service sector in two-pipe air-conditioning systems in which thermal power for the production of DHW is required. Thanks to the advanced technology which characterizes it, not only MCP is capable of satisfying this request in every season (even when there are not air-conditioning needs) but it also does this in the most efficient and economic way by using the total recovery of condensation heat available during the cooling phase.

MCP units are equipped with scroll compressors and, depending on size and version, they are available for single-phase and three-phase supply. The energetic efficiency at partial load is assured by the availability of versions equipped with two compressors connected in parallel that offer a remarkable decrease of the absorbed electrical power when the load to meet is much lower than the maximum one thus allowing to maximize the seasonal efficiency of the system. Being available also in single-phase, combined executions are also effectively usable when high-power is requested without electrical three-phase availability.

The high quality of the components and the care in the sizing of heat exchangers are combined with a highly-developed management software, creating an extremely wide operating range that allows to conceive MCP as a single generator for a continuous use in every season.

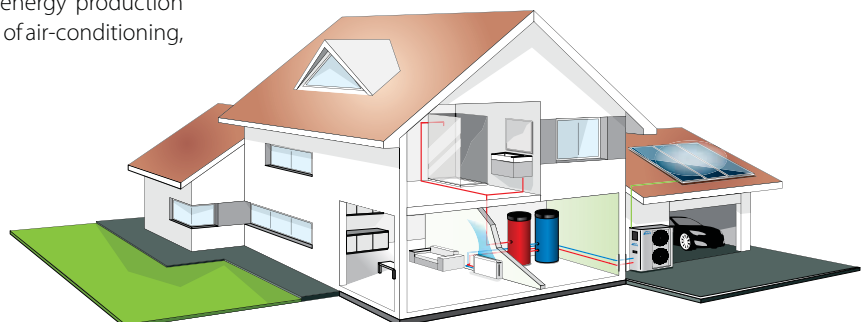

MAIN COMPONENTS

Structure

In galvanized and painted sheet, resistant to corrosive agents. Compressor compartment accessible from three sides thanks to easily removable panels also available with soundproofing inner insulation.

Hydraulic kit

Available for both circuits, it is composed of centrifugal circulators with stainless steel impeller that allows its use with water and ethylene glycol mixtures up to 35%. Expansion tank and filling tap are included.

Heat exchanger

Finned coil made of copper pipes mechanically fixed to steel fins, accurately designed to minimize defrosting phase and optimize the efficiency of thermal exchange in every operating mode.



Compressor

Hermetic scroll compressor operated by asynchronous motor and characterized by a wide operating range. It is secured to the base through rubber supports in order to reduce vibration transmission.



Electronic expansion valve

Born from the most recent technologies, it represents one of the key elements for the proper operation of the unit. It is managed by a PID algorithm to adapt quickly and precisely to every working condition and keep the refrigeration cycle steady.

Microprocessor control

It allows the complete management of MCP units in order to face requests coming from the system. It can also activate an electric heating element to be used in case of programmable anti-legionella cycles or as a backup in case of forced machine down time.

CONFIGURATOR

The models are completely configurable by selecting the version and the options. To the right is shown an example of configuration.

Version	Fields	1	2	3	4	5	6	7	8	9	10	11	12	13
MCP010HMAA		A	4	S	3	C	E	0	0	B	0	G	0	2

To verify the compatibility of the options, use the selection software or the price list.

AVAILABLE VERSIONS

Total heat recovery multi-purpose unit

MCP.H0AA Unit with 400V - 3N - 50 Hz power supply
MCP.HMAA Unit with 230V - 1 - 50 Hz power supply

MCP.H2AA Unit with circuit breakers and 400V - 3N - 50 Hz power supply
MCP.H4AA Unit with circuit breakers and 230V - 1 - 50 Hz power supply

CONFIGURATION OPTIONS

- 1 Expansion valve**
 - A Electronic
- 2 Water pump and accessories**
 - 0 Absent
 - 1 LP system water pump + expansion vessel
 - 2 Variable flow LP system water pump + expansion vessel
 - 3 EC system water pump + expansion vessel
 - 4 LP system water pump + DHW LP water pump + expansion vessels
 - 5 Variable flow system LP water pump + DHW LP water pump + expansion vessels
 - 6 EC system water pump + DHW EC water pump + expansion vessels
- 3 Water buffer tank**
 - 0 Absent
 - S Selected
- 4 Auxiliary**
 - 0 Absent
 - 1 ON/OFF status of the compressors
 - 2 Remote control for step capacity limit (advanced controller required)
 - 3 Electrical capacity integration management
 - 4 Compressor ON/OFF status and step capacity limit activation (advanced controller required)
- 5 Air flow modulation**
 - C Condensation control by phase-cut fans
 - E Condensation control performed by EC fans
- 6 Antifreezing kit**
 - 1 Plate exchangers + 1 pump
 - 2 Plate exchangers + 1 pump + water tank
 - 3 Plate exchangers + 2 pumps
 - 4 Plate exchangers + 2 pumps + water tank
 - E Plate exchanger
- 7 Acoustic insulation and attenuation**
 - 0 Absent
 - 1 Compressor compartment acoustic insulation
 - 2 Compressor sound blanket
 - 3 Compressor compartment acoustic insulation and sound blanket
- 8 Refrigerant pipework accessories**
 - 0 Absent
 - M Refrigerant pressure gauges
- 9 Remote control / Serial communication**
 - 0 Absent
 - B My Chiller Base for multifunction units (RS485 serial board required)
 - C Remote user panel for advanced controller
 - F BACNET MS/TP / PCONET serial board (advanced controller required)
 - G BACNET IP / PCOWEB serial board + supervision software Gweb (advanced controller required)
 - P My Chiller Plus for multifunction units (RS485 serial board required)
 - W BACNET IP / PCOWEB serial board (advanced controller required)
- 10 Special coils / Protective treatments**
 - 0 Standard
 - B Pre-painted fins with epoxy painting
 - C Cataphoresis
 - I Hydrophilic
 - R Copper-copper
- 11 Outdoor finned coil heat exchanger protection**
 - 0 Absent
 - G Outdoor finned coil heat exchanger protection grille
- 12 Compressors options**
 - 0 Absent
 - 1 Power factor capacitors
 - 2 Soft starter
 - 3 Power factor capacitors + soft starter
- 13 Additional boards**
 - 0 Absent
 - 1 RS485 serial board (Carel / Modbus protocol)
 - 2 Clock board (advanced controller required)
 - 3 LON FTT10 serial board (advanced controller required)
- 14 Packing**
 - 1 Wooden cage
 - 2 Wooden crate

ACCESSORIES

RYKAMF Spring anti vibration shock mounts
RYMCL MyChiller Plus (RS485 serial board required)

RYMCM MyChiller Base (RS485 serial board required)
RYPAM Rubber anti vibration shock mounts

Total heat recovery multi-purpose units MCP

RATED TECHNICAL DATA

MCP			007	007M	009	009M	010
Power supply		V-ph-Hz	400 - 3N - 50	230 - 1 - 50	400 - 3N - 50	230 - 1 - 50	400 - 3N - 50
Cooling mode operation							
Cooling capacity	(1)	kW	7,56	7,53	9,63	9,52	11,2
Total power input	(1)	kW	2,35	2,44	2,96	3,06	3,45
EER	(1)		3,22	3,09	3,25	3,11	3,25
SEER	(2)		3,90	3,47	3,71	3,59	3,85
Water flow	(1)	l/h	1308	1303	1668	1648	1939
Water pressure drop	(1)	kPa	24	24	30	30	24
Available pressure head - LP pumps	(1)	kPa	142	144	122	124	121
Cooling mode operation and DHW in total recovery							
Cooling capacity	(3)	kW	6,43	7,19	9,03	9,00	10,7
Heating capacity	(3)	kW	8,79	9,66	12,1	12,1	14,1
Total power input	(3)	kW	2,47	2,59	3,19	3,24	3,63
COP HRE	(3)		6,15	6,49	6,61	6,51	6,83
Water flow user side	(3)	l/h	1113	1244	1563	1559	1847
Water pressure drop user side	(3)	kPa	18	22	27	27	22
Available pressure head user side - LP pumps	(3)	kPa	154	148	129	130	127
Water flow DHW side	(3)	l/h	1515	1663	2076	2080	2437
Water pressure drop DHW side	(3)	kPa	28	33	40	40	32
Available pressure head DHW side - LP pumps	(3)	kPa	130	122	93	93	86
Heating or DHW operation							
Heating capacity	(4)	kW	8,82	8,95	11,3	11,2	12,8
Total power input	(4)	kW	2,58	2,68	3,30	3,49	3,77
COP	(4)		3,42	3,34	3,42	3,21	3,4
SCOP	(2)		4,35	3,79	3,90	3,64	3,83
Heating energy efficiency class	(5)		A++	A+	A++	A+	A++
Water flow	(4)	l/h	1520	1542	1940	1931	2212
Water pressure drop	(4)	kPa	28	28	36	35	27
Available pressure head - LP pumps	(4)	kPa	138	134	111	111	107
General data							
Maximum current absorption		A	5	15	7	20	8
Star up current		A	32	76	46	97	52
Star up current with soft starter		A	16	44	20	59	23
Compressors / circuits					1 / 1		
Expansion vessel volume (User side / DHW)		dm ³			5 / 1		
Buffer tank volume		dm ³	30	30	30	30	30
Sound power level	(6)	dB(A)	72	72	75	75	75
Transport weight unit with pump and tank		kg	228	228	265	265	256
Operating weight unit with pump and full tank		kg	245	245	282	282	272

(1) Outdoor air temperature 35°C, water temperature 12°C / 7°C (EN14511:2013)

(2) η efficiency values for heating and cooling are respectively calculated by the following formulas: $[\eta = SCOP / 2,5 - F(1) - F(2)]$ e $[\eta = SEER / 2,5 - F(1) - F(2)]$. For further information, please refer to the technical document "ErP 2009/125/EC DIRECTIVE" in the catalogue introducing pages, or to the EN14825:2017 regulation.

(3) Cooling water temperature 12°C / 7°C, recovery water temperature 40°C / 45°C (EN14511:2013)

(4) Outdoor air temperature dry bulb 7°C / wet bulb 6°C, water temperature 40°C / 45°C (EN14511:2013)

(5) Seasonal energy efficiency class for LOW TEMPERATURE room heating under AVERAGE climatic conditions [EUROPEAN REGULATION No 811/2013]

(6) Sound power level measured according to ISO 9614

RATED TECHNICAL DATA

MCP			010M	013	013M	015	018
Power supply		V-ph-Hz	230 - 1 - 50	400 - 3N - 50	230 - 1 - 50	400 - 3N - 50	400 - 3N - 50
Cooling mode operation							
Cooling capacity	(1)	kW	11,0	13,5	13,3	15,7	19,4
Total power input	(1)	kW	3,56	4,19	4,28	5,11	6,77
EER	(1)		3,09	3,22	3,11	3,07	2,87
SEER	(2)		3,65	3,83	3,70	3,71	3,44
Water flow	(1)	l/h	1908	2341	2302	2717	3367
Water pressure drop	(1)	kPa	23	33	32	33	49
Available pressure head - LP pumps	(1)	kPa	123	143	145	130	131
Cooling mode operation and DWH in total recovery							
Cooling capacity	(3)	kW	10,5	12,8	12,6	15,4	18,6
Heating capacity	(3)	kW	14,1	17,1	17,0	20,4	25,3
Total power input	(3)	kW	3,78	4,48	4,61	5,30	7,03
COP HRE	(3)		6,48	6,67	6,42	6,75	6,23
Water flow user side	(3)	l/h	1807	2219	2180	2663	3217
Water pressure drop user side	(3)	kPa	21	30	29	32	45
Available pressure head user side - LP pumps	(3)	kPa	129	150	152	133	137
Water flow DHW side	(3)	l/h	2423	2941	2924	3515	4340
Water pressure drop DHW side	(3)	kPa	32	45	45	55	72
Available pressure head DHW side - LP pumps	(3)	kPa	88	111	111	78	92
Heating or DHW operation							
Heating capacity	(4)	kW	12,7	15,8	15,7	18,2	23,6
Total power input	(4)	kW	3,86	4,61	4,71	5,36	7,23
COP	(4)		3,29	3,43	3,33	3,4	3,26
SCOP	(2)		3,72	3,83	3,72	3,84	3,52
Heating energy efficiency class	(5)		A+	A++	A+	A++	A+
Water flow	(4)	l/h	2187	2726	2705	3128	4049
Water pressure drop	(4)	kPa	26	40	39	45	63
Available pressure head - LP pumps	(4)	kPa	107	128	128	106	112
General data							
Maximum current absorption		A	22	9	27	12	15
Star up current		A	108	64	150	74	99
Star up current with soft starter		A	66	28	82	34	45
Compressors / circuits					1 / 1		
Expansion vessel volume (User side / DHW)		dm ³			5 / 1		
Buffer tank volume		dm ³	30	30	30	30	50
Sound power level	(6)	dB(A)	75	75	75	75	78
Transport weight unit with pump and tank		kg	256	265	265	270	393
Operating weight unit with pump and full tank		kg	272	282	282	287	426

(1) Outdoor air temperature 35°C, water temperature 12°C / 7°C (EN14511:2013)

(2) η efficiency values for heating and cooling are respectively calculated by the following formulas: $[\eta = SCOP / 2,5 - F(1) - F(2)]$ e $[\eta = SEER / 2,5 - F(1) - F(2)]$. For further information, please refer to the technical document "ErP 2009/125/EC DIRECTIVE" in the catalogue introducing pages, or to the EN14825:2017 regulation.

(3) Cooling water temperature 12°C / 7°C, recovery water temperature 40°C / 45°C (EN14511:2013)

(4) Outdoor air temperature dry bulb 7°C / wet bulb 6°C, water temperature 40°C / 45°C (EN14511:2013)

(5) Seasonal energy efficiency class for LOW TEMPERATURE room heating under AVERAGE climatic conditions [EUROPEAN REGULATION No 811/2013]

(6) Sound power level measured according to ISO 9614

Total heat recovery multi-purpose units MCP

RATED TECHNICAL DATA

MCP			T18	T18 M	T22	T22 M	T24
Power supply		V-ph-Hz	400 - 3N - 50	230 - 1 - 50	400 - 3N - 50	230 - 1 - 50	400 - 3N - 50
Cooling mode operation							
Cooling capacity	(1)	kW	18,6	18,4	21,4	21,2	26,2
Total power input	(1)	kW	5,97	6,22	6,98	7,22	8,68
EER	(1)		3,12	2,96	3,07	2,94	3,02
SEER	(2)		3,86	3,59	3,86	3,71	4,24
Water flow	(1)	l/h	3227	3191	3714	3669	4536
Water pressure drop	(1)	kPa	45	45	41	41	35
Available pressure head - LP pumps	(1)	kPa	135	137	132	135	129
Cooling mode operation and DHW in total recovery							
Cooling capacity	(3)	kW	17,3	17,3	20,6	20,3	25,6
Heating capacity	(3)	kW	23,5	23,6	27,5	27,5	34,0
Total power input	(3)	kW	6,49	6,55	7,25	7,54	8,86
COP HRE	(3)		6,29	6,24	6,62	6,34	6,74
Water flow user side	(3)	l/h	2999	3000	3560	3512	4427
Water pressure drop user side	(3)	kPa	40	40	38	37	33
Available pressure head user side - LP pumps	(3)	kPa	144	145	138	140	132
Water flow DHW side	(3)	l/h	4040	4050	4728	4728	5869
Water pressure drop DHW side	(3)	kPa	63	63	59	59	50
Available pressure head DHW side - LP pumps	(3)	kPa	104	103	95	97	84
Heating or DHW operation							
Heating capacity	(4)	kW	22,3	22,5	25,5	25,2	30,6
Total power input	(4)	kW	6,82	7,05	7,82	8,08	9,22
COP	(4)		3,27	3,19	3,26	3,12	3,32
SCOP	(2)		3,89	3,66	3,81	3,71	4,00
Heating energy efficiency class	(5)		A++	A+	A++	A+	A++
Water flow	(4)	l/h	3839	3871	4391	4339	5278
Water pressure drop	(4)	kPa	57	58	51	50	42
Available pressure head - LP pumps	(4)	kPa	121	121	117	118	109
General data							
Maximum current absorption		A	13	39	15	44	18
Star up current		A	53	117	59	130	73
Star up current with soft starter		A	26	78	30	88	37
Compressors / circuits					2 / 1		
Expansion vessel volume (User side / DHW)		dm ³			5 / 1		
Buffer tank volume		dm ³	50	50	50	50	50
Sound power level	(6)	dB(A)	78	78	78	78	78
Transport weight unit with pump and tank		kg	395	395	388	388	394
Operating weight unit with pump and full tank		kg	428	428	415	415	420

(1) Outdoor air temperature 35°C, water temperature 12°C / 7°C (EN14511:2013)

(2) η efficiency values for heating and cooling are respectively calculated by the following formulas: $[\eta = SCOP / 2,5 - F(1) - F(2)]$ e $[\eta = SEER / 2,5 - F(1) - F(2)]$. For further information, please refer to the technical document "ErP 2009/125/EC DIRECTIVE" in the catalogue introducing pages, or to the EN14825:2017 regulation.

(3) Cooling water temperature 12°C / 7°C, recovery water temperature 40°C / 45°C (EN14511:2013)

(4) Outdoor air temperature dry bulb 7°C / wet bulb 6°C, water temperature 40°C / 45°C (EN14511:2013)

(5) Seasonal energy efficiency class for LOW TEMPERATURE room heating under AVERAGE climatic conditions [EUROPEAN REGULATION No 811/2013]

(6) Sound power level measured according to ISO 9614

RATED TECHNICAL DATA

MCP			T24 M	027	T30	032	040
Power supply		V-ph-Hz	230 - 1 - 50	400 - 3N - 50	400 - 3N - 50	400 - 3N - 50	400 - 3N - 50
Cooling mode operation							
Cooling capacity	(1)	kW	25,8	27,3	32,0	34,2	40,1
Total power input	(1)	kW	9,19	9,36	10,5	11,4	14,2
EER	(1)		2,81	2,92	3,05	3,00	2,82
SEER	(2)		3,97	3,57	3,98	3,68	3,44
Water flow	(1)	l/h	4464	4715	5523	5909	6934
Water pressure drop	(1)	kPa	34	38	34	38	43
Available pressure head - LP pumps	(1)	kPa	131	122	108	143	128
Cooling mode operation and DWH in total recovery							
Cooling capacity	(3)	kW	25,2	27,1	30,4	32,7	39,4
Heating capacity	(3)	kW	34,1	36,0	40,8	43,5	53,0
Total power input	(3)	kW	9,41	9,35	10,9	11,3	14,3
COP HRE	(3)		6,30	6,75	6,54	6,73	6,46
Water flow user side	(3)	l/h	4353	4689	5259	5646	6805
Water pressure drop user side	(3)	kPa	32	37	31	35	42
Available pressure head user side - LP pumps	(3)	kPa	134	123	117	149	131
Water flow DHW side	(3)	l/h	5884	6206	7042	7495	9130
Water pressure drop DHW side	(3)	kPa	51	56	47	53	69
Available pressure head DHW side - LP pumps	(3)	kPa	85	72	59	113	80
Heating or DHW operation							
Heating capacity	(4)	kW	30,3	31,7	37,3	40,3	47,7
Total power input	(4)	kW	9,44	9,32	11,2	12,0	14,6
COP	(4)		3,21	3,4	3,4	3,36	3,27
SCOP	(2)		3,87	3,72	3,94	3,68	3,60
Heating energy efficiency class	(5)		A++	A+	A++	A+	A+
Water flow	(4)	l/h	5234	5472	6439	6952	8230
Water pressure drop	(4)	kPa	41	45	40	47	57
Available pressure head - LP pumps	(4)	kPa	109	105	85	129	106
General data							
Maximum current absorption		A	54	19	23	23	29
Star up current		A	177	127	86	167	198
Star up current with soft starter		A	109	57	46	68	86
Compressors / circuits			2 / 1	1 / 1	2 / 1	1 / 1	1 / 1
Expansion vessel volume (User side / DHW)		dm ³	5 / 1	5 / 1	8 / 1	8 / 1	8 / 1
Buffer tank volume		dm ³	50	50	125	125	125
Sound power level	(6)	dB(A)	78	78	78	78	78
Transport weight unit with pump and tank		kg	394	398	525	525	528
Operating weight unit with pump and full tank		kg	420	435	632	632	635

(1) Outdoor air temperature 35°C, water temperature 12°C / 7°C (EN14511:2013)

(2) η efficiency values for heating and cooling are respectively calculated by the following formulas: $[\eta = SCOP / 2,5 - F(1) - F(2)]$ e $[\eta = SEER / 2,5 - F(1) - F(2)]$. For further information, please refer to the technical document "ErP 2009/125/EC DIRECTIVE" in the catalogue introducing pages, or to the EN14825:2017 regulation.

(3) Cooling water temperature 12°C / 7°C, recovery water temperature 40°C / 45°C (EN14511:2013)

(4) Outdoor air temperature dry bulb 7°C / wet bulb 6°C, water temperature 40°C / 45°C (EN14511:2013)

(5) Seasonal energy efficiency class for LOW TEMPERATURE room heating under AVERAGE climatic conditions [EUROPEAN REGULATION No 811/2013]

(6) Sound power level measured according to ISO 9614

Total heat recovery multi-purpose units MCP

DIMENSIONAL DRAWINGS

MCP 07 - 15

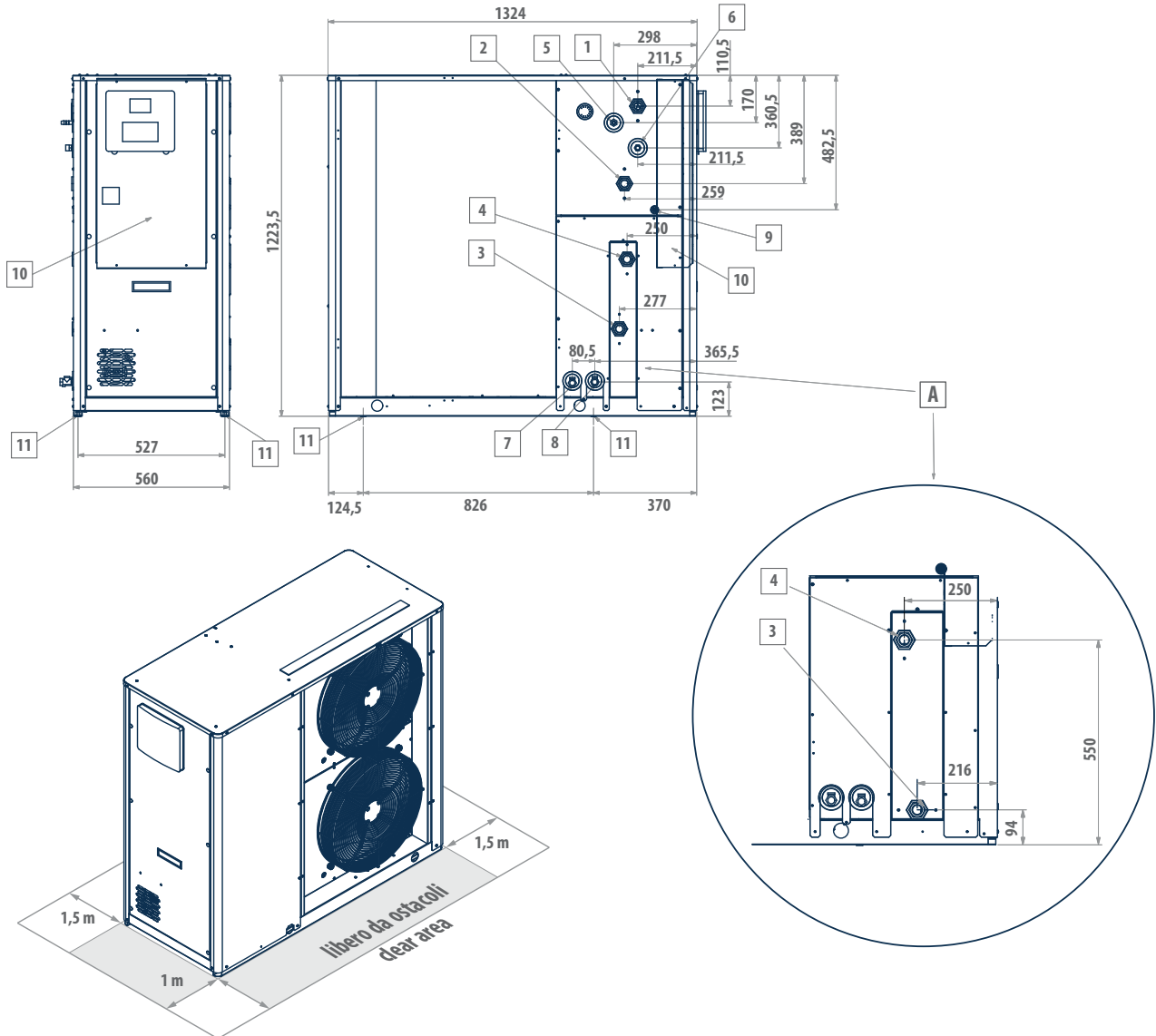

LEGEND

1	System water inlet 1" 1/4 female
2	DHW inlet 1" 1/4 female
3	System water outlet 1" 1/4 female
4	DHW outlet 1" 1/4 female
5	Safety valve discharge outlet provided with rubber ring holder
6	Water supply 1/2" male (optional tap)
7	System water outlet 1/2" female
8	DHW outlet 1/2" female
9	Power supply \varnothing 28 mm
10	Electric control board
11	Fastening points for vibration dampers
A	Version with EC pump

DIMENSIONAL DRAWINGS

MCP 18 - 27

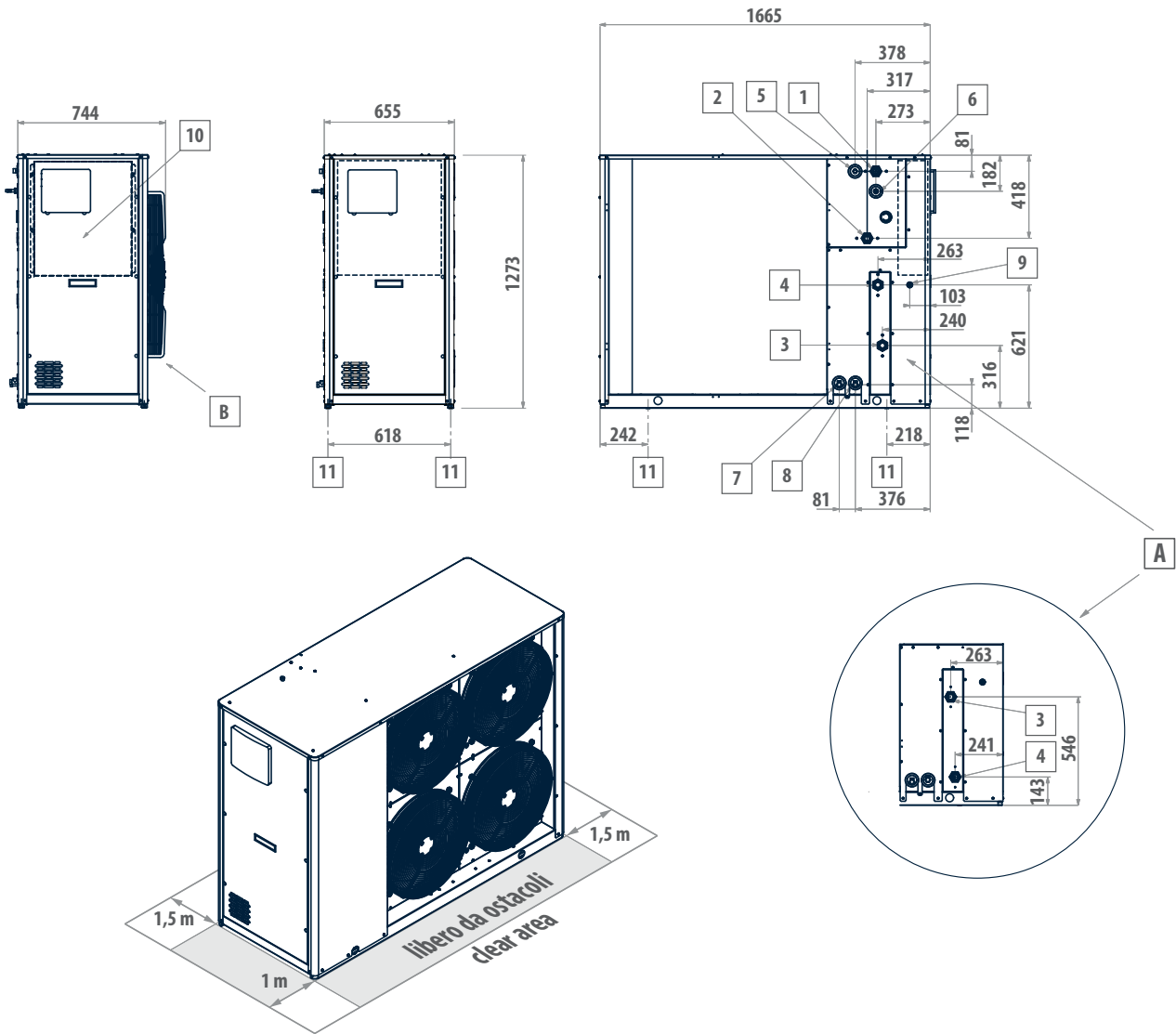

LEGEND

1	System water inlet 1" 1/4 female
2	DHW inlet 1" 1/4 female
3	System water outlet 1" 1/4 female
4	DHW outlet 1" 1/4 female
5	Safety valve discharge outlet provided with rubber ring holder
6	Water supply 1/2" male (optional tap)
7	System water outlet 1/2" female
8	DHW outlet 1/2" female
9	Power supply \varnothing 28 mm
10	Electric control board
11	Fastening points for vibration dampers
A	Version with EC pump
B	EC fan view

Total heat recovery multi-purpose units MCP

DIMENSIONAL DRAWINGS

MCP 18T - 24T

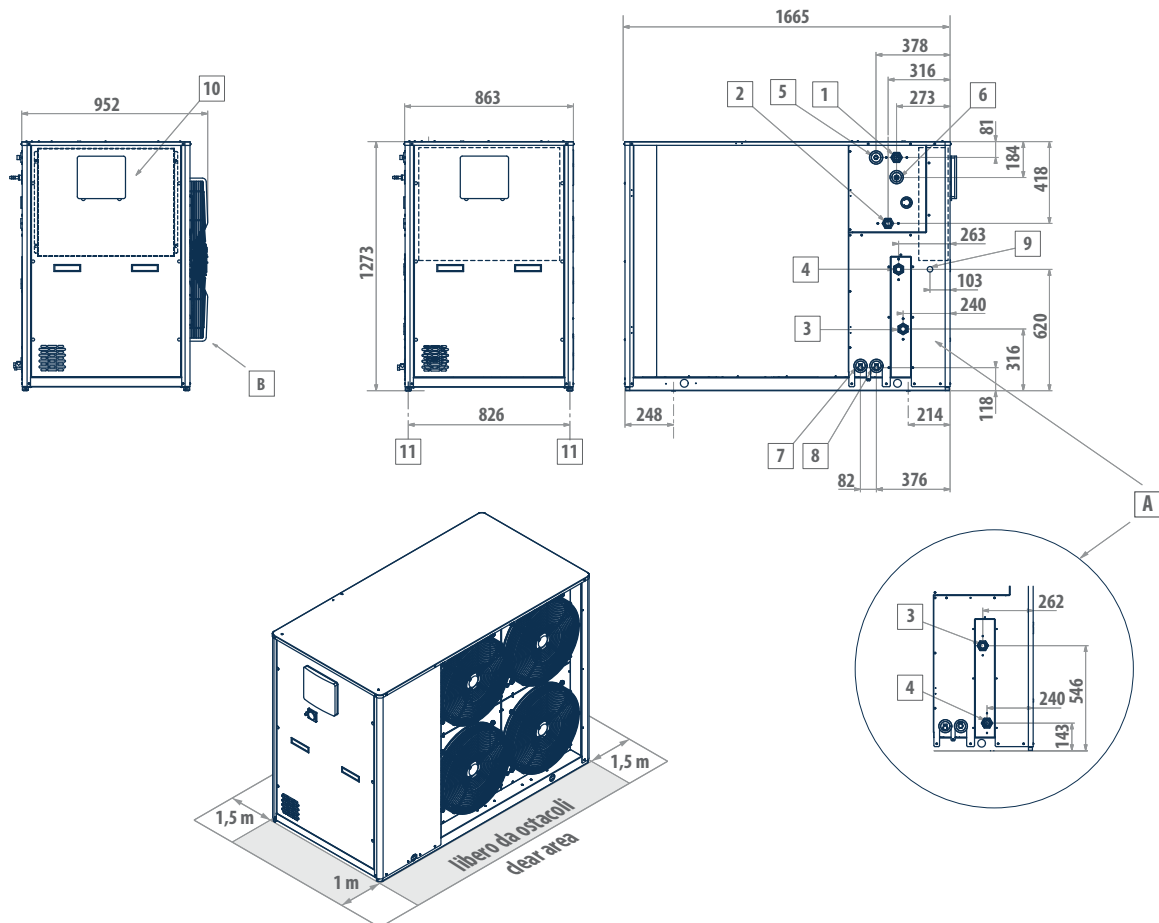

LEGEND

1	System water inlet 1" 1/4 female
2	DHW inlet 1" 1/4 female
3	System water outlet 1" 1/4 female
4	DHW outlet 1" 1/4 female
5	Safety valve discharge outlet provided with rubber ring holder
6	Water supply 1/2" male (optional tap)
7	System water outlet 1/2" female
8	DHW outlet 1/2" female
9	Power supply \varnothing 28 mm
10	Electric control board
11	Fastening points for vibration dampers
A	Version with EC pump
B	EC fan view

DIMENSIONAL DRAWINGS

MCP 32 - 40 - 30T

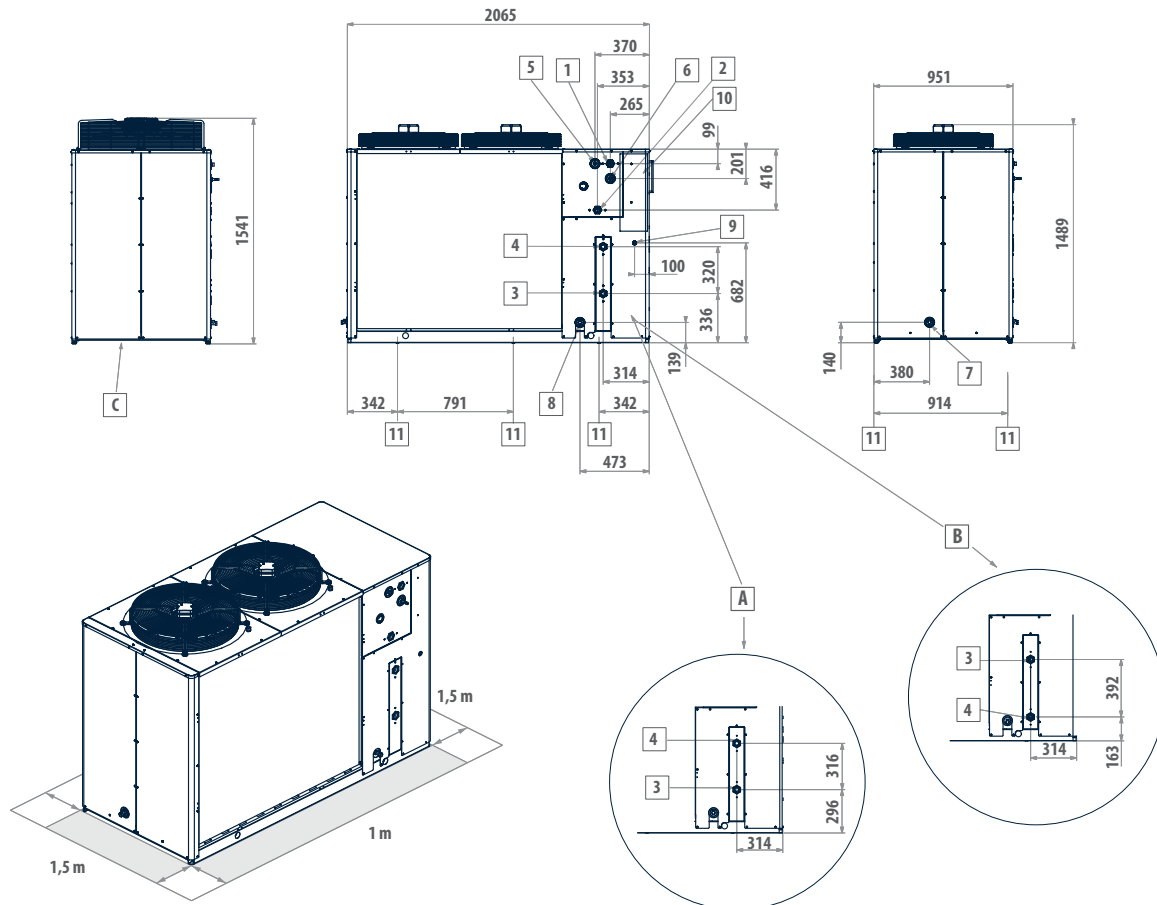

LEGEND

1	System water inlet 1" 1/4 female
2	DHW inlet 1" 1/4 female
3	System water outlet 1" 1/4 female
4	DHW outlet 1" 1/4 female
5	Safety valve discharge outlet provided with rubber ring holder
6	Water supply 1/2" male (optional tap)
7	System water outlet 1/2" female
8	DHW outlet 1/2" female
9	Power supply \varnothing 28 mm
10	Electric control board
11	Fastening points for vibration dampers
A	Version with EC pump, models 32 - 40
B	Version with EC pump, model T30
C	EC fan view

Total heat recovery multi-purpose units LCP

Outdoor packaged air-water unit

LCP 52 - 314 kW



PLUS

- » Total heat recovery in two-pipe and four-pipe systems
- » High efficiency under part load conditions
- » Production of chilled water up to an air temperature of 51 °C
- » Smart Defrost System always able to guarantee continuity in operation
- » Built-in hydronic unit

The total recovery LCP heat pumps have been designed for the cooling and the heating of the water destined to air-conditioning and domestic systems in residential, commercial or industrial buildings.

Heating, cooling, domestic hot water = one single system to meet all kinds of needs.

LCP multi-purpose units are air conditioning and domestic hot water (DHW) production units conceived for both residential and industrial use and designed to operate 24 hours a day. They cover a wide range of heating capacities, from 52 to 314 kW, guaranteeing a high thermodynamic efficiency and broad configurability, both in terms of accessories and cooling circuits.

All units of the LCP series, regardless of size, can be also made in a low-noise configuration L, in which the compressors and compressor compartment are covered with sound-deadening material and the unit is specially dimensioned so as to be compatible with a reduced fan speed.

As for units with refrigerating capacity lower than 100 kW, LCP presents a solution with a double compressor divided into two independent thermodynamic circuits to always assure the unit operation.

As for units with cooling power higher than 100 kW, 4 compressors divided in two thermodynamic circuits are available in order to supply the unit power in four steps, perfectly adjusting it to the actual heat load of the system and to reduce inrush current.

LCP units can be coupled with both 2- and 4-pipe systems, the letter "P" indicates heat pump for 4-pipe systems and the letter "M" indicates multifunctional heat pump for 2-pipe systems.

In both versions, the machine uses the total heat recovery, when a request for contemporary production of cold water (cooling) and hot water (heating/DHW production) is needed.

The unit recovers the condensation heat of the cooling system that would otherwise be ejected into the atmosphere.

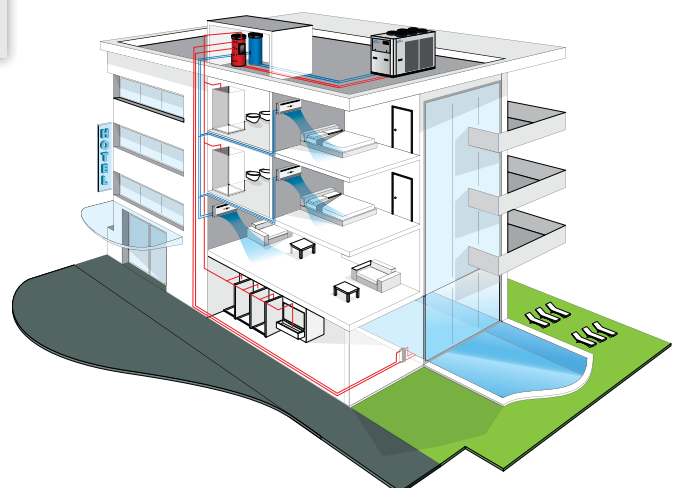

MAIN COMPONENTS

Refrigerating circuits

Thanks to the presence of two independent thermodynamic circuits, the LCP M is capable of producing hot water for heating while simultaneously carrying out a defrost cycle or guaranteeing the replenishment of domestic hot water.

Heat exchanger

Hydrophilic finned block heat exchangers are installed; these break down the drops of water into particles and reduce the obstruction of the space between one fin and another caused by ice build-up. Thanks to a lower surface tension, the water tends to slide and precipitate by gravity, preventing the formation of frost at low temperatures.



Fans

4/6/8-pole axial-type fans with air-foil-shaped blades made of hybrid plastic/aluminium material, statically and dynamically balanced in two planes, fitted with a protective grille and mounted with rubber vibration dampers placed in between. Option to select the condensation pressure-switch control with variation of the air-flow rate through electronic switching operated fans, to operate in cooling mode at low temperatures (up to -15 °C)

Compressors

The scroll compressor today represents the best solution in terms of reliability and efficiency in the range of capacities up to 200 kW per circuit and the best solution in terms of sound power emitted. The use of scroll compressors makes it possible to use low-viscosity oils which, compared to solutions with oil at a high viscosity level, reduce thermal resistance at the evaporator with increases in the evaporation temperature of over 1.5 °C (more than a 5.5% gain in terms of EER) compared to alternative solutions.



Electronic microprocessor control

LCP units are supplied with an Advanced microprocessor controller. In addition to the functions described below, this microprocessor offers the option of custom software features to ensure optimal satisfaction of all system requirements, including control of the unit with step-control or cascade logic.

As regards remote communication options, the controls are configured for a connection to advanced BMS systems.

CONFIGURATOR

The models are completely configurable by selecting the version and the options. To the right is shown an example of configuration.

Version	Fields	1	2	3	4	5	6	7	8	9	10	11	12
LCP144PL		0	C	1	0	1	C	P	1	0	0	G	3

To verify the compatibility of the options, use the selection software or the price list.

AVAILABLE VERSIONS

2-pipe system versions

LCP.MS Standard execution
LCP-ML Low noise execution

4-pipe system versions

LCP.PS Standard execution
LCP-PL Low noise execution

CONFIGURATION OPTIONS

1 Power supply

- 0 400 V - 3 N - 50 Hz
- 1 400 V - 3 - 50 Hz
- 2 400 V - 3 N - 50 Hz + magnetic breakers
- 3 400 V - 3 - 50 Hz + magnetic breakers

2 Onboard controller and expansion valve

- C Advanced + mechanical expansion valve

3 User side water pump

- 0 Absent
- 1 LP pump + expansion vessel
- 2 HP pump + expansion vessel
- 3 Double pump LP parallel operation and expansion vessel (advanced controller required)
- 4 Double pump HP parallel operation and expansion vessel (advanced controller required)
- 5 LP run and standby double pump + expansion vessel
- 6 HP run and standby double pump + expansion vessel

4 Water buffer tank

- 0 Absent
- R Selected recovery side
- S Selected user side

5 Recovery water pump

- 0 Absent
- 1 LP pump + expansion vessel
- 2 HP pump + expansion vessel
- 3 Double pump LP parallel operation and expansion vessel (advanced controller required)
- 4 Double pump HP parallel operation and expansion vessel (advanced controller required)
- 5 LP run and standby double pump + expansion vessel
- 6 HP run and standby double pump + expansion vessel

6 Air flow modulation

- C Condensation control by phase-cut fans
- E Condensation control performed by EC fans

7 Antifreezing kit

- 0 Absent
- E Plate exchanger
- P Plate exchanger and water pump
- S Plate exchanger, water pump and inertial tank

8 Remote communication

- 0 Absent
- 1 RS485 serial board (Carel / Modbus protocol)
- 2 LON FTT10 serial board (advanced controller required)
- 3 GSM modem board (advanced controller required)
- 4 BACNET IP / PCOWEB serial board + supervision software Gweb (advanced controller required)
- 5 BACNET IP / PCOWEB serial board + clock board + supervision software Gweb (advanced controller required)

9 Special coils / Protective treatments

- 0 Standard
- B Pre-painted fins with epoxy painting
- C Cataphoresis
- R Copper-copper

10 Packing

- 0 Standard
- 1 Wooden cage
- 2 Wooden crate

11 Anti vibration shock mounts

- 0 Absent
- G Rubber anti vibration shock mounts
- M Spring anti vibration shock mounts

12 Remote control

- 0 Absent
- 3 Remote simplified user panel for advanced controller

ACCESSORIES

A	Power factor capacitors	G	Filter isolation valves kit (solenoid valve and isolation valve)
B	Soft starter	H	Directives reference other than "2014/68/UE - PED"
C	ON/OFF status of the compressors	I	Unit lifting pipes
D	Two pairs of Victaulic joints	L	Outdoor finned coil heat exchanger protection grille
E	Set point compensation outdoor temperature probe	M	Outdoor finned coil heat exchanger protection filters
F	Refrigerant pressure gauges		

Total heat recovery multi-purpose units LCP

AVAILABLE VERSIONS

LCP M - 2-pipe systems

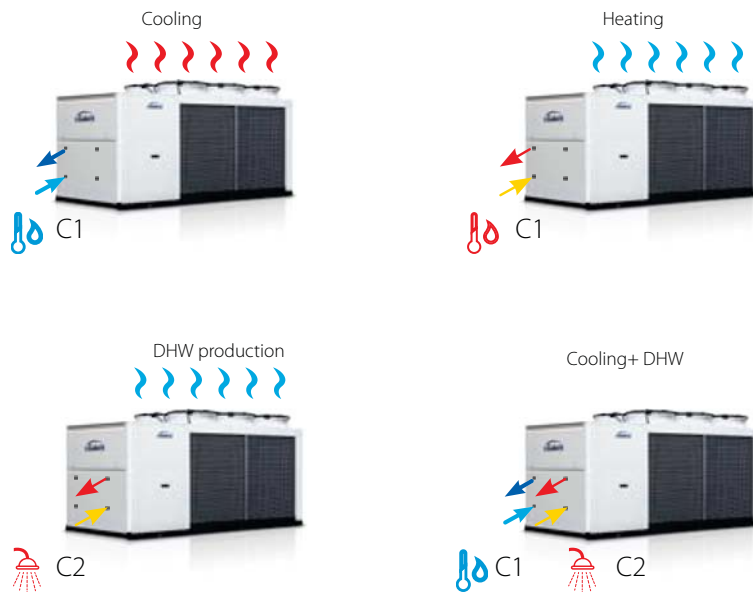

Operating modes available for an LCP M unit which interfaces with a 2-pipe system.

C1 Hydraulic circuit manages winter heating and summer air-conditioning while the C2 one is used for the production of DHW, ensuring this function 365 days per year.

In case of simultaneous production of cold (C1) and high-temperature water for domestic use (C2), the machine is able to recover all the condensation heat on the refrigerant for the production of DHW.

LCP P - 4-pipe systems

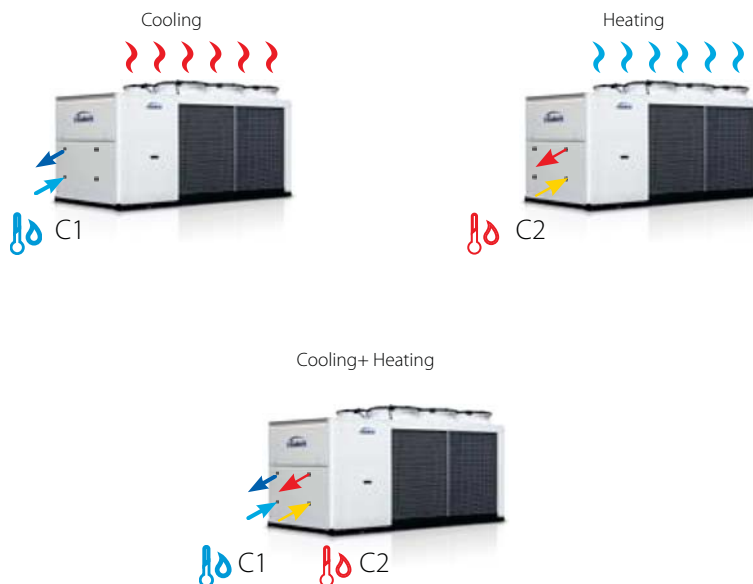

Operating modes available for an LCP P unit which interfaces with a 4-pipe air conditioning system.

In this kind of systems, it is possible to request air-conditioning and heating at the same time. For this reason, C1 and C2 hydraulic circuits respectively produce cold and hot water.

In case of simultaneous operation of C1 and C2 hydraulic circuits, the condensation heat of the cooling system is totally recovered for the production of hot water.

Operating modes of the LCP M version



Cooling

In the "Chiller" mode the LCP M multifunctional unit chills water to cool a room on the user side, dissipating the condensation heat in air by means of a finned block condenser.



Heating

In the "Heat Pump" mode the LCP M unit heats the water in the condenser to provide heating on the user side, absorbing the evaporative cooling capacity in air by means of a finned block heat exchanger.



Hot water production (for sanitary use-DHW)

In the "Production of High-temperature Hot Water for sanitary use (DHW)" mode the LCP M multifunctional unit heats water in the second condenser, absorbing the evaporative cooling capacity in air by means of a finned block heat exchanger.



simultaneous

Cooling and hot water production through total recovery

In the "Chiller + DHW" mode the LCP M multifunctional unit can produce chilled water with the simultaneous production of high-temperature hot water for sanitary use, thanks to total heat recovery.



simultaneous

Hot water production (for example for sanitary use) simultaneously with heating

In the "Simultaneous DHW Production and Heating" mode the LCP M multifunctional unit heats water in parallel, optimally exploiting the complete independence of its thermodynamic circuits. Capacity is equally divided between the two circuits.

The solution to the problem of defrosting

During the wintertime period, especially with temperatures ranging between -3 °C and +3 °C, the high ambient relative humidity causes the formation of water condensation around the exchanger fins.

Since the exchanger is at a lower temperature than the outdoor air, the water in contact with it ends up hindering the heat exchange necessary for the system to work correctly.

A defrost cycle is a temporary reversal of the thermodynamic cycle which switches the unit into the summer mode and melts the ice present between fins.

This phase is obviously problematic, since the cooling cycle warms up the exchanger by drawing heat from the room that was previously being heated. The circuit that is defrosting will draw heat on the user side (that is, not on the DHW side) if the unit is LCP M, and will heat on the hot water user side if the unit is LCP P.

Separate defrosting



The LCP unit reduces this problem with the following technical innovations:

- The two thermodynamic circuits in the LCP M and LCP P are completely independent and while one defrosts, the other circuit is able to ensure continuity in the unit's operation, with practically no thermal discomfort for the user.
- Hydrophilic coils are installed; these break down the drops of water into particles and reduce the obstruction of the space between one fin and another caused by ice build-up. Thanks to a lower surface tension, the water tends to slide and precipitate by gravity, preventing the formation of frost at low temperatures.
- The software which manages the defrost cycle minimizes the time it takes to complete it and only acts when it is really necessary. The fans are pushed to their maximum capacity at just the right time, that is, when the ice is no longer stuck to the fins, and mechanically ejects it from the heat exchanger.

Total heat recovery multi-purpose units LCP

LCP MS RATED TECHNICAL DATA OF MODELS FOR 2-PIPE SYSTEMS + DHW

LCP MS			41	51	61	71	81	94	104	124
Power supply		V-ph-Hz	400 - 3N - 50							
Cooling mode operation										
Cooling capacity	(1)(E)	kW	51,4	56,1	67,3	73,8	82,4	102	111	134
Total power input	(1)(E)	kW	16,2	18,3	20,8	23,4	27,0	32,7	37,1	44,1
EER	(1)(E)		3,17	3,07	3,24	3,15	3,06	3,10	3,00	3,04
Water flow	(1)	l/h	8874	9695	11616	12743	14227	17571	19157	23115
Water pressure drop	(1)(E)	kPa	29	34	34	41	32	37	43	45
Cooling mode operation and DHW in total recovery										
Cooling capacity	(2)(E)	kW	46,2	50,6	60,1	66,1	78,8	92,5	101	119
Heating capacity	(3)(E)	kW	61,5	67,9	79,7	88,3	104	123	136	158
Total power input	(4)(E)	kW	16,1	18,1	20,6	23,3	26,0	32,1	36,2	41,4
COP HRE	(4)(E)		6,67	6,54	6,77	6,61	7,01	6,71	6,53	6,67
Water flow user side	(2)	l/h	8874	9695	11616	12743	14227	17571	19157	23115
Water pressure drop user side	(2)(E)	kPa	29	34	34	41	32	37	43	45
Water flow DHW side	(3)	l/h	9744	10724	12702	13941	15534	19118	21122	24802
Water pressure drop DHW side	(3)(E)	kPa	35	42	41	49	39	44	52	52
Heating or DHW operation										
Heating capacity	(5)(E)	kW	56,6	62,4	73,8	81,0	89,8	111	123	144
Total power input	(5)(E)	kW	16,8	18,7	21,9	24,4	26,5	33,4	37,2	45,6
COP	(5)(E)		3,37	3,32	3,37	3,32	3,38	3,33	3,30	3,16
Water flow	(5)	l/h	9744	10724	12702	13941	15534	19118	21122	24802
Water pressure drop	(5)(E)	kPa	35	42	41	49	39	44	52	52
General data										
Maximum current absorption		A	41	44	51	55	66	81	87	96
Star up current		A	159	162	185	183	191	194	198	220
Star up current with soft starter		A	88	101	111	124	139	122	137	146
Compressors / circuits			2 / 2	2 / 2	2 / 2	2 / 2	2 / 2	4 / 2	4 / 2	4 / 2
Expansion vessel volume		dm ³	8	8	8	8	8	8	8	24
Buffer tank volume		dm ³	200	200	220	220	220	340	340	600
Sound power level	(6)(E)	dB(A)	81	81	82	82	83	83	83	84
Transport weight unit with pump and tank		kg	882	690	800	810	850	1190	1210	1530
Operating weight unit with pump and full tank		kg	1082	1082	1082	1082	1082	1082	1082	1082

- (1) Outdoor air temperature 35°C, water temperature 12°C / 7°C (EN14511:2013)
 (2) Cooling water temperature 7°C, water flow rate same as in cooling mode
 (3) Recovery water temperature 45°C, water flow rate same as in cooling mode
 (4) Cooling water temperature 7°C, recovery water temperature 45°C
 (5) Outdoor air temperature dry bulb 7°C / wet bulb 6°C, water temperature 40°C / 45°C (EN14511:2013)
 (6) Sound power level measured according to ISO 9614
 (E) EUROVENT certified data

LCP MS RATED TECHNICAL DATA OF MODELS FOR 2-PIPE SYSTEMS + DHW

LCP MS			144	164	194	214	244	274	294	324
Power supply		V-ph-Hz	400 - 3N - 50							
Cooling mode operation										
Cooling capacity	(1)(E)	kW	147	166	193	220	238	263	298	312
Total power input	(1)(E)	kW	49,2	55,6	66,9	75,7	84,2	92,4	103	117
EER	(1)(E)		2,99	2,98	2,87	2,90	2,81	2,85	2,88	2,68
Water flow	(1)	l/h	25411	28617	33237	37885	40949	45370	51321	53968
Water pressure drop	(1)(E)	kPa	54	49	46	59	58	39	48	63
Cooling mode operation and DWH in total recovery										
Cooling capacity	(2)(E)	kW	130	150	185	208	230	253	287	304
Heating capacity	(3)(E)	kW	175	200	244	276	304	334	379	407
Total power input	(4)(E)	kW	46,8	52,6	61,5	72,2	78,4	85,2	96,2	108
COP HRE	(4)(E)		6,51	6,63	6,97	6,69	6,81	6,87	6,91	6,59
Water flow user side	(2)	l/h	25411	28617	33237	37885	40949	45370	51321	53968
Water pressure drop user side	(2)(E)	kPa	54	49	46	59	58	39	48	63
Water flow DHW side	(3)	l/h	27348	31445	35879	42793	45279	51196	57519	59230
Water pressure drop DHW side	(3)(E)	kPa	63	59	54	75	71	60	73	76
Heating or DHW operation										
Heating capacity	(5)(E)	kW	159	182	209	248	263	296	333	343
Total power input	(5)(E)	kW	50,6	56,3	65,3	74,6	80,6	88,6	99,3	110
COP	(5)(E)		3,13	3,23	3,19	3,31	3,26	3,34	3,35	3,11
Water flow	(5)	l/h	27348	31445	35879	42793	45279	51196	57519	59230
Water pressure drop	(5)(E)	kPa	63	59	54	75	71	60	73	76
General data										
Maximum current absorption		A	105	126	148	167	190	215	229	242
Star up current		A	222	241	307	318	382	398	464	472
Star up current with soft starter		A	163	189	245	256	317	333	381	389
Compressors / circuits			4 / 2							
Expansion vessel volume		dm ³	24	24	24	24	24	24	24	24
Buffer tank volume		dm ³	600	600	600	600	600	765	765	765
Sound power level	(6)(E)	dB(A)	84	86	86	87	87	87	88	88
Transport weight unit with pump and tank		kg	1550	1690	1890	1890	1910	2260	2290	2320
Operating weight unit with pump and full tank		kg	1082	1082	1082	1082	1082	1082	1082	1082

- (1) Outdoor air temperature 35°C, water temperature 12°C / 7°C (EN14511:2013)
- (2) Cooling water temperature 7°C, water flow rate same as in cooling mode
- (3) Recovery water temperature 45°C, water flow rate same as in cooling mode
- (4) Cooling water temperature 7°C, recovery water temperature 45°C
- (5) Outdoor air temperature dry bulb 7°C / wet bulb 6°C, water temperature 40°C / 45°C (EN14511:2013)
- (6) Sound power level measured according to ISO 9614
- (E) EUROVENT certified data

Total heat recovery multi-purpose units LCP

LCP ML RATED TECHNICAL DATA OF MODELS FOR 2-PIPE SYSTEMS + DHW

LCP ML			41	51	61	71	81	94	104	124
Power supply		V-ph-Hz	400 - 3N - 50							
Cooling mode operation										
Cooling capacity	(1)(E)	kW	48,0	52,1	64,7	70,4	78,3	97,6	105	127
Total power input	(1)(E)	kW	16,4	18,8	20,9	24,0	28,1	33,5	38,3	45,0
EER	(1)(E)		3,01	2,85	3,10	2,93	2,80	2,93	2,75	2,82
Water flow	(1)	l/h	8265	8961	11172	12153	13513	16855	18189	21904
Water pressure drop	(1)(E)	kPa	18	21	32	38	30	34	39	41
Cooling mode operation and DHW in total recovery										
Cooling capacity	(2)(E)	kW	46,4	50,8	60,3	66,3	76,5	92,8	102	119
Heating capacity	(3)(E)	kW	61,6	68,0	79,9	88,5	101	123	136	158
Total power input	(4)(E)	kW	16,0	18,1	20,6	23,3	26,0	32,1	36,1	41,3
COP HRE	(4)(E)		6,74	6,55	6,79	6,63	6,83	6,73	6,57	6,71
Water flow user side	(2)	l/h	8265	8961	11172	12153	13513	16855	18189	21904
Water pressure drop user side	(2)(E)	kPa	18	21	32	38	30	34	39	41
Water flow DHW side	(3)	l/h	9527	10446	12436	13780	15388	18720	20473	24392
Water pressure drop DHW side	(3)(E)	kPa	23	28	40	48	38	42	49	50
Heating or DHW operation										
Heating capacity	(5)(E)	kW	55,4	60,7	72,0	79,8	89,0	109	119	141
Total power input	(5)(E)	kW	15,8	17,8	20,2	22,7	25,6	31,5	35,2	42,9
COP	(5)(E)		3,59	3,53	3,56	3,52	3,48	3,54	3,48	3,29
Water flow	(5)	l/h	9527	10446	12436	13780	15388	18720	20473	24392
Water pressure drop	(5)(E)	kPa	23	28	40	48	38	42	49	50
General data										
Maximum current absorption		A	41	44	51	55	66	81	87	96
Star up current		A	159	162	185	183	191	194	198	220
Star up current with soft starter		A	88	101	111	124	139	122	137	146
Compressors / circuits			2 / 2	2 / 2	2 / 2	2 / 2	2 / 2	4 / 2	4 / 2	4 / 2
Expansion vessel volume		dm ³	8	8	8	8	8	8	8	24
Buffer tank volume		dm ³	200	200	220	220	220	340	340	600
Sound power level	(6)(E)	dB(A)	75	75	77	77	78	77	77	79
Transport weight unit with pump and tank		kg	892	700	810	820	860	1210	1230	1550
Operating weight unit with pump and full tank		kg	1092	1102	1260	1270	1310	1860	1880	2425

- (1) Outdoor air temperature 35°C, water temperature 12°C / 7°C (EN14511:2013)
 (2) Cooling water temperature 7°C, water flow rate same as in cooling mode
 (3) Recovery water temperature 45°C, water flow rate same as in cooling mode
 (4) Cooling water temperature 7°C, recovery water temperature 45°C
 (5) Outdoor air temperature dry bulb 7°C / wet bulb 6°C, water temperature 40°C / 45°C (EN14511:2013)
 (6) Sound power level measured according to ISO 9614
 (E) EUROVENT certified data

LCP ML RATED TECHNICAL DATA OF MODELS FOR 2-PIPE SYSTEMS + DHW

LCP ML			144	164	194	214	244	274	294	324
Power supply		V-ph-Hz	400 - 3N - 50							
Cooling mode operation										
Cooling capacity	(1)(E)	kW	138	156	187	209	226	258	291	303
Total power input	(1)(E)	kW	51,2	57,1	67,4	77,0	86,7	92,7	105	119
EER	(1)(E)		2,69	2,59	2,78	2,82	2,73	2,79	2,79	2,55
Water flow	(1)	l/h	23786	26763	32255	35917	38875	44458	50140	52308
Water pressure drop	(1)(E)	kPa	48	30	44	55	29	38	46	60
Cooling mode operation and DWH in total recovery										
Cooling capacity	(2)(E)	kW	131	150	180	204	228	252	283	308
Heating capacity	(3)(E)	kW	175	200	238	272	302	334	375	411
Total power input	(4)(E)	kW	46,7	52,6	61,6	72,1	78,8	85,5	96,5	108
COP HRE	(4)(E)		6,55	6,63	6,77	6,59	6,71	6,85	6,81	6,67
Water flow user side	(2)	l/h	23786	26763	32255	35917	38875	44458	50140	52308
Water pressure drop user side	(2)(E)	kPa	48	30	44	55	29	38	46	60
Water flow DHW side	(3)	l/h	27027	30857	35499	41320	44858	50963	56026	59230
Water pressure drop DHW side	(3)(E)	kPa	62	57	53	72	39	59	57	75
Heating or DHW operation										
Heating capacity	(5)(E)	kW	156	178	206	240	261	295	326	343
Total power input	(5)(E)	kW	48,0	54,1	63,2	72,5	78,6	86,4	97,9	108
COP	(5)(E)		3,26	3,30	3,38	3,42	3,43	3,41	3,44	3,14
Water flow	(5)	l/h	27027	30857	35499	41320	44858	50963	56026	59230
Water pressure drop	(5)(E)	kPa	62	57	53	72	39	59	57	75
General data										
Maximum current absorption		A	105	126	148	167	190	215	229	242
Star up current		A	222	241	307	318	382	398	464	472
Star up current with soft starter		A	163	189	245	256	317	333	381	389
Compressors / circuits			4 / 2							
Expansion vessel volume		dm ³	24	24	24	24	24	24	24	24
Buffer tank volume		dm ³	600	600	600	600	600	765	765	765
Sound power level	(6)(E)	dB(A)	79	82	83	83	83	84	85	85
Transport weight unit with pump and tank		kg	1570	1710	1920	1920	1940	2290	2320	2350
Operating weight unit with pump and full tank		kg	2445	2585	2828	2828	2890	3405	3435	3465

- (1) Outdoor air temperature 35°C, water temperature 12°C / 7°C (EN14511:2013)
- (2) Cooling water temperature 7°C, water flow rate same as in cooling mode
- (3) Recovery water temperature 45°C, water flow rate same as in cooling mode
- (4) Cooling water temperature 7°C, recovery water temperature 45°C
- (5) Outdoor air temperature dry bulb 7°C / wet bulb 6°C, water temperature 40°C / 45°C (EN14511:2013)
- (6) Sound power level measured according to ISO 9614
- (E) EUROVENT certified data

Total heat recovery multi-purpose units LCP

LCP PS RATED TECHNICAL DATA OF MODELS FOR 4-PIPE SYSTEMS

LCP PS			41	51	61	71	81	94	104	124
Power supply		V-ph-Hz	400 - 3N - 50							
Cooling mode operation										
Cooling capacity	(1)(E)	kW	51,4	56,1	67,3	73,8	82,4	102	111	134
Total power input	(1)(E)	kW	16,2	18,3	20,8	23,4	27,0	32,7	37,1	44,1
EER	(1)(E)		3,17	3,07	3,24	3,15	3,06	3,10	3,00	3,04
Water flow	(1)	l/h	8874	9695	11616	12743	14227	17571	19157	23115
Water pressure drop	(1)(E)	kPa	29	34	34	41	32	37	43	45
Cooling and heating mode in total heat recovery										
Cooling capacity	(2)(E)	kW	46,2	50,6	60,1	66,1	78,8	92,5	101	119
Heating capacity	(3)(E)	kW	61,5	67,9	79,7	88,3	104	123	136	158
Total power input	(4)(E)	kW	16,1	18,1	20,6	23,3	26,0	32,1	36,2	41,4
COP HRE	(4)(E)		6,67	6,54	6,77	6,61	7,01	6,71	6,53	6,67
Water flow cooling side	(2)	l/h	8874	9695	11616	12743	14227	17571	19157	23115
Water pressure cooling heating side	(2)(E)	kPa	29	34	34	41	32	37	43	45
Water flow heating side	(3)	l/h	9744	10724	12702	13941	15534	19118	21122	24802
Water pressure drop heating side	(3)(E)	kPa	35	42	41	49	39	44	52	52
Heating mode operation										
Heating capacity	(5)(E)	kW	56,6	62,4	73,8	81,0	89,8	111	123	144
Total power input	(5)(E)	kW	16,8	18,7	21,9	24,4	26,5	33,4	37,2	45,6
COP	(5)(E)		3,37	3,32	3,37	3,32	3,38	3,33	3,30	3,16
Water flow	(5)	l/h	9744	10724	12702	13941	15534	19118	21122	24802
Water pressure drop	(5)(E)	kPa	35	42	41	49	39	44	52	52
General data										
Maximum current absorption		A	41	44	51	55	66	81	87	96
Star up current		A	159	162	185	183	191	194	198	220
Star up current with soft starter		A	88	101	111	124	139	122	137	146
Compressors / circuits			2 / 2	2 / 2	2 / 2	2 / 2	2 / 2	4 / 2	4 / 2	4 / 2
Expansion vessel volume		dm ³	8	8	8	8	8	8	8	24
Buffer tank volume		dm ³	200	200	220	220	220	340	340	600
Sound power level	(6)(E)	dB(A)	80	80	81	81	81	82	82	84
Transport weight unit with pump and tank		kg	882	892	1030	1040	1080	1500	1520	1805
Operating weight unit with pump and full tank		kg	1082	1092	1250	1260	1300	1840	1860	2405

- (1) Outdoor air temperature 35°C, water temperature 12°C / 7°C (EN14511:2013)
 (2) Cooling water temperature 7°C, water flow rate same as in cooling mode
 (3) Recovery water temperature 45°C, water flow rate same as in cooling mode
 (4) Cooling water temperature 7°C, recovery water temperature 45°C
 (5) Outdoor air temperature dry bulb 7°C / wet bulb 6°C, water temperature 40°C / 45°C (EN14511:2013)
 (6) Sound power level measured according to ISO 9614
 (E) EUROVENT certified data

LCP PS RATED TECHNICAL DATA OF MODELS FOR 4-PIPE SYSTEMS

LCP PS			144	164	194	214	244	274	294	324
Power supply		V-ph-Hz	400 - 3N - 50							
Cooling mode operation										
Cooling capacity	(1)(E)	kW	147	166	193	220	238	263	298	312
Total power input	(1)(E)	kW	49,2	55,6	66,9	75,7	84,2	92,4	103	117
EER	(1)(E)		2,99	2,98	2,87	2,90	2,81	2,85	2,88	2,68
Water flow	(1)	l/h	25411	28617	33237	37885	40949	45370	51321	53968
Water pressure drop	(1)(E)	kPa	54	49	46	59	58	39	48	63
Cooling and heating mode in total heat recovery										
Cooling capacity	(2)(E)	kW	130	150	185	208	230	253	287	304
Heating capacity	(3)(E)	kW	175	200	244	276	304	334	379	407
Total power input	(4)(E)	kW	46,8	52,6	61,5	72,2	78,4	85,2	96,2	108
COP HRE	(4)(E)		6,51	6,63	6,97	6,69	6,81	6,87	6,91	6,59
Water flow cooling side	(2)	l/h	25411	28617	33237	37885	40949	45370	51321	53968
Water pressure cooling heating side	(2)(E)	kPa	54	49	46	59	58	39	48	63
Water flow heating side	(3)	l/h	27348	31445	35879	42793	45279	51196	57519	59230
Water pressure drop heating side	(3)(E)	kPa	63	59	54	75	71	60	73	76
Heating mode operation										
Heating capacity	(5)(E)	kW	159	182	209	248	263	296	333	343
Total power input	(5)(E)	kW	50,6	56,3	65,3	74,6	80,6	88,6	99,3	110
COP	(5)(E)		3,13	3,23	3,19	3,31	3,26	3,34	3,35	3,11
Water flow	(5)	l/h	27348	31445	35879	42793	45279	51196	57519	59230
Water pressure drop	(5)(E)	kPa	63	59	54	75	71	60	73	76
General data										
Maximum current absorption		A	105	126	148	167	190	215	229	242
Star up current		A	222	241	307	318	382	398	464	472
Star up current with soft starter		A	163	189	245	256	317	333	381	389
Compressors / circuits			4 / 2							
Expansion vessel volume		dm ³	24	24	24	24	24	24	24	24
Buffer tank volume		dm ³	600	600	600	600	600	765	765	765
Sound power level	(6)(E)	dB(A)	84	85	85	86	86	86	87	87
Transport weight unit with pump and tank		kg	1825	1965	2198	2198	2260	2610	2640	2670
Operating weight unit with pump and full tank		kg	2425	2565	2798	2798	2860	3375	3405	3435

- (1) Outdoor air temperature 35°C, water temperature 12°C / 7°C (EN14511:2013)
 (2) Cooling water temperature 7°C, water flow rate same as in cooling mode
 (3) Recovery water temperature 45°C, water flow rate same as in cooling mode
 (4) Cooling water temperature 7°C, recovery water temperature 45°C
 (5) Outdoor air temperature dry bulb 7°C / wet bulb 6°C, water temperature 40°C / 45°C (EN14511:2013)
 (6) Sound power level measured according to ISO 9614
 (E) EUROVENT certified data

Total heat recovery multi-purpose units LCP

LCP PL RATED TECHNICAL DATA OF MODELS FOR 4-PIPE SYSTEMS

LCP PL			41	51	61	71	81	94	104	124
Power supply		V-ph-Hz	400 - 3N - 50							
Cooling mode operation										
Cooling capacity	(1)(E)	kW	48,0	52,1	64,7	70,4	78,3	97,6	105	127
Total power input	(1)(E)	kW	16,4	18,8	20,9	24,0	28,1	33,5	38,3	45,0
EER	(1)(E)		3,01	2,85	3,10	2,93	2,80	2,93	2,75	2,82
Water flow	(1)	l/h	8265	8961	11172	12153	13513	16855	18189	21904
Water pressure drop	(1)(E)	kPa	18	21	32	38	30	34	39	41
Cooling and heating mode in total heat recovery										
Cooling capacity	(2)(E)	kW	46,4	50,8	60,3	66,3	76,5	92,8	102	119
Heating capacity	(3)(E)	kW	61,6	68,0	79,9	88,5	101	123	136	158
Total power input	(4)(E)	kW	16,0	18,1	20,6	23,3	26,0	32,1	36,1	41,3
COP HRE	(4)(E)		6,74	6,55	6,79	6,63	6,83	6,73	6,57	6,71
Water flow cooling side	(2)	l/h	8265	8961	11172	12153	13513	16855	18189	21904
Water pressure cooling heating side	(2)(E)	kPa	18	21	32	38	30	34	39	41
Water flow heating side	(3)	l/h	9527	10446	12436	13780	15388	18720	20473	24392
Water pressure drop heating side	(3)(E)	kPa	23	28	40	48	38	42	49	50
Heating mode operation										
Heating capacity	(5)(E)	kW	55,4	60,7	72,0	79,8	89,0	109	119	141
Total power input	(5)(E)	kW	15,8	17,8	20,2	22,7	25,6	31,5	35,2	42,9
COP	(5)(E)		3,59	3,53	3,56	3,52	3,48	3,54	3,48	3,29
Water flow	(5)	l/h	9527	10446	12436	13780	15388	18720	20473	24392
Water pressure drop	(5)(E)	kPa	23	28	40	48	38	42	49	50
General data										
Maximum current absorption		A	41	44	51	55	66	81	87	96
Star up current		A	159	162	185	183	191	194	198	220
Star up current with soft starter		A	88	101	111	124	139	122	137	146
Compressors / circuits			2 / 2	2 / 2	2 / 2	2 / 2	2 / 2	4 / 2	4 / 2	4 / 2
Expansion vessel volume		dm ³	8	8	8	8	8	8	8	24
Buffer tank volume		dm ³	200	200	220	220	220	340	340	600
Sound power level	(6)(E)	dB(A)	73	74	76	76	76	77	77	79
Transport weight unit with pump and tank		kg	892	902	1040	1050	1090	1520	1540	1825
Operating weight unit with pump and full tank		kg	1092	1102	1260	1270	1310	1860	1880	2425

- (1) Outdoor air temperature 35°C, water temperature 12°C / 7°C (EN14511:2013)
 (2) Cooling water temperature 7°C, water flow rate same as in cooling mode
 (3) Recovery water temperature 45°C, water flow rate same as in cooling mode
 (4) Cooling water temperature 7°C, recovery water temperature 45°C
 (5) Outdoor air temperature dry bulb 7°C / wet bulb 6°C, water temperature 40°C / 45°C (EN14511:2013)
 (6) Sound power level measured according to ISO 9614
 (E) EUROVENT certified data

LCP PL RATED TECHNICAL DATA OF MODELS FOR 4-PIPE SYSTEMS

LCP PL			144	164	194	214	244	274	294	324
Power supply		V-ph-Hz	400 - 3N - 50							
Cooling mode operation										
Cooling capacity	(1)(E)	kW	138	156	187	209	226	258	291	303
Total power input	(1)(E)	kW	51,2	57,1	67,4	77,0	86,7	92,7	105	119
EER	(1)(E)		2,69	2,59	2,78	2,82	2,73	2,79	2,79	2,55
Water flow	(1)	l/h	23786	26763	32255	35917	38875	44458	50140	52308
Water pressure drop	(1)(E)	kPa	48	30	44	55	29	38	46	60
Cooling and heating mode in total heat recovery										
Cooling capacity	(2)(E)	kW	131	150	180	204	228	252	283	308
Heating capacity	(3)(E)	kW	175	200	238	272	302	334	375	411
Total power input	(4)(E)	kW	46,7	52,6	61,6	72,1	78,8	85,5	96,5	108
COP HRE	(4)(E)		6,55	6,63	6,77	6,59	6,71	6,85	6,81	6,67
Water flow cooling side	(2)	l/h	23786	26763	32255	35917	38875	44458	50140	52308
Water pressure cooling heating side	(2)(E)	kPa	48	30	44	55	29	38	46	60
Water flow heating side	(3)	l/h	27027	30857	35499	41320	44858	50963	56026	59230
Water pressure drop heating side	(3)(E)	kPa	62	57	53	72	39	59	57	75
Heating mode operation										
Heating capacity	(5)(E)	kW	156	178	206	240	261	295	326	343
Total power input	(5)(E)	kW	48,0	54,1	63,2	72,5	78,6	86,4	97,9	108
COP	(5)(E)		3,26	3,30	3,38	3,42	3,43	3,41	3,44	3,14
Water flow	(5)	l/h	27027	30857	35499	41320	44858	50963	56026	59230
Water pressure drop	(5)(E)	kPa	62	57	53	72	39	59	57	75
General data										
Maximum current absorption		A	105	126	148	167	190	215	229	242
Star up current		A	222	241	307	318	382	398	464	472
Star up current with soft starter		A	163	189	245	256	317	333	381	389
Compressors / circuits			4 / 2							
Expansion vessel volume		dm ³	24	24	24	24	24	24	24	24
Buffer tank volume		dm ³	600	600	600	600	600	765	765	765
Sound power level	(6)(E)	dB(A)	79	80	81	82	82	83	83	83
Transport weight unit with pump and tank		kg	1845	1985	2228	2228	2290	2640	2670	2700
Operating weight unit with pump and full tank		kg	2445	2585	2828	2828	2890	3405	3435	3465

- (1) Outdoor air temperature 35°C, water temperature 12°C / 7°C (EN14511:2013)
 (2) Cooling water temperature 7°C, water flow rate same as in cooling mode
 (3) Recovery water temperature 45°C, water flow rate same as in cooling mode
 (4) Cooling water temperature 7°C, recovery water temperature 45°C
 (5) Outdoor air temperature dry bulb 7°C / wet bulb 6°C, water temperature 40°C / 45°C (EN14511:2013)
 (6) Sound power level measured according to ISO 9614
 (E) EUROVENT certified data

Total heat recovery multi-purpose units LCP

DIMENSIONAL DRAWINGS

LCP 41 - 51

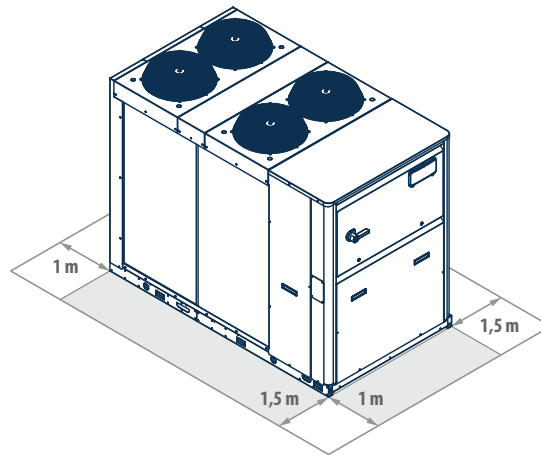
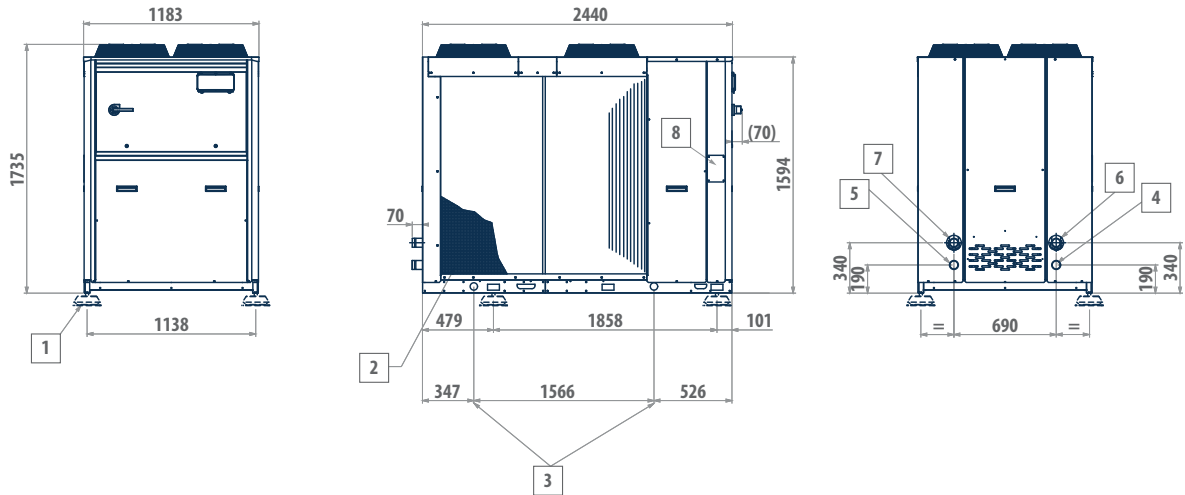

LEGEND

1	Vibration dampers
2	Protection grill (optional)
3	Lifting points
4	Hot water inlet (Victaulic 2")
5	Cold water inlet (Victaulic 2")
6	Hot water outlet (Victaulic 2")
7	Cold water outlet (Victaulic 2")
8	Power supply input

MODEL VERSION

LCP 41	M-P	S-L
LCP 51	M-P	S-L

DIMENSIONAL DRAWINGS

LCP 61 - 81

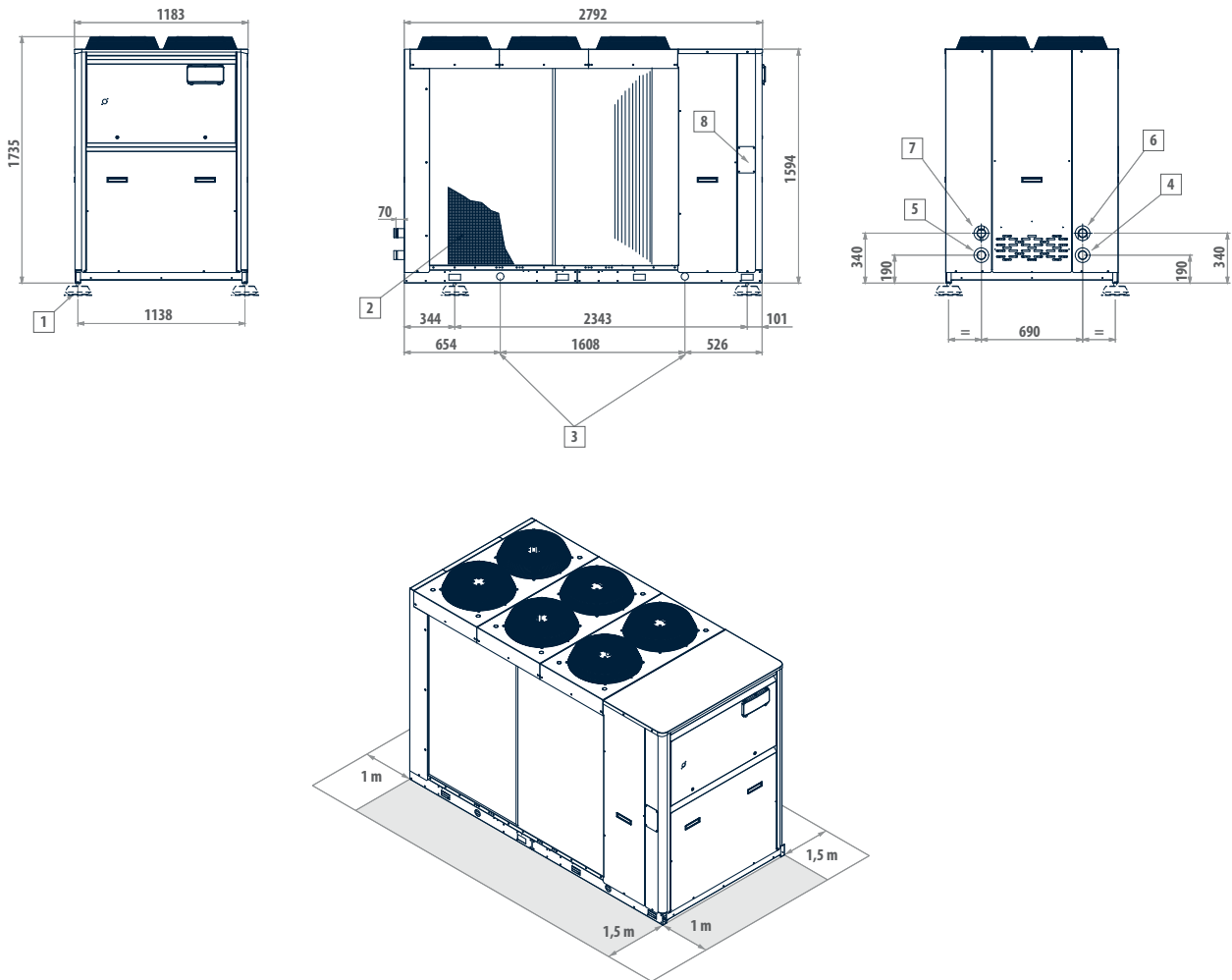

LEGEND

1	Vibration dampers
2	Protection grill (optional)
3	Lifting points
4	Hot water inlet (Victaulic 2")
5	Cold water inlet (Victaulic 2")
6	Hot water outlet (Victaulic 2")
7	Cold water outlet (Victaulic 2")
8	Power supply input

MODEL	VERSION	
LCP 61	M-P	S-L
LCP 71	M-P	S-L
LCP 81	M-P	S-L

Total heat recovery multi-purpose units LCP

DIMENSIONAL DRAWINGS

LCP 94 - 104

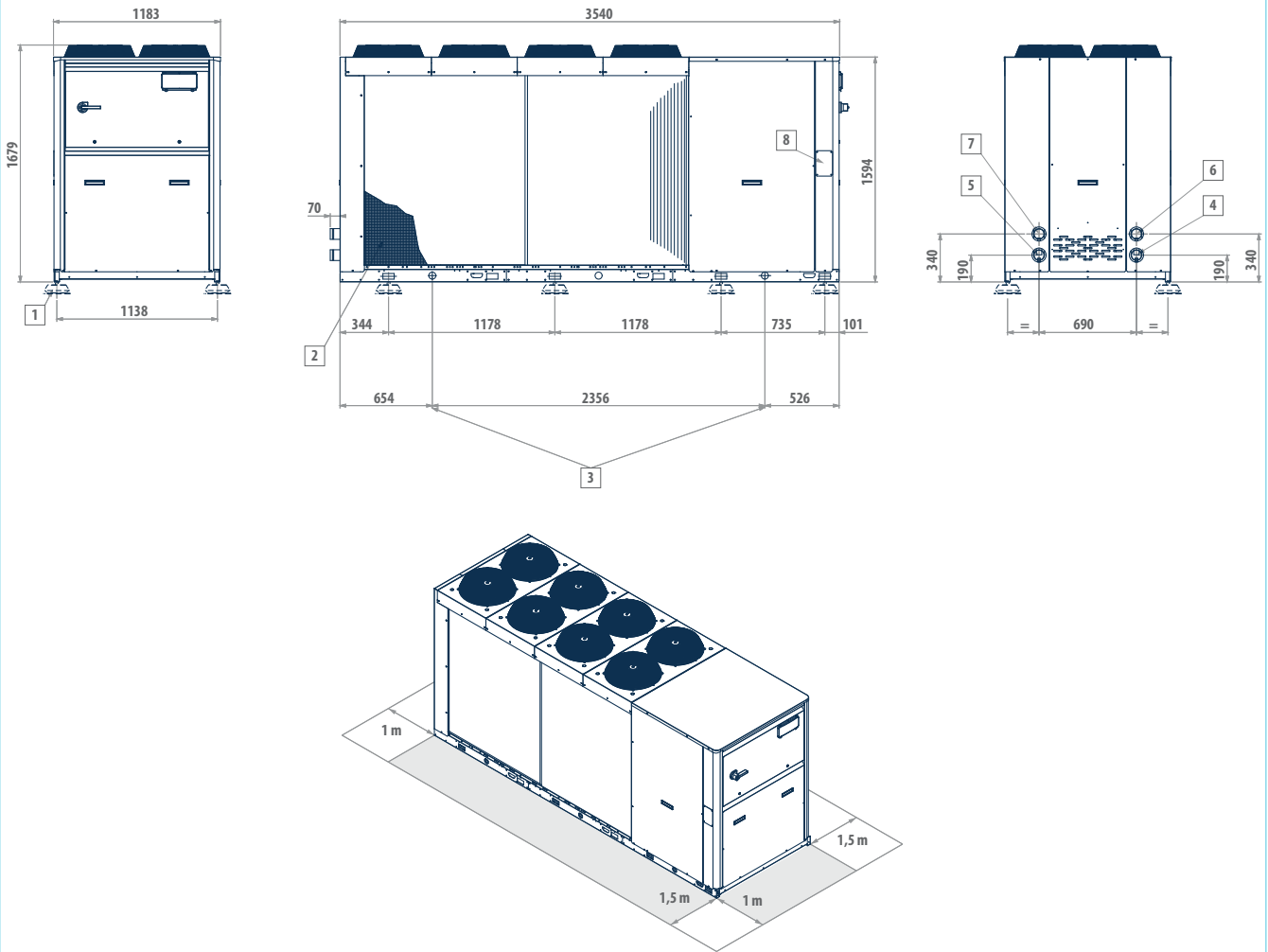

LEGEND

1	Vibration dampers
2	Protection grill (optional)
3	Lifting points
4	Hot water inlet (Victaulic 2 1/2")
5	Cold water inlet (Victaulic 2 1/2")
6	Hot water outlet (Victaulic 2 1/2")
7	Cold water outlet (Victaulic 2 1/2")
8	Power supply input

MODEL VERSION

LCP 94	M-P	S-L
LCP 104	M-P	S-L

DIMENSIONAL DRAWINGS

LCP 124 - 164

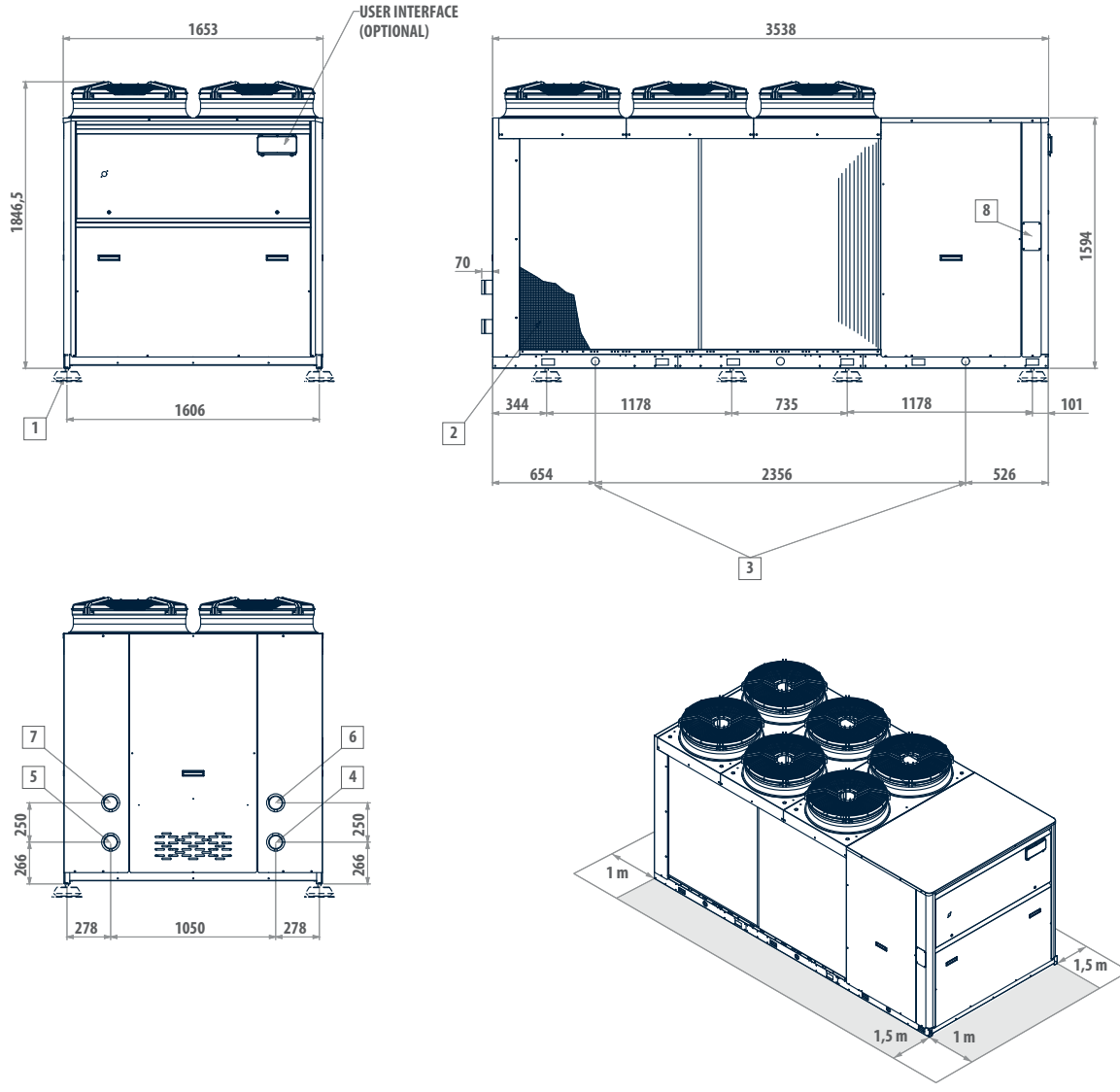

LEGEND

1	Vibration dampers
2	Protection grill (optional)
3	Lifting points
4	Ingresso acqua calda (Victaulic 3")
5	Cold water inlet (Victaulic 3")
6	Hot water outlet (Victaulic 3")
7	Cold water outlet (Victaulic 3")
8	Power supply input

MODEL	VERSION	
LCP 124	M-P	S-L
LCP 144	M-P	S-L
LCP 164	M-P	S-L

Total heat recovery multi-purpose units LCP

DIMENSIONAL DRAWINGS

LCP 194 - 244

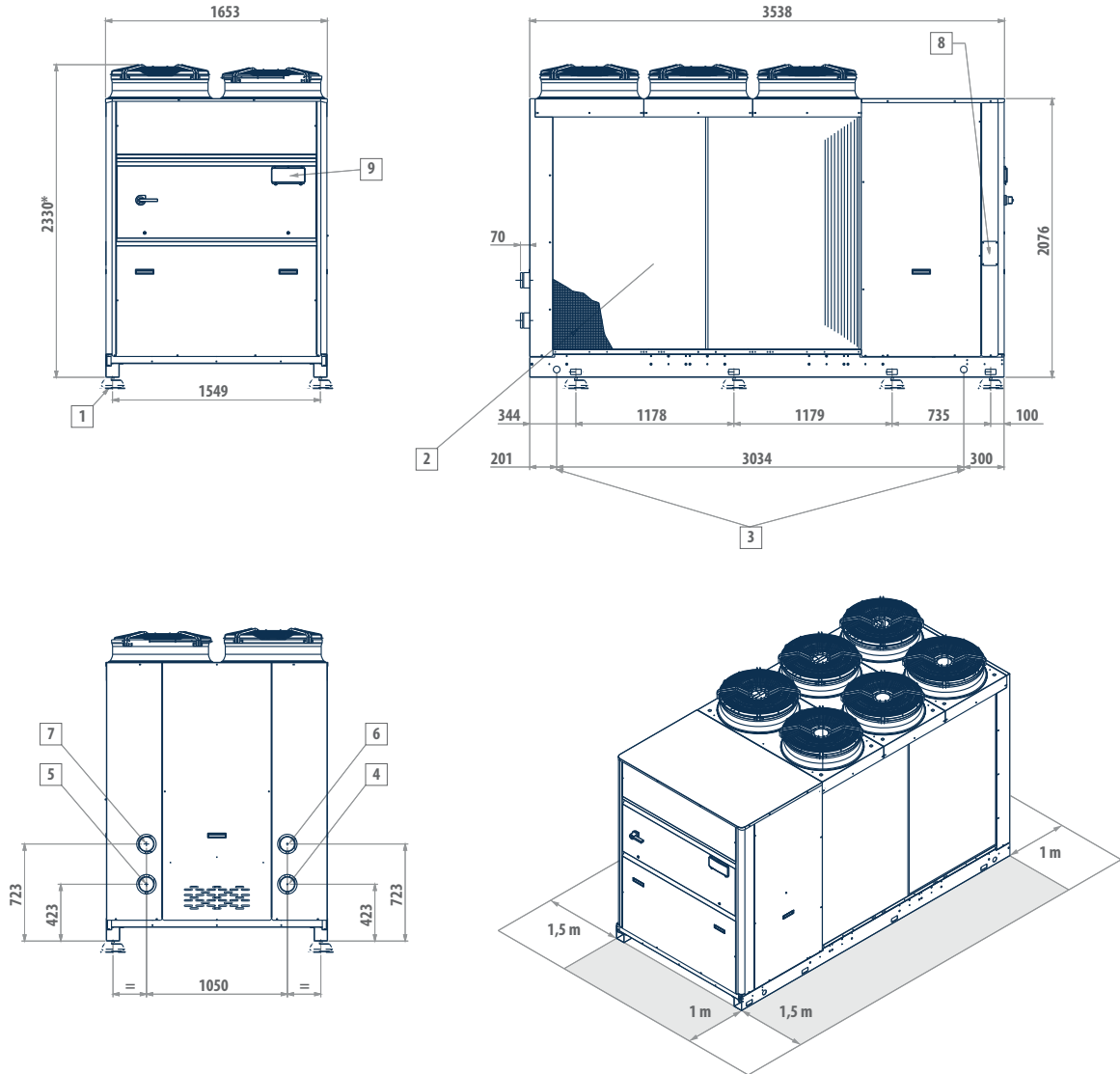

LEGEND

- | | |
|---|----------------------------------|
| 1 | Vibration dampers |
| 2 | Protection grill (optional) |
| 3 | Lifting points |
| 4 | Hot water inlet (Victaulic 4") |
| 5 | Cold water inlet (Victaulic 4") |
| 6 | Hot water outlet (Victaulic 4") |
| 7 | Cold water outlet (Victaulic 4") |
| 8 | Power supply input |
| 9 | User interface (optional) |

WITH EC=2367 FANS

MODEL	VERSION	
LCP 194	M-P	S-L
LCP 214	M-P	S-L
LCP 244	M-P	S-L

DIMENSIONAL DRAWINGS

LCP 274 - 324

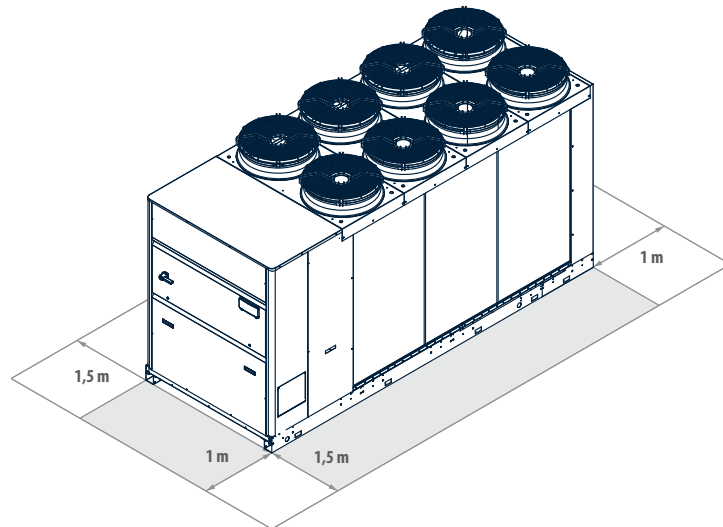
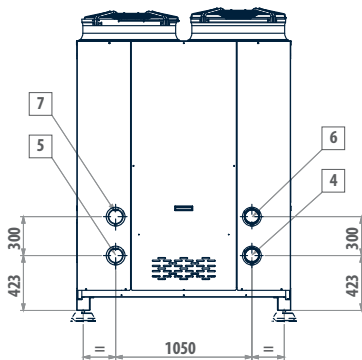
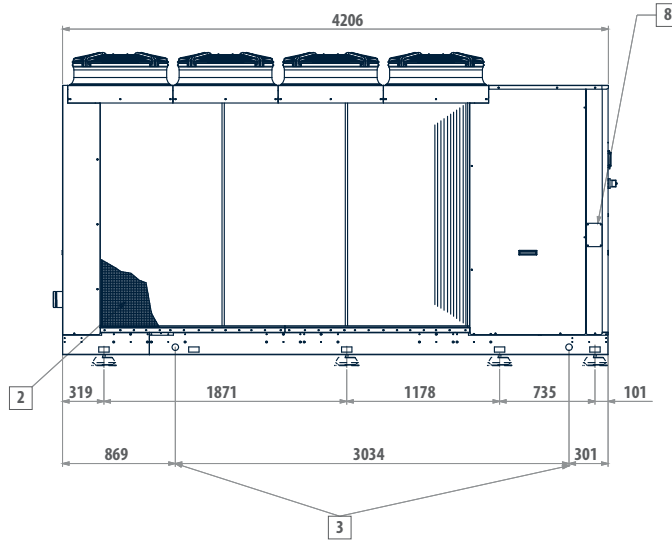
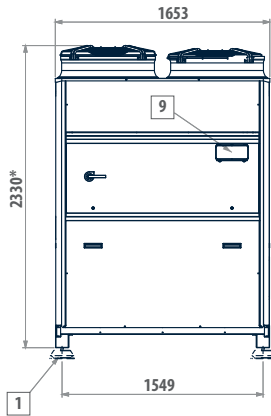

LEGEND

1	Vibration dampers
2	Protection grill (optional)
3	Lifting points
4	Hot water inlet (Victaulic 4")
5	Cold water inlet (Victaulic 4")
6	Hot water outlet (Victaulic 4")
7	Cold water outlet (Victaulic 4")
8	Power supply input
9	User interface (optional)

WITH EC=2367 FANS

MODEL	VERSION	
LCP 274	M-P	S-L
LCP 294	M-P	S-L
LCP 324	M-P	S-L

Total heat recovery multi-purpose units LEP

Indoor packaged water-water unit

LEP 50 - 470 kW



Scroll
compressor



Refrigerant
R-410A



Heating/
Cooling



Total heat
recovery
multi-pur-
pose unit



Multi-purpose
2 pipes
system



Multi-purpose
4 pipes
system

Maximum efficiency with total recovery and dissipation in water.

LEP units are actually multi-purpose, they totally recover the condensation heat and they are characterized by the simultaneous production of cold and hot water. Available for two-pipe systems with the request of DHW production or in four-pipe systems, they are conceived for average-high power applications (multi residential or commercial unit) and they guarantee a high thermodynamic efficiency and a wide configurability both in terms of accessories and in terms of refrigeration cycle.

LEP series is characterized by a reduced size, high thermodynamic cycle COP, no external noise, reduced cooling load and it is composed of 24 models with refrigeration capacity ranging from 50 to 470 kW both for the standard version and the silenced one.

Multi-purpose LEP machines have six water connections linked to three different hydraulic circuits of which a dissipation one (hot or cold) opposed to the consumption. The users differ as for two-pipe system in which there is a hot/cold circuit and just one hot circuit for the production of DHW while in four-pipe systems there is one hot circuit and a cold one.

There is the option to obtain an external sound-proof hydraulic module with circulation pumps for dissipation circuits, users and domestic hot water.

PLUS

- » Maximum energy efficiency
- » Total condensation heat recovery
- » Electronic expansion valve
- » Up to 4 compressors
- » Remote connectivity with the most common protocols
- » Compact dimensions
- » Low-noise level thanks to the paneled structure

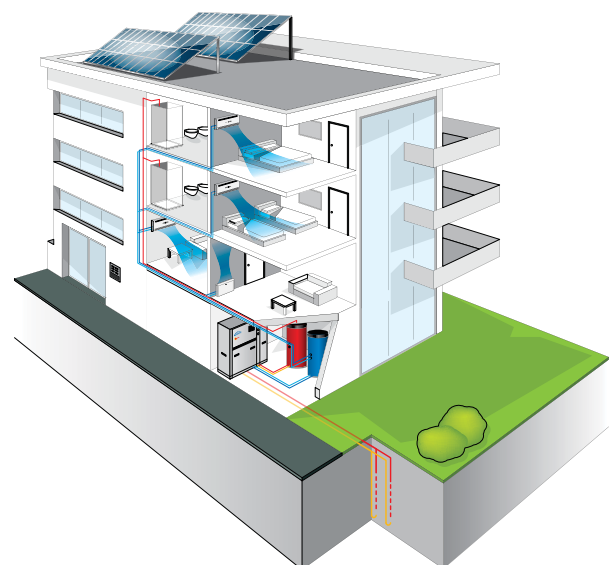

LEP is suitable to the air-conditioning of 2-pipe systems with production of DHW or in 4-pipe systems. In both, the total recovery of the heat ensures remarkable energy savings.

MAIN COMPONENTS

LEP-M: chiller mode

In the "Chiller" mode the unit cools water to air condition the interior on the user side, dissipating the condensation heat by means of water that is cooled in the dissipation exchanger.

LEP-M: chiller + DHW

In the "Chiller + DHW" mode the unit can produce chilled water with the simultaneous production of high-temperature hot water for sanitary use, thanks to total heat recovery.

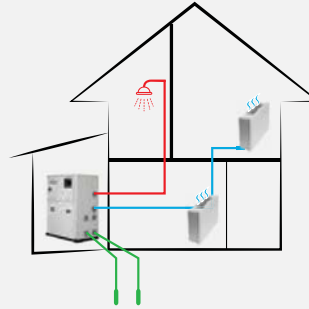

LEP-M: DHW mode

In the "high-temperature sanitary hot water (DHW)" mode the unit heats water in the condenser, dedicated to DHW as needed, dissipating the evaporative cooling capacity by means of water that is heated in the exchanger on the dissipation side.

LEP-M: heating pump mode

In the "heat pump" mode the unit heats the water in the condenser to warm the interior on the user side, dissipating the evaporative cooling capacity by means of water that is heated in the dissipation exchanger.

LEP-P: 4-pipes systems

The four-pipe system has a distribution system that offers both hot water (with respective return lines) and chilled water (with respective return lines). The LEP-P unit has a circuit used for the production of hot water and another one used for the production of cold water.

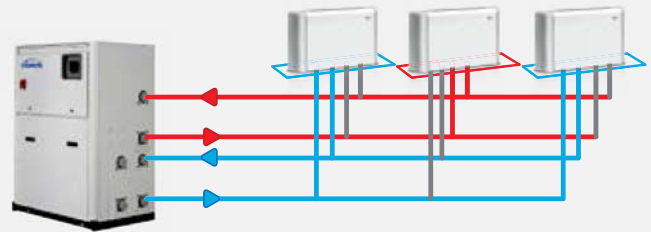

CONFIGURATOR

The models are completely configurable by selecting the version and the options. To the right is shown an example of configuration.

Version	Fields	1	2	3	4	5	6	7	8	9
LEP214ML		2	B	P	0	2	G	0	0	B

To verify the compatibility of the options, use the selection software or the price list.

AVAILABLE VERSIONS

2-pipe system versions

LEP-MS	Standard execution
LEP-ML	Low noise execution

4-pipe system versions

LEP-PS	Standard execution
LEP-PL	Low noise execution

CONFIGURATION OPTIONS

- 1 Power supply**
 - 0 400 V - 3 N - 50 Hz
 - 2 400 V - 3 N - 50 Hz + magnetic breakers
- 2 Onboard controller and expansion valve**
 - B Advanced + electronic expansion valve
- 3 Source water flow modulation**
 - 0 Absent
 - P 0-10V signal for condensation control
- 4 User water flow modulation**
 - 0 Absent
 - D 0-10V signal for water flow adjustment with $\Delta T = \text{const}$ (advanced controller required)
 - T 0-10V signal for water flow adjustment with $T = \text{const}$ (advanced controller required)
- 5 Remote communication**
 - 0 Absent
 - 1 RS485 serial board (Carel / Modbus protocol)
 - 2 LON FT10 serial board (advanced controller required)
 - 3 GSM modem board (advanced controller required)
 - 4 BACNET IP / PCOWEB serial board + supervision software Gweb (advanced controller required)
 - 5 BACNET IP / PCOWEB serial board + clock board + supervision software Gweb (advanced controller required)
- 6 Anti vibration shock mounts**
 - 0 Absent
 - G Rubber anti vibration shock mounts
 - M Spring anti vibration shock mounts

- 7 Packing**
 - 0 Standard
 - 1 Wooden cage
 - 2 Wooden crate
- 8 Remote control**
 - 0 Absent
 - 3 Remote simplified user panel for advanced controller
- 9 Insulated hydraulic module**
 - 0 Absent
 - A Water pumps LP user + LP inverter source + LP recovery
 - B Water pumps LP user + LP source + LP recovery
 - C Water pumps LP user + HP source + LP recovery
 - D Water pumps LP user + HP inverter source + LP recovery
 - E Water pumps HP user + LP source + LP recovery
 - F Water pumps HP user + LP inverter source + LP recovery
 - G Water pumps LP user + LP source + LP recovery
 - H Water pumps HP user + HP inverter source + LP recovery
 - I Water pumps LP user + LP inverter source + HP recovery
 - J Water pumps LP user + LP source + HP recovery
 - K Water pumps LP user + HP source + HP recovery
 - L Water pumps LP user + HP inverter source + HP recovery
 - M Water pumps HP user + HP source + HP recovery
 - N Water pumps HP user + LP inverter source + HP recovery
 - P Water pumps HP user + HP source + HP recovery
 - Q Water pumps HP user + HP inverter source + HP recovery

ACCESSORIES

A	Power factor capacitors	F	Refrigerant pressure gauges
B	Soft starter	G	Three couples of Victaulic joints
C	Service kit (advanced controller required)	H	Filter isolation valves kit (solenoid valve and isolation valve)
D	ON/OFF status of the compressors	I	4-way valve for water flow inversion on user side in the hydraulic module
E	Set point compensation outdoor temperature probe		

Total heat recovery multi-purpose units LEP

RATED TECHNICAL DATA FOR 2-PIPES + DHW SYSTEMS

LEP M			042	052	062	072	082	092
Power supply		V-ph-Hz	400 - 3N - 50					
Cooling mode operation								
Cooling capacity	(1)	kW	50,8	59,7	69,3	78,0	90,0	100
Total power input	(1)	kW	9,00	11,7	12,7	14,6	15,9	18,1
EER	(1)		5,64	5,10	5,46	5,34	5,66	5,55
SEER	(2)		5,61	5,52	5,87	5,81	6,17	6,12
Water flow user side	(1)	l/h	8776	10330	11974	13485	15537	17337
Water pressure drop user side	(1)	kPa	37	49	50	48	38	48
Water flow source side	(1)	l/h	3414	4073	4677	5286	6044	6760
Water pressure drop source side	(1)	kPa	7	9	7	9	7	8
Cooling mode operation and DHW in total recovery								
Cooling capacity	(3)	kW	42,5	50,6	57,8	65,8	75,5	83,9
Heating capacity	(3)	kW	54,5	65,7	74,5	85,1	96,6	108
Total power input	(3)	kW	12,6	15,9	17,6	20,2	22,1	25,4
COP HRE	(3)		7,70	7,31	7,52	7,47	7,79	7,56
Water flow user side	(3)	l/h	7333	8735	9982	11357	13019	14474
Water pressure drop user side	(3)	kPa	27	36	36	35	27	34
Water flow DHW side	(3)	l/h	9418	11336	12861	14684	16694	18668
Water pressure drop DHW side	(3)	kPa	42	58	57	56	43	54
Heating or DHW operation								
Heating capacity	(4)	kW	59,4	71,5	81,1	92,4	105	118
Total power input	(4)	kW	12,8	16,2	17,8	20,5	22,4	25,6
COP	(4)		4,64	4,41	4,56	4,51	4,69	4,60
SCOP	(2)		4,16	4,30	4,38	4,31	4,36	4,21
Heating energy efficiency class	(5)		A+++					
Water flow user side	(4)	l/h	10253	12322	13994	15941	18139	20315
Water pressure drop user side	(4)	kPa	48	67	67	65	50	63
Water flow source side	(4)	l/h	8164	9694	11093	12594	14447	16114
Water pressure drop source side	(4)	kPa	31	43	33	42	33	40
General data								
Maximum current absorption		A	30	37	40	46	50	61
Star up current		A	111	156	158	181	178	186
Star up current with soft starter		A	73	84	97	106	119	134
Compressors / circuits			2 / 1					
Sound power level	(6)	dB(A)	72	72	73	73	74	76
Sound power level, low-noise version	(6)	dB(A)	68	68	69	69	70	72
Transport / operating weight		kg	410	420	450	460	490	510

(1) Water temperature - user side 12°C / 7°C, water temperature - dissipation side 15°C / 30°C (EN14511:2013)

(2) η efficiency values for heating and cooling are respectively calculated by the following formulas: $[\eta = SCOP / 2,5 - F(1) - F(2)]$ e $[\eta = SEER / 2,5 - F(1) - F(2)]$. For further information, please refer to the technical document "ErP 2009/125/EC DIRECTIVE" in the catalogue introducing pages, or to the EN14825:2017 regulation.

(3) Cooling water temperature 12°C / 7°C, recovery water temperature 40°C / 45°C (EN14511:2013)

(4) Water temperature - user side 40°C / 45°C, water temperature - source side 15°C / 10°C (EN14511:2013)

(5) Seasonal energy efficiency class for MEDIUM TEMPERATURE room heating under AVERAGE climatic conditions [EUROPEAN REGULATION No 811/2013]

(6) Sound power level measured according to ISO 9614

RATED TECHNICAL DATA FOR 2-PIPES + DHW SYSTEMS

LEP M			112	132	142	144	162	164
Power supply		V-ph-Hz	400 - 3N - 50					
Cooling mode operation								
Cooling capacity	(1)	kW	122	138	159	158	177	178
Total power input	(1)	kW	20,8	24,1	27,9	28,8	32,0	31,8
EER	(1)		5,84	5,75	5,69	5,49	5,53	5,60
SEER	(2)		6,40	6,38	6,31	6,07	6,17	6,19
Water flow user side	(1)	l/h	20958	23908	27403	27299	30542	30731
Water pressure drop user side	(1)	kPa	41	50	48	47	52	52
Water flow source side	(1)	l/h	8124	9280	10658	10673	11925	11979
Water pressure drop source side	(1)	kPa	7	9	8	8	9	9
Cooling mode operation and DHW in total recovery								
Cooling capacity	(3)	kW	102	116	133	134	149	149
Heating capacity	(3)	kW	130	148	170	172	191	192
Total power input	(3)	kW	29,5	34,4	39,2	39,9	44,3	44,4
COP HRE	(3)		7,84	7,67	7,74	7,65	7,67	7,68
Water flow user side	(3)	l/h	17509	19938	22954	23050	25651	25738
Water pressure drop user side	(3)	kPa	30	36	35	35	38	38
Water flow DHW side	(3)	l/h	22418	25636	29462	29671	33006	33122
Water pressure drop DHW side	(3)	kPa	47	57	54	55	60	60
Heating or DHW operation								
Heating capacity	(4)	kW	141	161	185	186	208	208
Total power input	(4)	kW	29,8	34,7	39,5	40,3	44,7	45,0
COP	(4)		4,73	4,65	4,69	4,63	4,64	4,63
SCOP	(2)		4,29	4,24	4,29	4,34	4,28	4,28
Heating energy efficiency class	(5)		A+++					
Water flow user side	(4)	l/h	24385	27855	32009	32243	35854	35982
Water pressure drop user side	(4)	kPa	54	66	63	63	70	69
Water flow source side	(4)	l/h	19466	22145	25486	25584	28482	28558
Water pressure drop source side	(4)	kPa	34	43	40	40	44	45
General data								
Maximum current absorption		A	70	79	91	95	102	103
Star up current		A	240	248	291	219	302	220
Star up current with soft starter		A	178	186	226	170	237	171
Compressors / circuits			2 / 1	2 / 1	2 / 1	4 / 2	2 / 1	4 / 2
Sound power level	(6)	dB(A)	76	77	77	80	77	80
Sound power level, low-noise version	(6)	dB(A)	72	73	73	76	73	76
Transport / operating weight		kg	690	700	770	1010	830	1050

(1) Water temperature - user side 12°C / 7°C, water temperature - dissipation side 15°C / 30°C (EN14511:2013)

(2) η efficiency values for heating and cooling are respectively calculated by the following formulas: $[\eta = SCOP / 2,5 - F(1) - F(2)]$ e $[\eta = SEER / 2,5 - F(1) - F(2)]$. For further information, please refer to the technical document "ErP 2009/125/EC DIRECTIVE" in the catalogue introducing pages, or to the EN14825:2017 regulation.

(3) Cooling water temperature 12°C / 7°C, recovery water temperature 40°C / 45°C (EN14511:2013)

(4) Water temperature - user side 40°C / 45°C, water temperature - source side 15°C / 10°C (EN14511:2013)

(5) Seasonal energy efficiency class for MEDIUM TEMPERATURE room heating under AVERAGE climatic conditions [EUROPEAN REGULATION No 811/2013]

(6) Sound power level measured according to ISO 9614

Total heat recovery multi-purpose units LEP

RATED TECHNICAL DATA FOR 2-PIPES + DHW SYSTEMS

LEP M			182	184	204	214	243	244
Power supply		V-ph-Hz	400 - 3N - 50					
Cooling mode operation								
Cooling capacity	(1)	kW	211	206	223	243	272	284
Total power input	(1)	kW	37,0	35,4	38,5	41,5	47,0	46,7
EER	(1)		5,71	5,81	5,79	5,87	5,78	6,08
SEER	(2)		6,37	6,47	6,43	6,54	6,53	6,87
Water flow user side	(1)	l/h	36435	35502	38427	41971	46839	48896
Water pressure drop user side	(1)	kPa	46	45	51	49	51	33
Water flow source side	(1)	l/h	14171	13777	14922	16268	18194	18881
Water pressure drop source side	(1)	kPa	8	8	9	9	9	5
Cooling mode operation and DHW in total recovery								
Cooling capacity	(3)	kW	177	172	186	204	230	238
Heating capacity	(3)	kW	226	219	238	260	292	302
Total power input	(3)	kW	51,3	49,7	54,5	58,8	65,3	66,7
COP HRE	(3)		7,85	7,87	7,79	7,87	7,98	8,09
Water flow user side	(3)	l/h	30513	29627	32115	35085	39581	40986
Water pressure drop user side	(3)	kPa	34	32	37	35	38	24
Water flow DHW side	(3)	l/h	39076	37935	41197	44897	50482	52229
Water pressure drop DHW side	(3)	kPa	53	51	58	55	58	38
Heating or DHW operation								
Heating capacity	(4)	kW	246	239	259	283	317	327
Total power input	(4)	kW	51,9	50,1	55,1	59,3	65,9	67,3
COP	(4)		4,73	4,77	4,71	4,77	4,81	4,86
SCOP	(2)		4,34	4,37	4,31	4,34	4,43	4,43
Heating energy efficiency class	(5)		A+++					
Water flow user side	(4)	l/h	42453	41353	44837	48891	54768	56606
Water pressure drop user side	(4)	kPa	61	59	68	64	67	44
Water flow source side	(4)	l/h	33846	33038	35730	39067	43844	45326
Water pressure drop source side	(4)	kPa	39	38	44	42	45	26
General data								
Maximum current absorption		A	116	120	130	140	153	161
Star up current		A	368	273	291	297	336	310
Star up current with soft starter		A	285	214	226	233	271	245
Compressors / circuits			2 / 1	4 / 2	4 / 2	4 / 2	3 / 1	4 / 2
Sound power level	(6)	dB(A)	78	81	81	81	81	82
Sound power level, low-noise version	(6)	dB(A)	74	77	77	77	77	78
Transport / operating weight		kg	890	1130	1280	1350	1850	1840

(1) Water temperature - user side 12°C / 7°C, water temperature - dissipation side 15°C / 30°C (EN14511:2013)

(2) η efficiency values for heating and cooling are respectively calculated by the following formulas: $[\eta = SCOP / 2,5 - F(1) - F(2)]$ e $[\eta = SEER / 2,5 - F(1) - F(2)]$. For further information, please refer to the technical document "ErP 2009/125/EC DIRECTIVE" in the catalogue introducing pages, or to the EN14825:2017 regulation.

(3) Cooling water temperature 12°C / 7°C, recovery water temperature 40°C / 45°C (EN14511:2013)

(4) Water temperature - user side 40°C / 45°C, water temperature - source side 15°C / 10°C (EN14511:2013)

(5) Seasonal energy efficiency class for MEDIUM TEMPERATURE room heating under AVERAGE climatic conditions [EUROPEAN REGULATION No 811/2013]

(6) Sound power level measured according to ISO 9614

RATED TECHNICAL DATA FOR 2-PIPES + DHW SYSTEMS

LEP M			283	284	314	344	374	424
Power supply		V-ph-Hz	400 - 3N - 50					
Cooling mode operation								
Cooling capacity	(1)	kW	313	317	348	381	414	475
Total power input	(1)	kW	55,0	54,9	63,3	68,4	73,5	80,5
EER	(1)		5,69	5,78	5,50	5,57	5,63	5,90
SEER	(2)		6,60	6,67	6,31	6,40	6,47	6,77
Water flow user side	(1)	l/h	53930	54637	60047	65714	71374	81840
Water pressure drop user side	(1)	kPa	39	40	48	47	46	48
Water flow source side	(1)	l/h	21010	21243	23495	25670	27842	31712
Water pressure drop source side	(1)	kPa	7	7	8	8	8	8
Cooling mode operation and DHW in total recovery								
Cooling capacity	(3)	kW	263	266	294	321	348	396
Heating capacity	(3)	kW	336	340	378	411	446	508
Total power input	(3)	kW	76,6	77,3	88,1	95,1	102	118
COP HRE	(3)		7,83	7,85	7,62	7,70	7,76	7,68
Water flow user side	(3)	l/h	45343	45905	50624	55270	60024	68143
Water pressure drop user side	(3)	kPa	29	29	35	34	34	34
Water flow DHW side	(3)	l/h	58202	58887	65356	71210	77195	87885
Water pressure drop DHW side	(3)	kPa	45	46	56	54	53	54
Heating or DHW operation								
Heating capacity	(4)	kW	364	369	410	447	484	550
Total power input	(4)	kW	77,4	78,0	88,8	96,2	104	119
COP	(4)		4,71	4,73	4,61	4,64	4,66	4,62
SCOP	(2)		4,41	4,37	4,29	4,34	4,34	4,20
Heating energy efficiency class	(5)		A+++					
Water flow user side	(4)	l/h	63082	63868	70853	77301	83657	95146
Water pressure drop user side	(4)	kPa	52	53	65	63	61	63
Water flow source side	(4)	l/h	50157	50846	56099	61287	66384	75351
Water pressure drop source side	(4)	kPa	32	34	41	39	39	40
General data								
Maximum current absorption		A	174	184	207	221	234	281
Star up current		A	401	362	384	447	447	490
Star up current with soft starter		A	318	286	306	351	359	420
Compressors / circuits			3 / 1	4 / 2	4 / 2	4 / 2	4 / 2	4 / 2
Sound power level	(6)	dB(A)	81	82	82	83	83	83
Sound power level, low-noise version	(6)	dB(A)	77	78	78	79	79	79
Transport / operating weight		kg	1880	1940	2040	2110	2180	2380

(1) Water temperature - user side 12°C / 7°C, water temperature - dissipation side 15°C / 30°C (EN14511:2013)

(2) η efficiency values for heating and cooling are respectively calculated by the following formulas: $\eta = SCOP / 2,5 - F(1) - F(2)$ e $\eta = SEER / 2,5 - F(1) - F(2)$. For further information, please refer to the technical document "ErP 2009/125/EC DIRECTIVE" in the catalogue introducing pages, or to the EN14825:2017 regulation.

(3) Cooling water temperature 12°C / 7°C, recovery water temperature 40°C / 45°C (EN14511:2013)

(4) Water temperature - user side 40°C / 45°C, water temperature - source side 15°C / 10°C (EN14511:2013)

(5) Seasonal energy efficiency class for MEDIUM TEMPERATURE room heating under AVERAGE climatic conditions [EUROPEAN REGULATION No 811/2013]

(6) Sound power level measured according to ISO 9614

Total heat recovery multi-purpose units LEP

RATED TECHNICAL DATA FOR 4-PIPES SYSTEMS

LEP P			042	052	062	072	082	092
Power supply		V-ph-Hz	400 - 3N - 50					
Cooling mode operation								
Cooling capacity	(1)	kW	50,8	59,7	69,3	78,0	90,0	100
Total power input	(1)	kW	9,00	11,7	12,7	14,6	15,9	18,1
EER	(1)		5,64	5,10	5,46	5,34	5,66	5,55
SEER	(2)		5,61	5,52	5,87	5,81	6,17	6,12
Cooling efficiency class	(3)		AA					
Water flow user side	(1)	l/h	8776	10330	11974	13485	15537	17337
Water pressure drop user side	(1)	kPa	37	49	50	48	38	48
Water flow source side	(1)	l/h	3414	4073	4677	5286	6044	6760
Water pressure drop source side	(1)	kPa	7	9	7	9	7	8
Cooling and heating mode in total heat recovery								
Cooling capacity	(4)	kW	42,5	50,6	57,8	65,8	75,5	83,9
Heating capacity	(4)	kW	54,5	65,7	74,4	85,1	96,6	108
Total power input	(4)	kW	12,6	15,9	17,5	20,2	22,1	25,4
COP HRE	(4)		7,70	7,31	7,55	7,47	7,79	7,56
Water flow cooling side	(4)	l/h	7333	8735	9982	11357	13019	14474
Water pressure cooling heating side	(4)	kPa	27	36	36	35	27	34
Water flow heating side	(4)	l/h	9418	11336	12861	14684	16694	18668
Water pressure drop heating side	(4)	kPa	40	56	43	56	43	53
Heating mode operation								
Heating capacity	(5)	kW	59,4	71,5	81,1	92,4	105	118
Total power input	(5)	kW	12,8	16,2	17,8	20,5	22,4	25,6
COP	(5)		4,64	4,41	4,56	4,51	4,69	4,60
SCOP	(2)		4,16	4,30	4,38	4,31	4,36	4,21
Heating energy efficiency class	(6)		A+++					
Water flow user side	(5)	l/h	10253	12322	13994	15941	18139	20315
Water pressure drop user side	(5)	kPa	48	67	67	65	50	63
Water flow source side	(5)	l/h	8164	9694	11093	12594	14447	16114
Water pressure drop source side	(5)	kPa	31	43	33	42	33	40
General data								
Maximum current absorption		A	30	37	40	46	50	61
Star up current		A	111	156	158	181	178	186
Star up current with soft starter		A	73	84	97	106	119	134
Compressors / circuits			2 / 1					
Sound power level	(7)	dB(A)	72	72	73	73	74	76
Sound power level, low-noise version	(7)	dB(A)	68	68	69	69	70	72
Transport / operating weight		kg	410	420	450	460	490	510

(1) Water temperature - user side 12°C / 7°C, water temperature - dissipation side 15°C / 30°C (EN14511:2013)

(2) η efficiency values for heating and cooling are respectively calculated by the following formulas: $[\eta = SCOP / 2,5 - F(1) - F(2)]$ e $[\eta = SEER / 2,5 - F(1) - F(2)]$. For further information, please refer to the technical document "ErP 2009/125/EC DIRECTIVE" in the catalogue introducing pages, or to the EN14825:2017 regulation.

(3) Seasonal energy efficiency class for room cooling [EUROPEAN REGULATION No 2281/2016]

(4) Cooling water temperature 12°C / 7°C, recovery water temperature 40°C / 45°C (EN14511:2013)

(5) Water temperature - user side 40°C / 45°C, water temperature - source side 15°C / 10°C (EN14511:2013)

(6) Seasonal energy efficiency class for MEDIUM TEMPERATURE room heating under AVERAGE climatic conditions [EUROPEAN REGULATION No 811/2013]

(7) Sound power level measured according to ISO 9614

RATED TECHNICAL DATA FOR 4-PIPES SYSTEMS

LEP P			112	132	142	144	162	164
Power supply		V-ph-Hz	400 - 3N - 50					
Cooling mode operation								
Cooling capacity	(1)	kW	122	138	159	158	177	178
Total power input	(1)	kW	20,8	24,1	27,9	28,8	32,0	31,8
EER	(1)		5,84	5,75	5,69	5,49	5,53	5,60
SEER	(2)		6,40	6,38	6,31	6,07	6,17	6,19
Cooling efficiency class	(3)		AA					
Water flow user side	(1)	l/h	20958	23908	27403	27299	30542	30731
Water pressure drop user side	(1)	kPa	41	50	48	47	52	52
Water flow source side	(1)	l/h	8124	9280	10658	10673	11925	11979
Water pressure drop source side	(1)	kPa	7	9	8	8	9	9
Cooling and heating mode in total heat recovery								
Cooling capacity	(4)	kW	102	116	133	134	149	149
Heating capacity	(4)	kW	130	148	170	172	191	192
Total power input	(4)	kW	29,5	34,4	39,2	39,9	44,2	44,4
COP HRE	(4)		7,84	7,67	7,74	7,65	7,68	7,68
Water flow cooling side	(4)	l/h	17509	19938	22954	23050	25651	25738
Water pressure cooling heating side	(4)	kPa	30	36	35	35	38	38
Water flow heating side	(4)	l/h	22418	25636	29462	29671	33006	33122
Water pressure drop heating side	(4)	kPa	43	56	52	53	57	58
Heating mode operation								
Heating capacity	(5)	kW	141	161	185	186	208	208
Total power input	(5)	kW	29,8	34,7	39,5	40,3	44,7	45,0
COP	(5)		4,73	4,65	4,69	4,63	4,64	4,63
SCOP	(2)		4,29	4,24	4,29	4,34	4,28	4,28
Heating energy efficiency class	(6)		A+++					
Water flow user side	(5)	l/h	24385	27855	32009	32243	35854	35982
Water pressure drop user side	(5)	kPa	54	66	63	63	70	69
Water flow source side	(5)	l/h	19466	22145	25486	25584	28482	28558
Water pressure drop source side	(5)	kPa	34	43	40	40	44	45
General data								
Maximum current absorption		A	70	79	91	95	102	103
Star up current		A	240	248	291	219	302	220
Star up current with soft starter		A	178	186	226	170	237	171
Compressors / circuits			2 / 1	2 / 1	2 / 1	4 / 2	2 / 1	4 / 2
Sound power level	(7)	dB(A)	76	77	77	80	77	80
Sound power level, low-noise version	(7)	dB(A)	72	73	73	76	73	76
Transport / operating weight		kg	690	700	770	1010	830	1050

(1) Water temperature - user side 12°C / 7°C, water temperature - dissipation side 15°C / 30°C (EN14511:2013)

(2) η efficiency values for heating and cooling are respectively calculated by the following formulas: $[\eta = SCOP / 2,5 - F(1) - F(2)]$ e $[\eta = SEER / 2,5 - F(1) - F(2)]$. For further information, please refer to the technical document "ErP 2009/125/EC DIRECTIVE" in the catalogue introducing pages, or to the EN14825:2017 regulation.

(3) Seasonal energy efficiency class for room cooling [EUROPEAN REGULATION No 2281/2016]

(4) Cooling water temperature 12°C / 7°C, recovery water temperature 40°C / 45°C (EN14511:2013)

(5) Water temperature - user side 40°C / 45°C, water temperature - source side 15°C / 10°C (EN14511:2013)

(6) Seasonal energy efficiency class for MEDIUM TEMPERATURE room heating under AVERAGE climatic conditions [EUROPEAN REGULATION No 811/2013]

(7) Sound power level measured according to ISO 9614

Total heat recovery multi-purpose units LEP

RATED TECHNICAL DATA FOR 4-PIPES SYSTEMS

LEP P			182	184	204	214	243	244
Power supply		V-ph-Hz	400 - 3N - 50					
Cooling mode operation								
Cooling capacity	(1)	kW	211	206	223	243	272	284
Total power input	(1)	kW	37,0	35,4	38,5	41,5	47,0	46,7
EER	(1)		5,71	5,81	5,79	5,87	5,78	6,08
SEER	(2)		6,37	6,47	6,43	6,54	6,53	6,87
Cooling efficiency class	(3)		AA					
Water flow user side	(1)	l/h	36435	35502	38427	41971	46839	48896
Water pressure drop user side	(1)	kPa	46	45	51	49	51	33
Water flow source side	(1)	l/h	14171	13777	14922	16268	18194	18881
Water pressure drop source side	(1)	kPa	8	8	9	9	9	5
Cooling and heating mode in total heat recovery								
Cooling capacity	(4)	kW	177	172	186	204	230	238
Heating capacity	(4)	kW	226	219	238	260	292	302
Total power input	(4)	kW	51,3	49,7	54,5	58,8	65,3	66,7
COP HRE	(4)		7,85	7,87	7,79	7,87	7,98	8,09
Water flow cooling side	(4)	l/h	30513	29627	32115	35085	39581	40986
Water pressure cooling heating side	(4)	kPa	34	32	37	35	38	24
Water flow heating side	(4)	l/h	39076	37935	41197	44897	50482	52229
Water pressure drop heating side	(4)	kPa	51	49	57	54	58	34
Heating mode operation								
Heating capacity	(5)	kW	246	239	259	283	317	327
Total power input	(5)	kW	51,9	50,1	55,1	59,3	65,9	67,3
COP	(5)		4,73	4,77	4,71	4,77	4,81	4,86
SCOP	(2)		4,34	4,37	4,31	4,34	4,43	4,43
Heating energy efficiency class	(6)		A+++					
Water flow user side	(5)	l/h	42453	41353	44837	48891	54768	56606
Water pressure drop user side	(5)	kPa	61	59	68	64	67	44
Water flow source side	(5)	l/h	33846	33038	35730	39067	43844	45326
Water pressure drop source side	(5)	kPa	39	38	44	42	45	26
General data								
Maximum current absorption		A	140	174	221	116	153	184
Star up current		A	368	273	291	297	336	310
Star up current with soft starter		A	285	214	226	233	271	245
Compressors / circuits			2 / 1	4 / 2	4 / 2	4 / 2	3 / 1	4 / 2
Sound power level	(7)	dB(A)	78	81	81	81	81	82
Sound power level, low-noise version	(7)	dB(A)	74	77	77	77	77	78
Transport / operating weight		kg	890	1130	1280	1350	1850	1840

(1) Water temperature - user side 12°C / 7°C, water temperature - dissipation side 15°C / 30°C (EN14511:2013)

(2) η efficiency values for heating and cooling are respectively calculated by the following formulas: $[\eta = SCOP / 2,5 - F(1) - F(2)]$ e $[\eta = SEER / 2,5 - F(1) - F(2)]$. For further information, please refer to the technical document "ErP 2009/125/EC DIRECTIVE" in the catalogue introducing pages, or to the EN14825:2017 regulation.

(3) Seasonal energy efficiency class for room cooling [EUROPEAN REGULATION No 2281/2016]

(4) Cooling water temperature 12°C / 7°C, recovery water temperature 40°C / 45°C (EN14511:2013)

(5) Water temperature - user side 40°C / 45°C, water temperature - source side 15°C / 10°C (EN14511:2013)

(6) Seasonal energy efficiency class for MEDIUM TEMPERATURE room heating under AVERAGE climatic conditions [EUROPEAN REGULATION No 811/2013]

(7) Sound power level measured according to ISO 9614

RATED TECHNICAL DATA FOR 4-PIPES SYSTEMS

LEP P			283	284	314	344	374	424
Power supply		V-ph-Hz	400 - 3N - 50					
Cooling mode operation								
Cooling capacity	(1)	kW	313	317	348	381	414	475
Total power input	(1)	kW	55,0	54,9	63,3	68,4	73,5	80,5
EER	(1)		5,69	5,78	5,50	5,57	5,63	5,90
SEER	(2)		6,60	6,67	6,31	6,40	6,47	6,77
Cooling efficiency class	(3)		AA					
Water flow user side	(1)	l/h	53930	54637	60047	65714	71374	81840
Water pressure drop user side	(1)	kPa	39	40	48	47	46	48
Water flow source side	(1)	l/h	21010	21243	23495	25670	27842	31712
Water pressure drop source side	(1)	kPa	7	7	8	8	8	8
Cooling and heating mode in total heat recovery								
Cooling capacity	(4)	kW	263	266	294	321	348	396
Heating capacity	(4)	kW	336	340	378	411	446	508
Total power input	(4)	kW	76,5	77,3	88,1	95,1	102	118
COP HRE	(4)		7,83	7,85	7,62	7,70	7,77	7,68
Water flow cooling side	(4)	l/h	45343	45905	50624	55270	60024	68143
Water pressure cooling heating side	(4)	kPa	29	29	35	34	34	34
Water flow heating side	(4)	l/h	58202	58887	65356	71210	77195	87885
Water pressure drop heating side	(4)	kPa	42	44	53	52	51	51
Heating mode operation								
Heating capacity	(5)	kW	364	369	410	447	484	550
Total power input	(5)	kW	77,4	78,0	88,8	96,2	104	119
COP	(5)		4,71	4,73	4,61	4,64	4,66	4,62
SCOP	(2)		4,41	4,37	4,29	4,34	4,34	4,20
Heating energy efficiency class	(6)		A+++					
Water flow user side	(5)	l/h	63082	63868	70853	77301	83657	95146
Water pressure drop user side	(5)	kPa	52	53	65	63	61	63
Water flow source side	(5)	l/h	50157	50846	56099	61287	66384	75351
Water pressure drop source side	(5)	kPa	32	34	41	39	39	40
General data								
Maximum current absorption		A	234	120	161	207	281	130
Star up current		A	401	362	384	447	447	490
Star up current with soft starter		A	318	286	306	351	359	420
Compressors / circuits			3 / 1	4 / 2	4 / 2	4 / 2	4 / 2	4 / 2
Sound power level	(7)	dB(A)	81	82	82	83	83	83
Sound power level, low-noise version	(7)	dB(A)	77	78	78	79	79	79
Transport / operating weight		kg	1880	1940	2040	2110	2180	2380

(1) Water temperature - user side 12°C / 7°C, water temperature - dissipation side 15°C / 30°C (EN14511:2013)

(2) η efficiency values for heating and cooling are respectively calculated by the following formulas: $\eta = SCOP / 2,5 - F(1) - F(2)$ e $\eta = SEER / 2,5 - F(1) - F(2)$. For further information, please refer to the technical document "ErP 2009/125/EC DIRECTIVE" in the catalogue introducing pages, or to the EN14825:2017 regulation.

(3) Seasonal energy efficiency class for room cooling [EUROPEAN REGULATION No 2281/2016]

(4) Cooling water temperature 12°C / 7°C, recovery water temperature 40°C / 45°C (EN14511:2013)

(5) Water temperature - user side 40°C / 45°C, water temperature - source side 15°C / 10°C (EN14511:2013)

(6) Seasonal energy efficiency class for MEDIUM TEMPERATURE room heating under AVERAGE climatic conditions [EUROPEAN REGULATION No 811/2013]

(7) Sound power level measured according to ISO 9614

DIMENSIONAL DRAWINGS

LEP 042 - 092

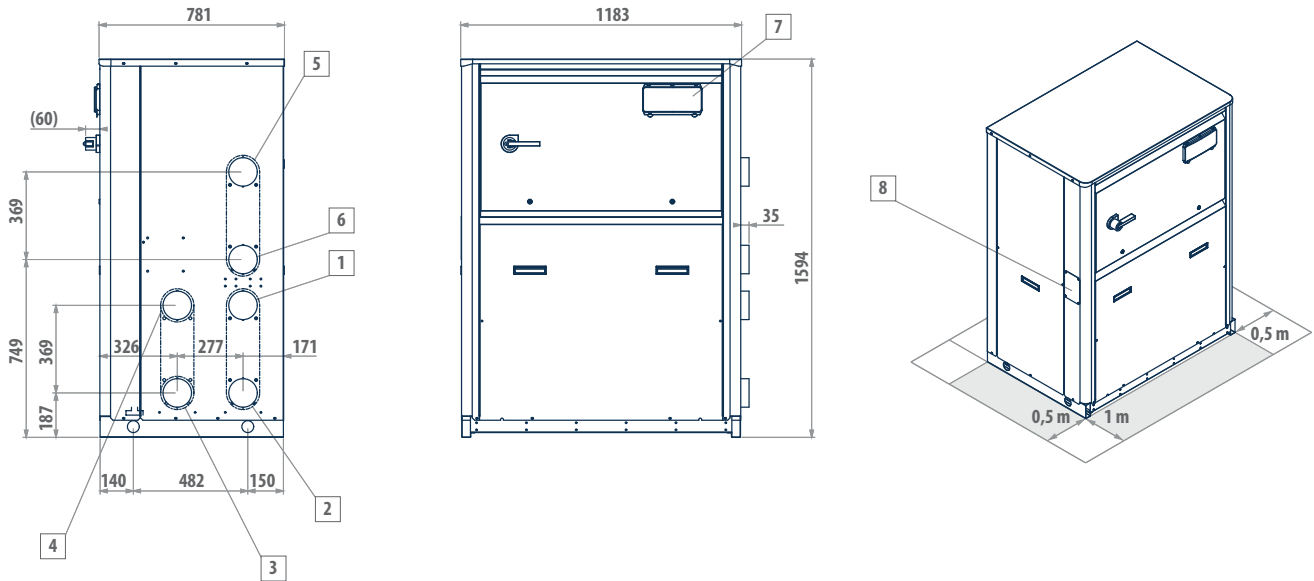

LEGEND

1	User side - inlet (Victaulic 2 ½")
2	User side - outlet (Victaulic 2 ½")
3	DHW side - inlet (Victaulic 2 ½")
4	DHW side - outlet (Victaulic 2 ½")
5	Dissipation side - inlet (Victaulic 2 ½")
6	Dissipation side - outlet (Victaulic 2 ½")
7	User interface
8	Power supply input

MODEL VERSION

LEP 042	M-P	S-L
LEP 052	M-P	S-L
LEP 062	M-P	S-L
LEP 072	M-P	S-L
LEP 082	M-P	S-L
LEP 092	M-P	S-L

DIMENSIONAL DRAWINGS

LEP 112 - 182

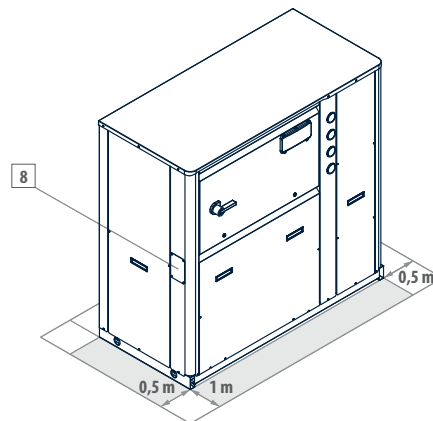
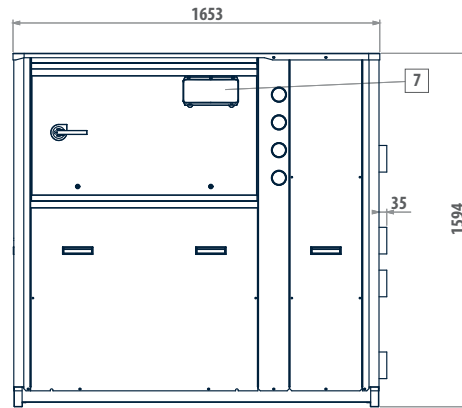
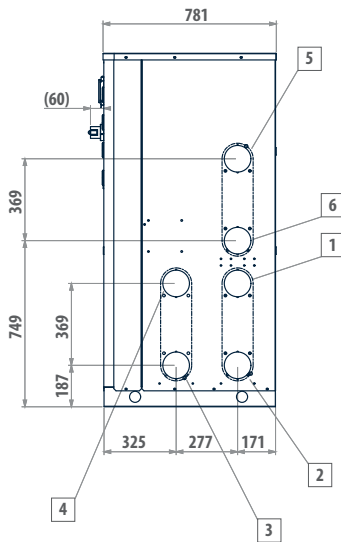

LEGEND

1	User side - inlet (Victaulic 2 ½")
2	User side - outlet (Victaulic 2 ½")
3	DHW side - inlet (Victaulic 2 ½")
4	DHW side - outlet (Victaulic 2 ½")
5	Dissipation side - inlet (Victaulic 2 ½")
6	Dissipation side - outlet (Victaulic 2 ½")
7	User interface
8	Power supply input

MODEL VERSION

LEP 112	M-P	S-L
LEP 132	M-P	S-L
LEP 142	M-P	S-L
LEP 162	M-P	S-L
LEP 182	M-P	S-L

Total heat recovery multi-purpose units LEP

DIMENSIONAL DRAWINGS

LEP 144 - 184

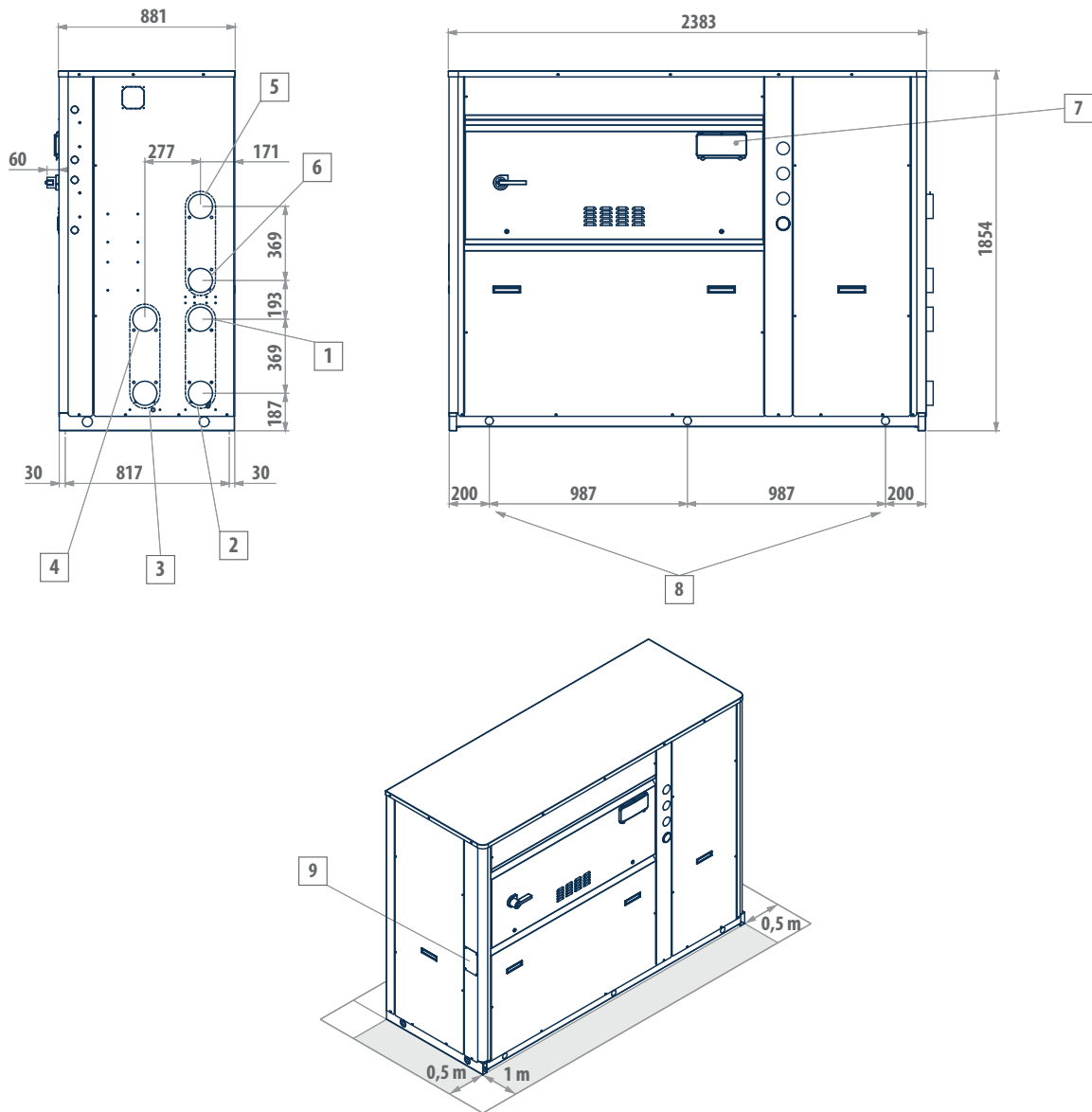

LEGEND

1	User side - inlet (Victaulic 2 ½")
2	User side - outlet (Victaulic 2 ½")
3	DHW side - inlet (Victaulic 2 ½")
4	DHW side - outlet (Victaulic 2 ½")
5	Dissipation side - inlet (Victaulic 2 ½")
6	Dissipation side - outlet (Victaulic 2 ½")
7	User interface
8	Lifting points
9	Power supply input

MODEL VERSION

LEP 144	M-P	S-L
LEP 164	M-P	S-L
LEP 184	M-P	S-L

DIMENSIONAL DRAWINGS

LEP 204 - 214

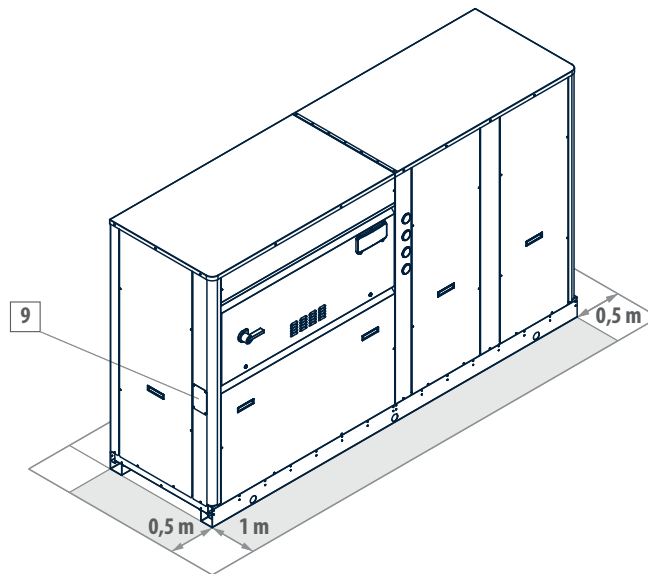
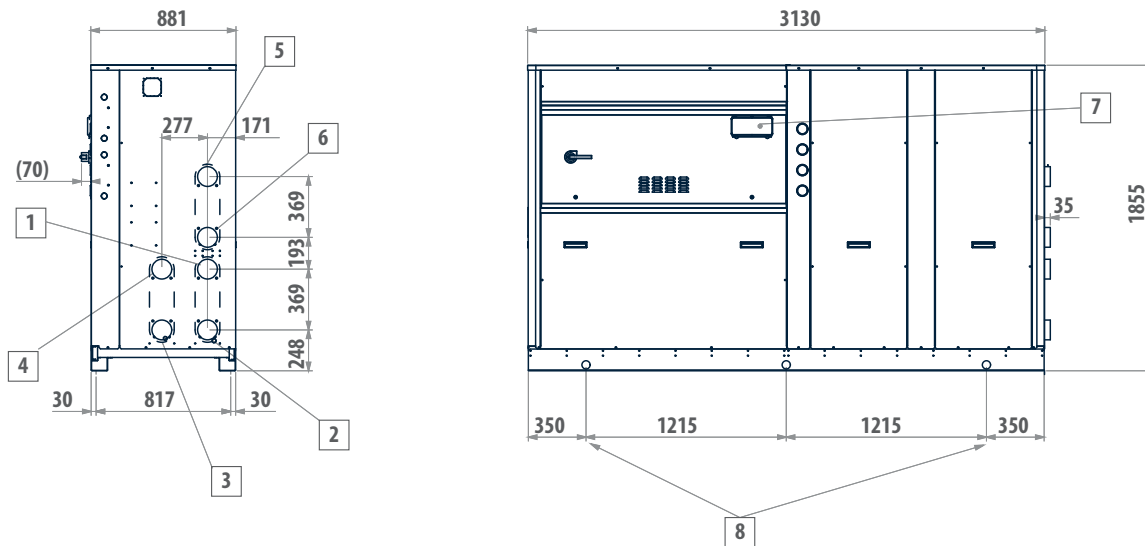

LEGEND

1	User side - inlet (Victaulic 2 ½")
2	User side - outlet (Victaulic 2 ½")
3	DHW side - inlet (Victaulic 2 ½")
4	DHW side - outlet (Victaulic 2 ½")
5	Dissipation side - inlet (Victaulic 2 ½")
6	Dissipation side - outlet (Victaulic 2 ½")
7	User interface
8	Lifting points
9	Power supply input

MODEL	VERSION	
LEP 204	M-P	S-L
LEP 214	M-P	S-L

Total heat recovery multi-purpose units LEP

DIMENSIONAL DRAWINGS

LEP 243 - 424

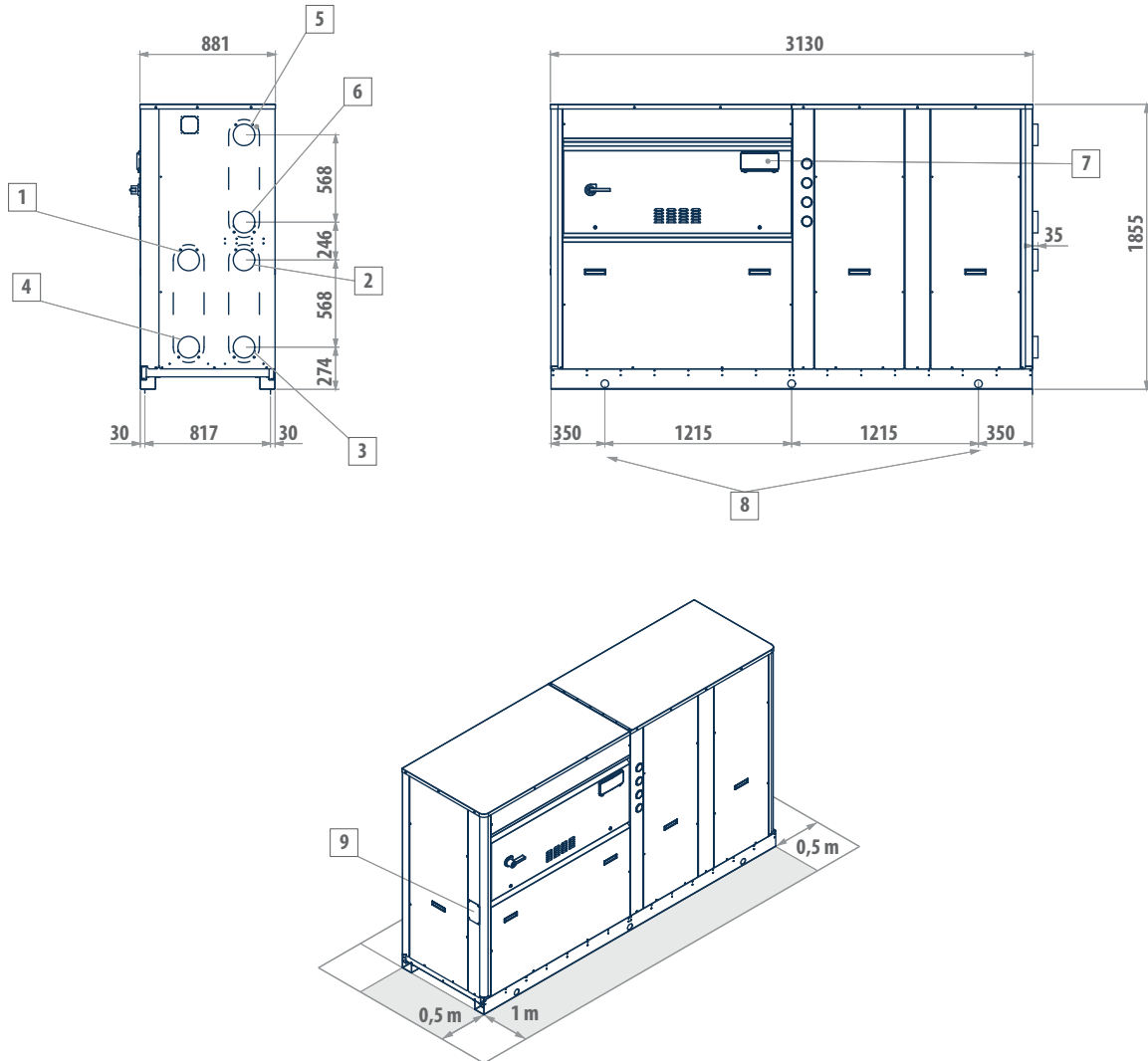

LEGEND

1	User side - inlet (Victaulic 2 ½")
2	User side - outlet (Victaulic 2 ½")
3	DHW side - inlet (Victaulic 2 ½")
4	DHW side - outlet (Victaulic 2 ½")
5	Dissipation side - inlet (Victaulic 2 ½")
6	Dissipation side - outlet (Victaulic 2 ½")
7	User interface
8	Lifting points
9	Power supply input

MODEL VERSION

LEP 243	M-P	S-L
LEP 244	M-P	S-L
LEP 283	M-P	S-L
LEP 284	M-P	S-L
LEP 314	M-P	S-L
LEP 344	M-P	S-L
LEP 374	M-P	S-L
LEP 424	M-P	S-L



SYSTEM AND ACCESSORIES CONTROLLERS

Introduction	p. 348
EVOSYSTEM	p. 350
ACCUMULI	p. 352



System solutions

Energy saving

Galletti offers a ten-years long experience in air-conditioning systems at the service of professionals. The primary purpose is our customer's satisfaction in terms of comfort and energy savings.

An efficient system in its fundamental components (hydronic indoor units and heat pumps) cannot exclude an intelligent management. The system controls guarantee an optimal adjustment of the system, enhancing the strong points of single elements and combining their operation in order to reduce consumed energy to its lowest terms. Galletti is capable of managing systems with heat pumps (also multi-purpose ones) and possible auxiliary generators: by continuously monitoring the system operating conditions, the software automatically makes choices to guarantee an optimal level of comfort and to use the most efficient system at hand in every moment.

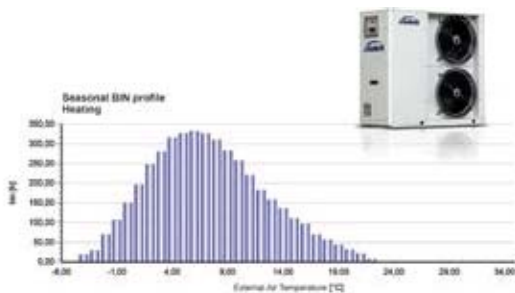

Stratification

Thermal accumulations are fundamental for the optimal management of systems, especially when there is a production of cold and hot water per each system and domestic hot water through different power units. A proper stratification of the water inside thermal storage guarantees considerable advantages in the management of the system. Specifically, keeping water at a higher temperature in the upper section and at a colder temperature in the lower section allows us to withdraw water for the system (even more importantly for domestic use) at the highest temperature available and to withdraw colder water, treated by the heat pump, from the lower section. In this way, the efficiency of the heat pump is maximized as well as the perception of comfort by the users.

In order to guarantee a correct stratification, Galletti offers thermal storage tanks equipped with labyrinth diffusers to produce domestic hot water. For inertial accumulations, Galletti offers a double 4-way valve solution to allow the system to send hot water to the upper section and withdraw it from the same section during winter, switching the flow and its withdrawal during summer.

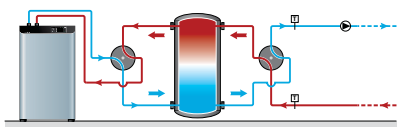
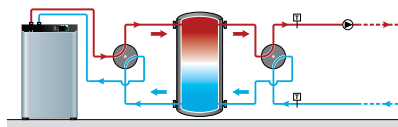



Thermal inertia in multi-purpose systems

Multi-purpose systems require particular attention when being designed. A fundamental element is the tank used for the production of domestic hot water. Galletti chose the solution "thermal storage tank of technical water" and "rapid" production of DHW through external plate heat exchanger or internal coil. In this way, it is possible to optimize the thermal exchange of the heat pump guaranteeing a better thermal exchange also in terms of stratification and, at the same time, eliminating the need of anti-legionella cycles since domestic hot water is not stored.

The collaboration with Cordivari, leader company in the tank field, led to the development of a range specifically created to operate with multi-purpose units in residential areas.

In this way, maximum comfort can be guaranteed to the end user, designers and technicians as well as the safety of an optimal system from every point of view.

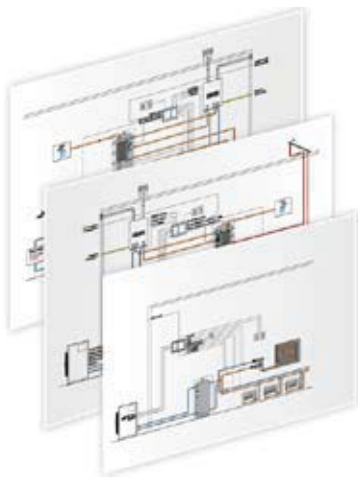

Flexibility

The controls and the system accessories offer the necessary tools for designers and technicians to develop a cutting edge system for the specific requests of their customers. The great flexibility of the Galletti's offer allows a management of systems with heat pumps with external 3-way valves for the production of hot and cold water for the system or domestic hot water, multi-purpose heat pumps with total recovery, tanks, pumps, valves, auxiliary power units and radiant systems.

Through the system controls and the available accessories, Galletti puts its experience in air-conditioning systems by providing a mix of solutions able to offer a reliable and suitable systems to its end user.



In-house software development

Constant improvement is at the bottom of the management softwares developed in Galletti's Technical Department. The offered adjustment is perfectly integrated with catalogued heat pumps by using a serial type communication on RS485 network or through potential no-voltage contacts.

The possibility to use different modes of communication together with the complete control of management dynamics makes Galletti's offer versatile and optimal not only for single products but also for different systems' solutions.

Electronic microprocessor controller for integrated system management

EVO SYSTEM



Intelligence and control at the service of the system

Comfort, energy savings, intelligence, and control are only some of the factors that have contributed to the creation of this microprocessor controller. EVO SYSTEM meets the need to develop an efficient generation system, not only with regard to its basic components, but especially their integration.

The regulations in force have finally diverted attention away from the prompt functioning of the heat pump (for example, its performance at the nominal point) to its behaviour in the seasonal period. To accomplish this it is necessary to take into account the variation of external conditions and the building-specific requirements, any other generation systems present in the system, and especially the management by the regulating system.

Today, finally Galletti concentrates its expertise into a unique product that is able to manage the basic components of a generation system, thereby automatically and intelligently guaranteeing excellent comfort without worries for the user, with maximum energy savings.

The integrated and synergistic management of the system is distilled into one word: EVO SYSTEM

Touch interface (available on request) - The touch screen wall interface is an intuitive synoptic that allows the user to continuously monitor storage temperatures, alarms, activations of the various generators and much more, ensuring control of the thermal power plant and the possibility of adapting the operation to your needs with a simple touch.



PLUS

- » Integrated management of dual systems
- » Selection of the most advantageous generator
- » Communication with ERGO
- » Dew point check
- » Touch interface available on request

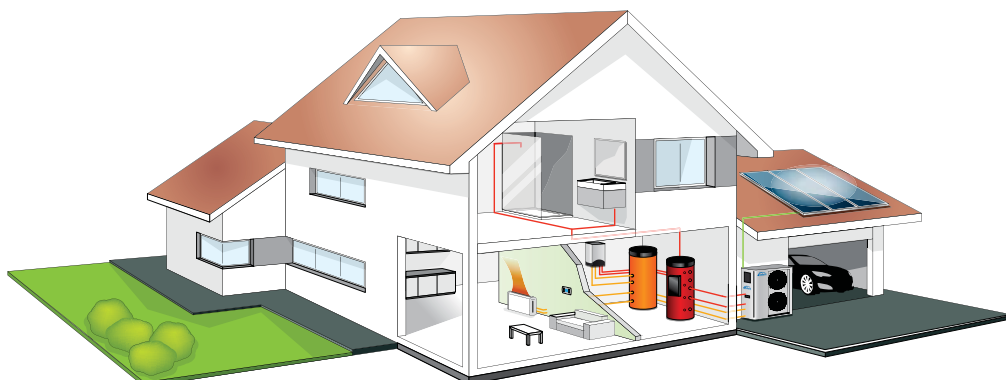

MAIN FUNCTIONS
Universal controller

The decision to set communication by means of clean contacts and analog outputs 0-10 V is based on a logic of flexibility that serial communication would be unable to offer. Specifically, the controller can interface with Galletti's entire range of heat pumps, auxiliary generators such as boilers, enclosed fireplaces, biomass burners, valves, circulators, and modulating actuators of various types.

Dew point

The controller is able to evaluate the relative humidity of a room and automatically calculate the dew point. This calculation is used to adjust the outlet set point of a mixed branch: this ensures that the water that feeds the radiant emitters is at a temperature high enough to avoid any condensation of water vapour in the air.

Compensation

The sensors connected to the regulator make it possible to manage one or more climatic curves on the system's different branches. This function allows the system to be connected to different types of indoor units controlling modulating actuators such as mixing valves to manage different outlet temperatures. This function ensures energy savings and the optimal operation of the emitters in connection with the building's thermal load.

Intelligent management of the tanks

In heat pump systems or with multi-purpose system in which a further generator is present, the temperature in the tanks is managed in order to maximize the use of the heat pump, and the integration system is activated only if necessary.

Emergency actions

The call to the integration system is made sooner if defrosting is underway, according to an innovative derivative logic that is able to evaluate, according to the speed of change of the water buffer tank's temperature, the presence of an event outside of the project criteria or unusual thermal loads.

SYNERGY WITH SENECA
Seneca

The system can be evaluated in the design phase by means of Seneca, web-based software developed by Galletti's R&D department, which is able to take into account:

- the specific Galletti heat pump and its behaviour under the various conditions
- the exact location of installation, which is matched with the seasonal thermal loads based on the BINs method
- the envelope, evaluated through the energy signature.

Cost effectiveness

Seneca's output is used in the EVO SYSTEM regulator to replicate, during actual operation, the optimal conditions simulated during the design phase. The constant monitoring of the outside temperature allows the controller to select the most advantageous system from an energy or economical point of view. The internal logics, combined with savings, ensure optimal comfort for the user.

Cut-off

In the dual systems, in which the heat pump power is combined with other heat sources, Seneca defines a cut-off temperature at which it is economically or energetically advantageous to use an alternative system to the heat pump.

INTEGRATION WITH ERGO
Communication

EVO SYSTEM makes it possible to manage the entire generation system from the user interface. Furthermore, serial communication via the Modbus protocol makes the controller perfectly compatible with external supervisors such as ERGO. This product completes Galletti's range of system controllers, guaranteeing the user integrated management of all the components of the air-conditioning system. Synergy, savings, and comfort with EVO SYSTEM.

ACCESSORIES
EYMCUSUE

The humidity sensor is connected to the power board and is designed for insertion in the rear space of the user interface (in a dedicated recess). The relative humidity value is calculated from the absolute humidity measured by the sensor and the dry-bulb temperature measured by the air sensor that is already integrated in the user interface.

Thermal storage tank for the production of domestic hot water

RYT 300 - 800 l



Advanced technology in the accumulation of technical water for the production of domestic hot water

This range of products combines Galletti's solid experience in the operation of heat pumps and in the logics for managing multi-purpose systems with Cordivari's experience in developing tanks.

To maximize system efficiency, Galletti decided to give priority to the thermal storage tank logic (storage of technical water in the tank) over the boiler logic (storage of domestic hot water). In this manner it is not necessary to include the anti-*Legionella* cycle, which is normally executed by means of a thermal shock (which implies a loss in the system's efficiency) or a chemical treatment.

The range consists of two product lines, the first product line includes thermal storage tanks with a stainless steel coil for the immediate production of domestic hot water and the second one consists of thermal storage tanks combined with an external plate exchanger and mixing valve for the production of domestic hot water at a fixed temperature.

PLUS

- » Labirinth diffuser (patented) for an optimal stratification
- » Increased exchange surfaces for the production of DHW at an optimal temperature
- » External insulation in polyurethane foam or high-thickness polyester
- » No need of anti-*legionella* cycles
- » Presence of traps for probes at different height levels

RYTN / RYTNSH

Thermal storage tanks with a stainless steel coil for the immediate production of domestic hot water.

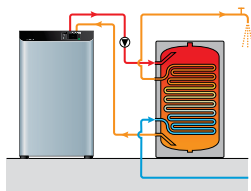

RYTP / RYTPSH

Thermal storage tanks combined with an external plate exchanger for the immediate production of domestic hot water.

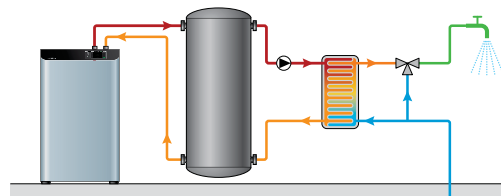

ACCESSORIES

Size	RYR02M 2 kW - 220 V single-phase	RYR03M 3 kW - 220 V single-phase	RYR06T 6 Kw - 400 v three-phase	RYR12T 6 kW - 400 V three-phase
300l	x	x	-	-
500l	x	x	x	-
800l	x	x	x	x

AVAILABLE VERSIONS



RYTN

RYTN storage tanks are designed to store heating system water. Domestic water is made to pass inside a stainless steel corrugated coil. Inside the thermal storage tank, in the connections used for the heat pumps, there is a labyrinth diffuser (patented): this element guarantees the maintenance of the stratification regardless of the joint used for the flow of technical water coming from the heat pump.



RYTNSH

RYTNSH storage tanks are designed to store heating system water. Domestic water is made to pass inside a stainless steel corrugated coil. They are also provided with additional charging coils to enable use of heat originating from solar thermal panels or other high temperature sources of heat such as, for example, fireplace heaters, biomass generators, etc. Inside the thermal storage tank, in the connections used for the heat pumps, there is a labyrinth diffuser (patented): this element guarantees the maintenance of the stratification regardless of the joint used for the flow of technical water coming from the heat pump.

RATED TECHNICAL DATA RYTN

RYTN		300l	500l	800l
Net storage volume	l	291	454	748
Domestic water circuit volume	l	7	32	45
Surface area of corrugated coil	m ²	4	6	8
Unit weight	kg	62	95	120
Maximum pressure thermal storage tank	bar	3	3	3
Maximum temperature thermal storage tank	°C	99	99	99
DHW coil maximum pressure	bar	6	6	6

RATED TECHNICAL DATA RYTNSH

RYTNSH		300l	500l	800l
Net storage volume	l	291	454	748
Domestic water circuit volume	l	7	32	46
Surface area of corrugated coil	m ²	4	6	8
Volume of lower fixed coil	l	8	13	16
Surface area of lower fixed coil	m ²	1	2	3
Volume of upper fixed coil	l	6	8	11
Surface area of upper fixed coil	m ²	1	1	2
Unit weight	kg	85	132	169
Maximum pressure thermal storage tank	bar	3	3	3
Maximum temperature thermal storage tank	°C	99	99	99
DHW coil maximum pressure	bar	6	6	6
Maximum pressure solar coil at high temperature	bar	12	12	12
Maximum temperature solar coil at high temperature	°C	110	110	110

System and accessories controllers RYT



RYT

RYT storage tanks are equipped with an external module that instantly heats domestic water by exploiting the heat stored in the puffer, ensuring hygiene and comfort as well as the possibility of regulating the outlet temperature. The module consists of a stainless steel plate exchanger, an on/off pump and a 3-way valve for temperature-controlled pre-mixing on the exchanger inlet (primary side), which prevents excessively high temperatures in the exchanger itself while considerably reducing the risk of limescale build-up.



RYTPSH

RYTP storage tanks are equipped with an external module that instantly heats domestic water by exploiting the heat stored in the puffer, ensuring hygiene and comfort as well as the possibility of regulating the outlet temperature. The module consists of a stainless steel plate exchanger, an on/off pump and a 3-way valve for temperature-controlled pre-mixing on the exchanger inlet (primary side), which prevents excessively high temperatures in the exchanger itself while considerably reducing the risk of limescale build-up.

They are also provided with additional charging coils to enable use of heat originating from solar thermal panels or other high temperature sources of heat such as, for example, fireplace heaters, biomass generators, etc.

RATED TECHNICAL DATA RYP

RYTP			300l	500l	800l
Net storage volume		l	286	478	803
Maximum power DHW module	(1)	kW	120	120	120
Unit weight		kg	106	126	152
Maximum pressure thermal storage tank		bar	3	3	3
Maximum temperature thermal storage tank		°C	99	99	99
Maximum pressure stainless steel plate heat exchanger		bar	6	6	6
Maximum temperature stainless steel plate heat exchanger		°C	99	99	99

(1) Maximum power referring to a storage temperature of 80°C

RATED TECHNICAL DATA RYTPSH

RYTPSH			300l	500l	800l
Net storage volume		l	278	456	775
Maximum power DHW module	(1)	kW	120	120	120
Volume of lower fixed coil		l	8	14	16
Surface area of lower fixed coil		m ²	1	2	3
Volume of upper fixed coil		l	4	7	14
Surface area of upper fixed coil		m ²	1	1	2
Unit weight		kg	106	162	205
Maximum pressure thermal storage tank		bar	3	3	3
Maximum temperature thermal storage tank		°C	99	99	99
Maximum pressure solar coil at high temperature		bar	12	12	12
Maximum temperature solar coil at high temperature		°C	110	110	110
Maximum pressure stainless steel plate heat exchanger		bar	6	6	6
Maximum temperature stainless steel plate heat exchanger		°C	99	99	99

(1) Maximum power referring to a storage temperature of 80°C

DIMENSIONAL DRAWINGS

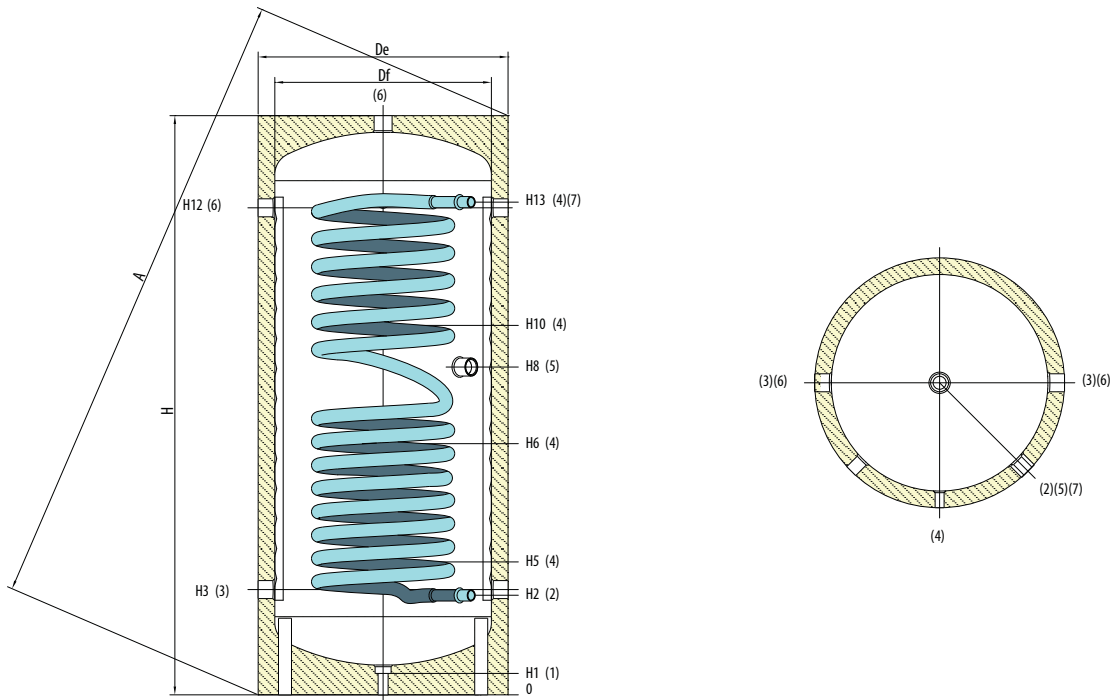
RYTN

CONNECTIONS

1	Outlet 1" 1/4 gas F
2	Domestic cold water inlet
3	Heating return to generator 1" 1/2 Gas F
4	Connection for instrumentation - 1/2" Gas F
5	Electrical immersion 1" 1/2 Gas F
6	From Generator - Heating delivery 1" 1/2 Gas F
7	Domestic water outlet

* in the presence of a second high temperature generator that works directly on the top of the storage tank

WARNING: We suggest not to use the connection on the top of the tank as the heat pump outlet (or other high temperature heat generator) as this will ruin the stratification.

WARNING: We recommend to use this tank only for domestic hot water production and not for heating the technical water of the plant, which should have a dedicated storage.

Mod.	Df mm	De mm	H mm	A mm	H1 mm	H2 mm	H3 mm	H5 mm	H6 mm	H8 mm	H10 mm	H12 mm	H13 mm	2-11
RYTN300	550	650	1585	1713	70	297	330	390	745	970	1100	1280	1315	1/2" GAS F
RYTN500	650	750	1745	1899	70	305	322	405	760	990	1115	1468	1485	1" GAS M
RYTN800	790	940	1940	2156	70	325	342	425	780	935	1135	1618	1635	1" GAS M

DIMENSIONAL DRAWINGS

RYTNSH

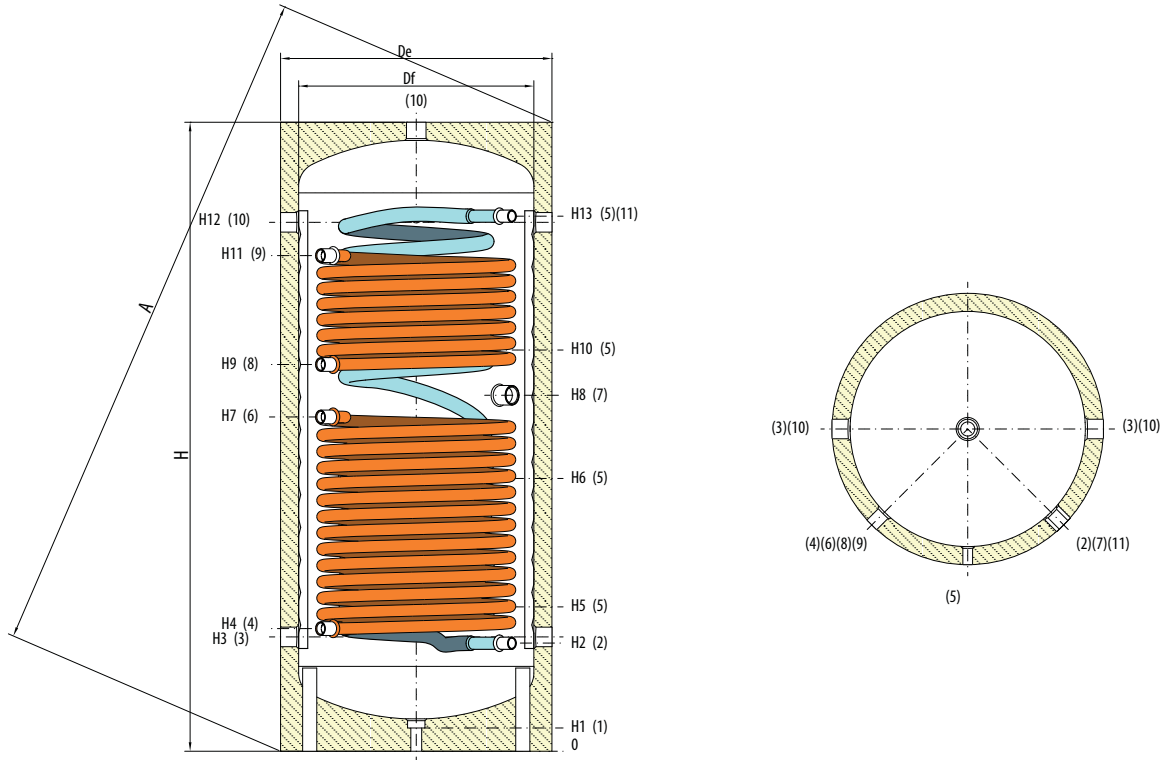

CONNECTIONS

1	Outlet 1" 1/4 gas F	9	Upper fixed heat exchanger - 1" Gas F
2	Domestic cold water inlet	10	From Generator - Heating delivery 1" 1/2 Gas F
3	Heating return to generator 1" 1/2 Gas F	11	Domestic water outlet
4	Lower fixed heat exchanger - 1" Gas F		
5	Connection for instrumentation - 1/2" Gas F		
6	Lower fixed heat exchanger - 1" Gas F		
7	Electrical immersion 1" 1/2 Gas F		
8	Upper fixed heat exchanger outlet - 1" Gas F		

⚠ WARNING: We suggest not to use the connection on the top of the tank as the heat pump outlet (or other high temperature heat generator) as this will ruin the stratification.

⚠ WARNING: We recommend to use this tank only for domestic hot water production and not for heating the technical water of the plant, which should have a dedicated storage.

Mod.	Df mm	De mm	H mm	A mm	H1 mm	H2 mm	H3 mm	H4 mm	H5 mm	H6 mm	H7 mm	H8 mm	H9 mm	H10 mm	H11 mm	H12 mm	H13 mm	2-11
RYTNSH300	550	650	1585	1713	70	297	330	330	390	754	870	970	1040	1100	1280	1280	1315	1/2" GAS F
RYTNSH500	650	750	1745	1899	70	305	322	345	405	760	930	990	1075	1115	1375	1468	1485	1" GAS M
RYTNSH800	790	940	1940	2156	70	325	342	365	425	780	905	935	1065	1135	1409	1618	1635	1" GAS M

DIMENSIONAL DRAWINGS

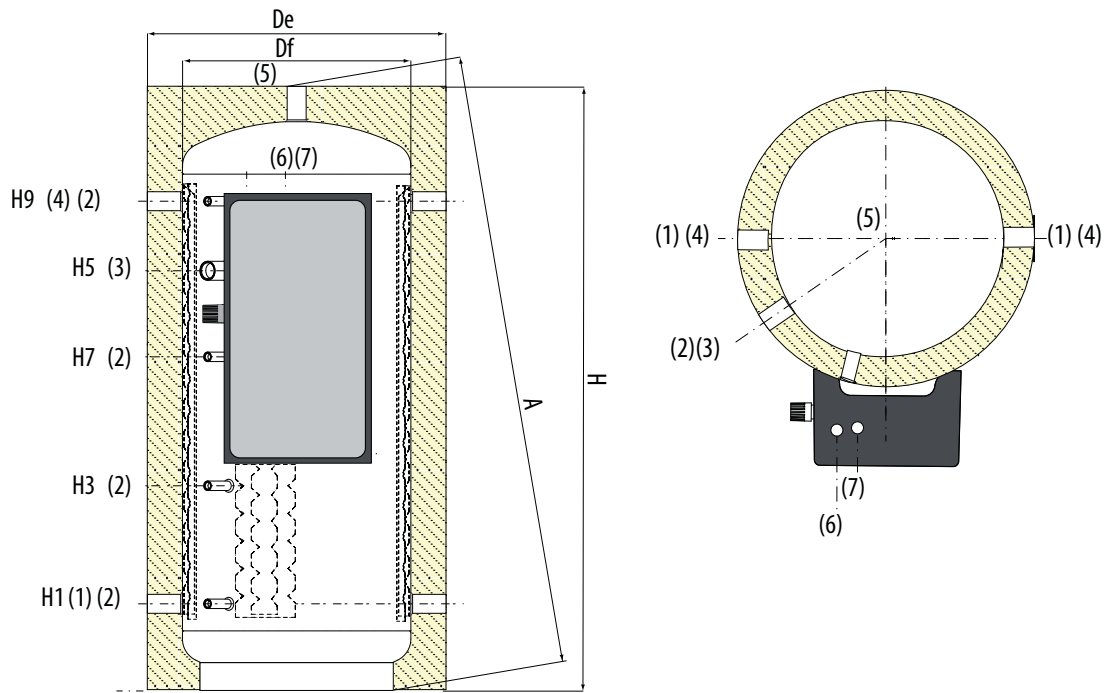
RYTP 300

CONNECTIONS

1	Heating return to generator 1"1/2 Gas F
2	Connection for instrumentation - 1/2" Gas F
3	Electrical immersion 1"1/2 Gas F
4	From Generator - Heating delivery 1"1/2 Gas F
5	Heating delivery 1"1/2 Gas F
6	Domestic cold water inlet
7	(DHW) Domestic hot water exit

* in the presence of a second high temperature generator that works directly on the top of the storage tank

WARNING: We suggest not to use the connection on the top of the tank as the heat pump outlet (or other high temperature heat generator) as this will ruin the stratification.

WARNING: We recommend to use this tank only for domestic hot water production and not for heating the technical water of the plant, which should have a dedicated storage.

Mod.	Df mm	De mm	H mm	A mm	H1 mm	H3 mm	H5 mm	H7 mm	H9 mm
RYTP300	550	650	1310	1344	232	425	855	625	1048
RYTP500	650	650	1619	1666	247	583	1124	841	1343
RYTP800	790	940	1838	1885	265	613	1338	1038	1541

DIMENSIONAL DRAWINGS

RYTPSH 500 - 800

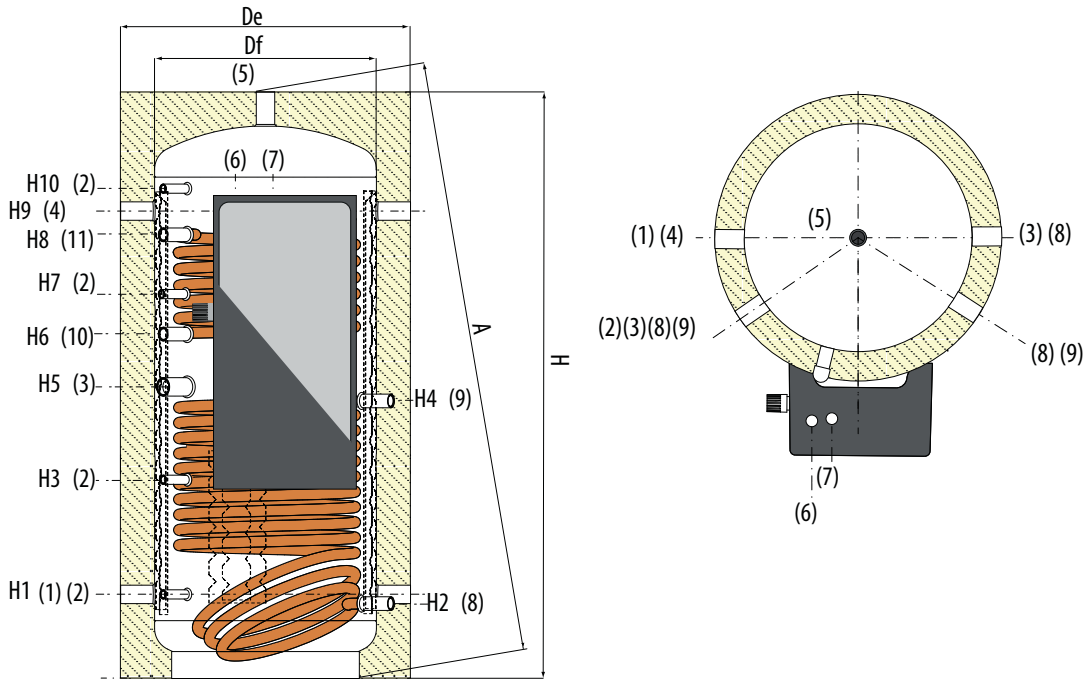

CONNECTIONS

1	Heating return to generator 1" 1/2 Gas F	9	Lower heat exchanger - 1" Gas F
2	Connection for instrumentation - 1/2" Gas F	*	in the presence of a second high temperature generator that works directly on the top of the storage tank
3	Electrical immersion 1" 1/2 Gas F		
4	From Generator - Heating delivery 1" 1/2 Gas F	⚠ WARNING:	We suggest not to use the connection on the top of the tank as the heat pump outlet (or other high temperature heat generator) as this will ruin the stratification.
5	Heating delivery 1" 1/2 Gas F	⚠ WARNING:	We recommend to use this tank only for domestic hot water production and not for heating the technical water of the plant, which should have a dedicated storage.
6	Domestic cold water inlet		
7	(DHW) Domestic hot water exit		
8	Upper heat exchanger outlet - 1" Gas F		

Mod.	Df mm	De mm	H mm	A mm	H1 mm	H2 mm	H3 mm	H4 mm	H5 mm	H6 mm	H7 mm	H8 mm	H9 mm	H10 mm
RYTPSH300	550	650	1310	1344	232	195	425	604	645	762	870	1002	1048	1085
RYTPSH500	650	750	1669	1666	247	260	583	854	904	1010	1124	1301	1393	1430
RYTPSH800	790	940	1836	1885	265	265	613	749	898	1020	1138	1347	1541	1578



HEAT RECOVERY UNIT

Introduction p. 362

RPE p. 364



COMPANY

EXPERIENCE AND FLEXIBILITY IN AIR TREATMENT FOR CIVIL AND INDUSTRIAL AIR CONDITIONING.

Cetra was founded at the end of the '70s in a small 300 sqm. warehouse where, thanks to skill acquired from previous experience in the air conditioning sector, the first thermo-ventilating units (TVU) were manufactured for the local market.

In the mid '80s one of the founders patented the technical solution that everyone in the sector knows today as the 3-way joint, the pivotal development that made it possible to build modular TVUs from that point on. At the same time they began to develop their first relationships with the major companies in the sector (Carrier, Marelli), making it possible, over the following decades, for the company to establish itself in Italy as one of the standard-setting businesses in the air treatment sector, and to expand into the international market.

Becoming part of Galletti group boosted the company's growth, thanks to beneficial synergies with other companies in the Group, creating cross-competences and technological solutions. Throughout this significant evolution, Cetra has maintained the typical values of a family-run business, where work is considered a trade, and is therefore a guarantee for excellent quality. Today, within Galletti Group, Cetra is the leader of the air treatment market for the residential and tertiary sectors, with a complete range of Eurovent-certified products. The air treatment facilities can be set so that the customer has the option of integrating them with any of the Galletti Group products. The company has developed relevant technical skills in specific sectors, such as pharmaceutical, hospital and food.

The Cetra production facility in Altedo (BO) houses a sheet metal processing division, an extensive production line divided into 6 different areas, each one dedicated to a specific sector, and a complete testing line for all of the units.

Following the Galletti Group philosophy of managing all of the production process phases in-house, today Cetra is known on the market as one of the most flexible and dynamic companies in the air treatment industry. It is known for being able to fulfil the specific requests of its stakeholders, confirmed by the addition of the rooftop air-to-air monobloc independent air conditioner in the Cetra product catalogue.

HEAT RECOVERY UNIT

RPE S

9 models
2 configurations
Cross flow heat exchanger
By pass free cooling
AC /EC motor
Efficiency 90%

Air flow:
from 500 to 6000 mc/h



RPE X

9 models
2 configurations
Cross flow heat exchanger
By pass free cooling
EC motor
Efficiency 90%

Air flow:
from 500 to 6000 mc/h

HEAT RECOVERY UNIT

RRE

5 models
2 configurations
Recovery wheel
AC /EC motor
Efficiency 80 %

Air flow:
from 300 to 3500 mc/h



THERMOVENTILATING

THT

7 models
Horizontal installation
2 or 4 pipes system
AESP up to 300 pa
Pulley fan belt

Air flow:
from 100 to 20000 mc/h
Cooling/heating capacity:
from 5 to 150 kWn



TVT

7 models
Vertical installation
2 or 4 pipes system
AESP up to 300 pa
Pulley fan belt

Air flow:
from 100 to 20000 mc/h
Cooling/heating capacity:
from 5 to 150 KW



EXTRACTORS

TE, TCE

7 models
4 configuration
AC motor/ Pulley fan belt
AESP up to 300 pa

Air flow:
from 100 to 20000 mc/h



AHU

CT

39 models
Completely customized
Indoor or outdoor installation

Air flow:
from 1000 to 100000 mc/h



ADJUSTABLE AHU

CTR

39 models
Complete with regulation
Completely customized
Indoor or outdoor installation

Air flow:
from 1000 to 100000 mc/h



UTX EUROVENT

UTX

39 models
Eurovent certification
Completely customized
Installation indoor or outdoor

Air flow:
from 1000 to 100000 mc/h



AHU POOL APPLICATION

CTP

39 models
Pre-painted component
Chlorine resistant
Completely customized
Indoor or outdoor installation

Air flow:
from 1000 to 100000 mc/h



CTA HOSPITAL APPLICATION

CTH

39 models
Component AISI 316
Sanification unit
Completely customized
Indoor or outdoor installation

Air flow:
from 1000 to 100000 mc/h



AHU FOOD APPLICATION

CTF

39 models
Component AISI 316
Mineral wool insulation
Completely customized
Indoor or outdoor insulation

Air flow:
from 1000 to 100000 mc/h



SANIFICATION IONIZATION SYSTEM

JONIX

Sanification ionization system
Non-thermal plasma technology
Class 1 medical device
according to 93/42 CEE
European directive
**Installation allowed
in all Cetra products**



ROOFTOP

CRT rooftop

7 models
Blid compressor
Plug fan EC
Heat recovery
**Cooling-heating
capacity:**
from 20 to 80 KW



SYSTEM CONTROL

EVO/TED

pCO
advanced
control



Mechanical ventilation units with heat recovery

RPE 500 - 6000 mc/h



Static upstream-flow heat recovery unit, made of aluminum, with high efficiency (90%)

The units of the RPE series for air recirculation and heat recovery, available in 2 versions (RPE-S and RPE-X) and 9 models are characterized by closing panels made of a double sheet of galvanized steel, pre-painted on the outer surface, completely removable for inspection/maintenance, and with different inlet/outlet configurations.

Internal heat and sound insulation made from polyurethane foam or mineral wool with a thickness of 30 mm.

Ventilation sections with directly coupled electric fans with motor AC or BLDC.

Upstream-flow heat recovery, with aluminium or pre-painted alluminium heat exchanger sealed at the ends in order to prevent contamination of the fresh air.

Bypass/free cooling dampers inserted inside the unit controlled by the EVO control system (standard on RPE-X series). F7 filter on the outlet (F9 optional) and M6 on the intake.

Condensate collection and drainage container constructed with AISI 304 stainless steel sheet. Designed for inclusion of post-heating exchanger inside the unit.



Brushless motor (optional)



Ducted



Directly coupled fan

PLUS

- » Horizontal/vertical configuration
- » Plug-fan
- » Internal bypass damper
- » Plug-and-play product
- » Jonix sanitizing module
- » Easy maintenance

AVAILABLE VERSION

RPE - S

Standard version with polyurethane insulation

RPE - X

Extra comfort version with mineral wool insulation and thermal break profile



MAIN COMPONENTS

Structure

Closing panels made of a double sheet of galvanized steel, pre-painted on the outer surface, completely removable for inspection/maintenance, and with different inlet/outlet configurations;

Internal heat and sound insulation

Made from polyurethane foam (RPE-S δ 38 kg/m³) or mineral wool (RPE-X δ 80 kg/m³) with a thickness of 30 mm. Fire reaction A1 class.

Fans

Ventilation sections with directly coupled electric fans of AC type with potentiometer or EC plug-fan with 0-10 V C/C control.



Heat recovery

Upstream-flow heat recuperator, with aluminium frame, aluminium heat exchanger block with self-distanced fins and sealed at the ends in order to prevent contamination of the fresh air by the expelled air. Condensate collection and drainage container constructed with AISI 304 stainless steel sheet. Minimum heat efficiency 73%, complete with internal bypass damper;

Filter section

-Medium-efficiency filtering section on the room air intake Class M6 (EPM 10 80%; EN 16890)
- High-efficiency filtering section on the outside air intake Class F7 (EPM 1 50%; EN 16890)

Sanitizing module JONIX™



By-pass for free cooling

The heat recovery unit, inside the unit, includes the single-control dual damper for managing the bypass. The damper can be integrated with servo control (SSB) with on/off control signal. Free-cooling operation can be managed by the EVO SYSTEM control.

The JONIX™ sanitizing module is available on request: the controlled ionization devices are able to eliminate up to 99% of germs, viruses, and volatile organic compounds (in comparison to their initial concentration) without the production of ozone or toxic chemicals and with greatly reduced energy consumption. Ionizers promote the controlled formation of ionic particles (electrically charged particles) in the air, by means of an electric field that simulates normally occurring natural processes such as the solar radiation, atmospheric events, or other events. The ionic particles created have been historically and scientifically proven to be beneficial to humans, especially those with a negative charge (formed by atoms or molecules that receive an electron)

Sanitizing action on surface in contact with treated air



JONIX™ DUCT is a Class I medical device according to 93/42 CEE European Directive amended by 2007/47/EC and registered with the CND code Z12159099.

ACCESSORIES

Regulation	
TED	Electronic microprocessor control
EVO	Circuit board + remote control
CO₂ VOC	Probe CO ₂ + VOC (only with EVO control)
CPO / CPR	Control at constant air flow / Control at constant static pressure
Internal coils	
BREA	Electric pre-heating coil for outside air/antifreeze (including antifreeze thermostat)
BPRE	Electric post-heating coil
BPRA	Water heating coil without valve
External coils	
BPFA	Water cooling coil without valve
BFDX	Direct expansion cooling coil
Motorized valves	
V20	Two-way valve + on/off actuator ^{(1) (2)}
V30	Three-way valve + on/off actuator ^{(1) (2)}

V2M	Two-way valve + 0-10VDC modulating actuator ^{(1) (2) (3)}
V3M	Three-way valve + 0-10VDC modulating actuator ^{(1) (2) (3)}
SSB	On/off servo-control for bypass damper (only with EVO control)
Various accessories	
F9 / M6	F9 filter outlet and M6 intake
KP	Support feet for the horizontal version
TP	Protection canopy for outside installation
JONIX™	Sanitizing system module, complete with self-diagnostics ⁽²⁾

(1) Valve and actuator are supplied loose (installation not included)
(2) Power supply cannot be derived from EVO SYSTEM
(3) Fixed point temperature control probe

Heat recovery unit RPE

RATED TECHNICAL DATA

RPE			55	110	175	220	255	320	410	500	600
Air flow rate		m ³ /h	550	1000	1750	2200	2550	3200	4000	5000	6000
Available static pressure (max rpm) AC		Pa	180	150	130	100	200	150	370	300	200
Available static pressure (max rpm) EC		Pa	250	300	400	250	400	250	400	300	500
Sound power level (max rpm)	(1)	dB (A)	69	72	77	77	77	79	73	76	78
FILTRATION											
Intake			M6								
Outlet			F7								
HEAT RECOVERY UNIT											
Winter operation (balanced air flow)											
Wet efficiency		%	90,5	91,3	93,1	93,1	95,2	94,7	94,4	95	95,4
Dry efficiency (*)	(*)	%	79,1	82,2	83,5	83,4	85,3	84,4	83,9	84	84,3
Recovery		Kw	4,02	8,24	14,6	18,3	21,5	26,8	33,3	41,7	50,2
Outlet air temperature		°C	17,1	17,4	17,9	17,9	18,6	18,4	18,3	18,5	18,6
Summer operation (balanced air flow)											
Wet efficiency		%	74,5	76,8	77,3	78	78	78,9	78,4	78,5	78,8
Recovery		Kw	1,24	2,49	4,34	5,5	6,38	8,02	9,95	12,4	14,9
Outlet air temperature		°C	28,3	28,1	28	28	27,8	27,9	27,9	28	28
FANS											
Number of fans		n°	2								
Electrical input max AC		Kw	0,29	0,45	0,67	1,12	1,12	0,73	0,73	1,52	1,52
Electrical input max EC		Kw	0,17	0,17	0,50	0,78	0,78	0,78	1,35	2,50	3,90
Maximum total power consumption AC		A	1,28	1,97	2,92	5,40	5,40	3,21	3,21	2,91	2,91
Maximum total power consumption EC		A	1,75	1,75	2,5	4,00	4,00	3,90	4,50	6,10	6,50
Protection rating		IP	54								
Insulation class			F								
Power supply		V/ph/Hz	230/1/50	230/1/50	230/1/50	230/1/50	230/1/50	230/1/50	400/3/50	400/3/50	400/3/50

Winter condition

External air temperature -10°C B.S., U.R. 90%

Indoor recirculation temperature 20°C B.S., U.R. 50%

Summer condition

External air temperature 35°C B.S., U.R. 50%

Indoor recirculation temperature 26°C B.S., U.R. 60%

(1) Sound power in dB(A) in supply, nominal air flow

(*) Thermal efficiency in according with new directive European CE 1253/2014/CE «thermal efficiency of a not residential HRS = ratio between inlet air heat gain and outlet air thermal loss, both referred to external temperature, measured in dry conditions, with a balanced mass flow, and a thermal difference between indoor air / outside air of 20 K, taking not in account the heat gain generated by fan motors and internal leakage.

LAYOUT INPUT/OUTPUT

HORIZONTAL INSTALLATION

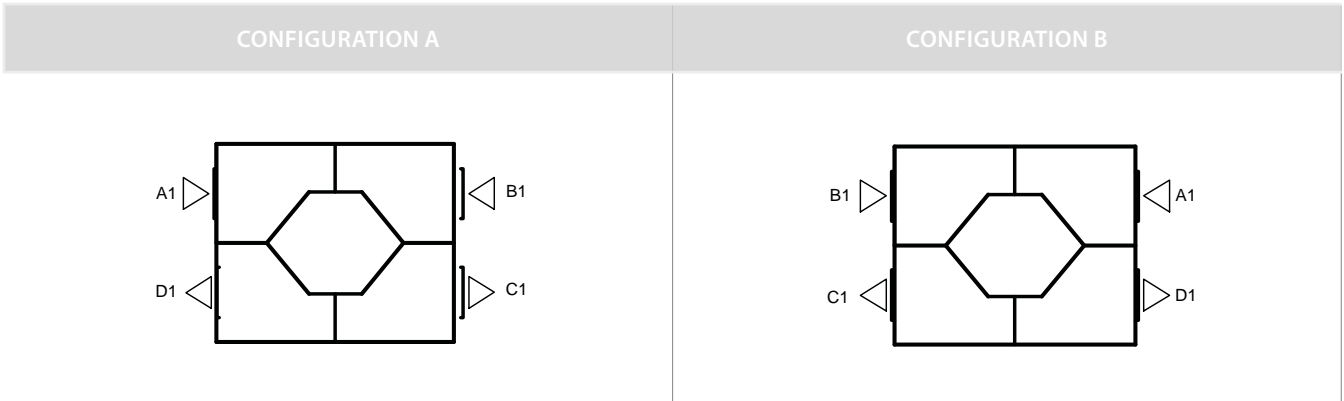

VERTICAL INSTALLATION

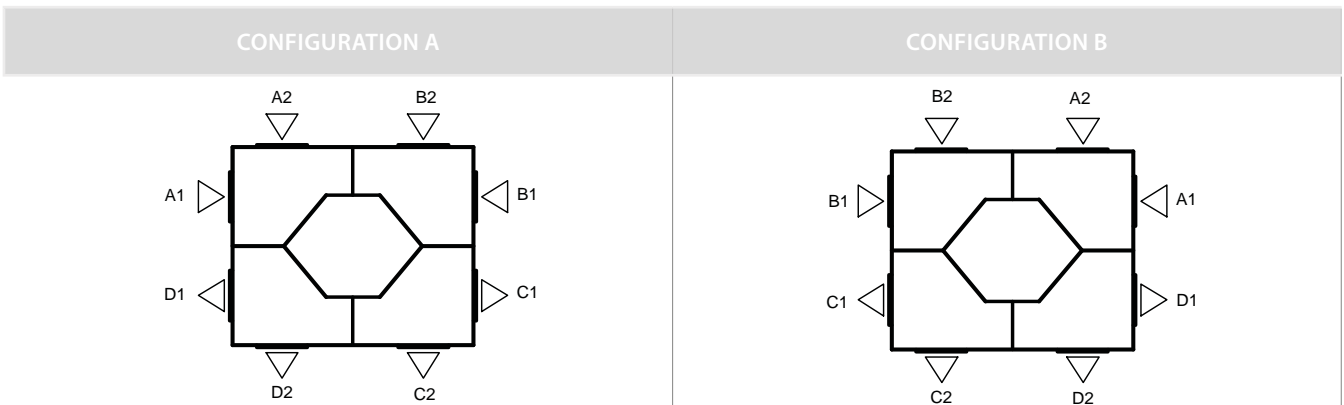

(C) Supply air
(B) Recirculation air

(A) Fresh air
(D) Exhaust air

WARNING:
55/110 models available only with horizontal configuration
410/500/600 models available only with vertical configuration

DIMENSIONAL DRAWINGS

RPE

RPE	55	110	175	220	255	320	410	500	600
H	295	360	520	520	660	660	-	-	-
P	965	1260	1705	1705	2000	2000	-	-	-
L	1585	2000	2300	2300	2600	2600	-	-	-
	115	185	225	300	440	440	-	-	-

RPE	55	110	175	220	255	320	410	500	600
P	-	-	520	520	660	660	800	800	950
H	-	-	1805	1805	2100	2100	2100	2100	2100
L	-	-	2300	2300	2600	2600	2750	2750	2900
	-	-	225	300	440	440	520	520	610

The dimensional data given herein are approximate.

As part of its commitment to improving products, Galletti S.p.A. reserves the right to introduce changes to technical and/or price list data without notice.

Due to printing, the colours of the products that appear in this document may differ from the actual colours.

All copying, even partial, of this document is strictly forbidden.



Galletti S.p.A.

Via L.Romagnoli, 12/a | 40010 Bentivoglio (BO) ITALY

T +39 051 8908111 | F +39 051 8908122/3

info@galletti.it | www.galletti.com

